

HOT SWAP CAPABILITY ELIMINATES DOWN TIME

Systems applications which employ fault tolerant power delivery architectures, usually require “Live Swap” capability for zero downtime. Modern telecommunications and data communications systems are examples where this requirement is generally imposed. The ability to live swap or hot swap, as it is sometimes called, has a significant impact on the power supply design. The scope of this technical note includes design considerations as related to 48 V distributed power architectures which employ hot swappable, modular power converters.

Hot swap capability imposes special needs to insure survival of the component which is subjected to live insertion and extraction. In addition, it is necessary to prevent any significant disturbance of either input or output power rails during live insertion / extraction. Any significant, even momentary perturbation of either bus could cause the system to malfunction. Individual contacts within a typical connector do not engage / disengage simultaneously, but rather in an undefined random sequence. It is therefore necessary to take steps to insure orderly power up / down.

The design rules which satisfy the above requirements can be summarized as follows;

1. Terminal constraints or absolute maximum ratings of components must never be violated, even momentarily during live insertion / extraction.
2. Inrush current during live insertion of a module must be limited to an acceptable level to prevent momentary interruption or sag of the input 48 V bus, and to minimize arcing between mating contacts.
3. Load takeover of the live inserted converter must be rate limited, smooth, and without sudden transition so as not to upset regulation of the output bus.
4. A converter module must never be allowed to transfer energy, i.e., produce power pulses while disengaged from the load, or while it's sense lines are unterminated.

NOTE: Sense resistor removed to prevent module drive / booster arbitration.

In order to satisfy these requirements, a small amount of additional circuitry on each hot pluggable module is necessary for protection and sequencing. This insures that during extraction, the converter is disabled prior to the load being disengaged or the sense lines unterminated, and that during live insertion, the converter is momentarily held in a disabled state until all input and output terminations are complete. The effects of random engagement / disengagement of connector contacts during insertion / extraction might otherwise cause damage to the module, or even system failure.

The first and foremost requirement for fault tolerance is redundancy, i.e., the existence of at least one extra, or “redundant” converter in the system. This is commonly referred to as an N+M array, where N converters are required to satisfy the power requirements, and M additional modules provide redundancy. All modules in the array must be capable of supplying undisturbed power in the event of shut down or failure of one module, in spite of the sudden increased load demanded of each. The same is true for the case where an additional module is placed on line, suddenly reducing the current demanded of each module. To satisfy these criteria, it's essential that the individual converters share the load current, in order to minimize the dynamic response or recovery required of each. Some means of current share control must be employed, and there is a second but equally important reason for load share control. Reliability is severely impacted by operating temperature. Mean time between failure numbers roughly double every 10 Celsius degrees decrease in operating temperature. A module delivering twice the load current of another in the array, will experience twice the temperature rise above ambient.

Vicor's Maxi, Mini, Micro Series converters boast a number of features which simplify application in a redundant parallel array.

The most significant of these include enable / disable capability, a unique master / slave current share control scheme, and the ability to self arbitrate the leadership role. One converter will always assume command of the entire array. These products also possess the commonly available features, such as undervoltage lockout, softstart, output current limiting, and remote sense capability. The Vicor converter topology is resonant zero current switched. Line and load regulation is accomplished by controlling the frequency or rate at which pulses of energy are transferred from the primary to the secondary of the isolation transformer. The pulse width, and therefore the energy per pulse is constant at any given input voltage. The repetition rate is controlled to satisfy the load current demand, while maintaining output voltage regulation. It follows therefore that identical converters will inherently share the load if the switching frequencies are synchronized.

The PR pin on Maxi, Mini, Micro Series converter modules is a bidirectional port which serves as a parallel load share bus. This port can transmit or receive the synchronizing pulse signal. The controlling module transmits the sync pulse and all other modules listen, as further described in the section entitled "Parallel Bus".

The PC (Primary Control) pin is also a bidirectional port. This port serves as a module status output, and normally is at 6 Vdc during operation of the converter. In the event of a fault condition, such as over temperature or over voltage at the output, PC switches to the low state (approximately 0 V with respect to the negative Vin pin when resistively terminated). PC periodically toggles high attempting to restart while the fault condition persists, but will remain high only when the fault condition is corrected.

PC also serves as an Enable / Disable input. The converter shuts down if PC is externally pulled low, and will source a pulsed approximately 2 mA while held in the low state. These characteristics facilitate the use of a transistor switch with uncommitted collector or drain for the Enable / Disable function.

The Sense pins are used to provide accurate voltage regulation across the output power bus at the terminus, usually the location of the system's load. The terminated Sense lines close the regulation control loop, which adjusts

the converter output voltage to compensate for voltage drops in the output power bus. Termination of the Sense pins is imperative in order to maintain output voltage control. Fault tolerant parallel arrays must employ auctioneering diodes in series with the output of each module to the power bus. The converter output currents are summed at the junction of all diodes on the bus. This insures the integrity of the bus and the system's operation in the event of a failure of any type, including output short circuit, in any one module. The diode is reversed biased and simply isolates the converter from the bus if its output voltage drops out. Each module's sense lines must be terminated beyond the diodes, and the hot swap connector at the common bus.

To summarize, a hot swappable plug-in module must possess the following features and characteristics.

1. Shut down prior to extraction.
2. Momentarily disabled start up upon insertion
3. Inrush current limiting

These requirements can be realized in a number of ways. The obvious, simplest way to keep a converter disabled during the trauma of live insertion or extraction is with a mechanical switch that can be placed in the Off position prior to insertion, then switched On once the connector contacts are firmly mated. Conversely, the switch can be placed in the Off position prior to extraction. The PC pin which conveniently lends itself to the Enable / Disable function, can be controlled by the switch. It is preferable that the hot swappable assembly includes locking tabs to secure it once inserted, the locking tabs should be mechanically linked to a microswitch to enable and disable the converter. Only after the board is fully inserted into the back plane.

An alternative approach automatically disables the converter during insertion and extraction, thus avoiding the need for manual intervention as with a mechanical switch. This eliminates the possibility of human error, i.e., plugging or unplugging while the switch is in the ON position. The method illustrated in Figure 1 accomplishes this but requires the use of a connector with staggered contacts. Specifically, this approach employs a single

Finally, the converter output voltage runs up to the point where the auctioneering diode is forward biased, at which point the module delivers it's equal share of the load.

The shut down sequence upon extraction is approximately the reverse of the above. The short pin disengages well in advance of all the other pins which immediately causes the IAM to turn off the 48 V. At the same time, the converter is disabled. The shunt switch in the IAM rapidly discharges (<50 ms) the bus capacitance, while C2 continues to provide current to hold Q3 on. This insures that the PC pin is held low, well beyond the point in time where the 48 V bus decays to the undervoltage lockout threshold. This, in turn, guarantees that the converter cannot process power conversion pulses during the random disengagement of all other contacts.

This technique has been employed successfully, and has demonstrated minimal perturbation of both input and output bus voltages during insertion and extraction, while insuring that maximum voltage ratings of all module pins are never violated. The short connector pin, while adding a minor degree of complexity, absolutely guarantees preparation for the random and hostile contact mating sequence during insertion, and likewise, preparation for the random disengagement sequence during extraction.

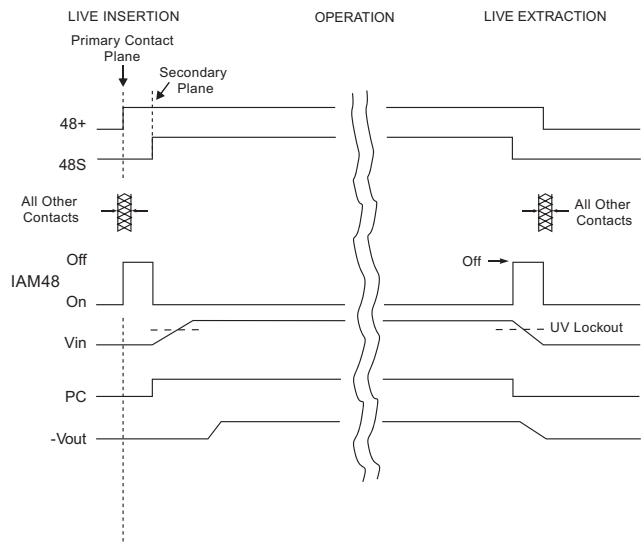

Figure 2 - Live Swap Timing Diagram