

**Safety Considerations**

**Fusing:** Safety agency conditions of acceptability require that the module positive (+) Input terminal be fused and the baseplate of the converter be connected to earth ground. The following table

lists the acceptable fuse types and current rating for the Maxi, Mini, Micro Family of DC-DC converters. Safety Certifications on the Vicor web site should always be consulted for the latest fusing requirements.

**Acceptable Fuse Types and Current Rating for the Maxi, Mini, Micro Family of Converters**

Package Size	Input Voltage (V)	Output Voltage (V)	Output Power (W)	Required Fuse
Maxi (A)	375	2	160	Bussmann PC-Tron 5A
Maxi (A)	375	3.3	264 / 200	Bussmann PC-Tron 5A
Maxi (A)	375	5, 8	400 / 300	Bussmann PC-Tron 5A
Maxi (A)	375	12, 15, 24, 28, 32, 36, 48, 54	600 / 400	Bussmann PC-Tron 5A
Mini (B)	375	2	100	Bussmann PC-Tron 5A
Mini (B)	375	3.3	150 / 100	Bussmann PC-Tron 5A
Mini (B)	375	5, 8	200 / 150	Bussmann PC-Tron 5A
Mini (B)	375	12, 15, 24, 28, 36, 48	300 / 200	Bussmann PC-Tron 5A
Micro (C)	375	2	50	Bussmann PC-Tron 3A
Micro (C)	375	3.3	75 / 50	Bussmann PC-Tron 3A
Micro (C)	375	5, 8	100 / 50	Bussmann PC-Tron 3A
Micro (C)	375	12, 15, 24, 28, 36, 48	150 / 75	Bussmann PC-Tron 3A
Maxi (A)	300	2	160	Bussmann PC-Tron 5A
Maxi (A)	300	3.3	264 / 200	Bussmann PC-Tron 5A
Maxi (A)	300	5, 8	400 / 300	Bussmann PC-Tron 5A
Maxi (A)	300	12, 15, 24, 28, 36, 48	500 / 400	Bussmann PC-Tron 5A
Mini (B)	300	2	100	Bussmann PC-Tron 5A
Mini (B)	300	3.3	150 / 100	Bussmann PC-Tron 5A
Mini (B)	300	5, 8	200 / 150	Bussmann PC-Tron 5A
Mini (B)	300	12, 15, 24, 28, 36, 48	250 / 150	Bussmann PC-Tron 5A
Micro (C)	300	2	50	Bussmann PC-Tron 3A
Micro (C)	300	3.3	75 / 50	Bussmann PC-Tron 3A
Micro (C)	300	5, 8	100 / 50	Bussmann PC-Tron 3A
Micro (C)	300	12, 15, 24, 28, 36, 48	150 / 75	Bussmann PC-Tron 3A
Maxi (A)	150	3.3	264 / 200	Bussmann ABC-8
Maxi (A)	150	5, 8	400 / 300	Bussmann ABC-8
Maxi (A)	150	12, 15, 24, 28, 36, 48	500 / 400	Bussmann ABC-8
Mini (B)	150	3.3	150 / 100	Bussmann PC-Tron 5A
Mini (B)	150	5, 8	200 / 150	Bussmann PC-Tron 5A
Mini (B)	150	12, 15, 24, 28, 36, 48	250 / 150	Bussmann PC-Tron 5A
Micro (C)	150	3.3	75	Bussmann PC-Tron 3A
Micro (C)	150	5, 8	100	Bussmann PC-Tron 3A
Micro (C)	150	12, 15, 24, 28, 36, 48	150	Bussmann PC-Tron 3A
Maxi (A)	110	3.3	200 / 150	Bussmann ABC-8
Maxi (A)	110	5, 8	300 / 200	Bussmann ABC-8
Maxi (A)	110	12, 15, 24, 28, 36, 48	400 / 300	Bussmann ABC-8
Mini (B)	110	3.3	100 / 75	Bussmann PC-Tron 5A
Mini (B)	110	5, 8	150 / 100	Bussmann PC-Tron 5A
Mini (B)	110	12, 15, 24, 28, 36, 48	200 / 150	Bussmann PC-Tron 5A
Micro (C)	110	3.3	50	Bussmann PC-Tron 3A
Micro (C)	110	5, 8	75	Bussmann PC-Tron 3A
Micro (C)	110	12, 15, 24, 28, 36, 48	100	Bussmann PC-Tron 3A

Acceptable Fuse Types and Current Rating for the Maxi, Mini, Micro Family of Converters (Cont.)				
Package Size	Input Voltage (V)	Output Voltage (V)	Output Power (W)	Required Fuse
Maxi (A)	72	3.3	264	Bussmann ABC-12
Maxi (A)	72	5, 8	300	Bussmann ABC-12
Maxi (A)	72	12, 15, 24, 28, 36, 48	400	Bussmann ABC-12
Mini (B)	72	3.3	100	Bussmann ABC-8
Mini (B)	72	5, 8	150	Bussmann ABC-8
Mini (B)	72	12, 15, 24, 28, 36, 48	250	Bussmann ABC-8
Micro (C)	72	3.3	75	Bussmann PC-Tron 5A
Micro (C)	72	5, 8	100	Bussmann PC-Tron 5A
Micro (C)	72	12, 15, 24, 28, 36, 48	150	Bussmann PC-Tron 5A
Maxi (A)	48	3.3	264	Bussmann ABC-10
Maxi (A)	48	5, 8	400	Bussmann ABC-15
Maxi (A)	48	12, 15, 24, 28, 36, 48	500	Bussmann ABC-20
Mini (B)	48	2	100	Bussmann ABC-8
Mini (B)	48	3.3	150	Bussmann ABC-8
Mini (B)	48	5, 8	200	Bussmann ABC-10
Mini (B)	48	12, 15, 24, 28, 36, 48	250	Bussmann ABC-10
Micro (C)	48	2	50	Bussmann PC-Tron 5A
Micro (C)	48	3.3	75 / 50	Bussmann PC-Tron 5A
Micro (C)	48	5, 8	100 / 75 / 50	Bussmann ABC-8
Micro (C)	48	12, 15, 24, 28, 36, 48	150 / 75	Bussmann ABC-8
Maxi (A)	28	3.3	150	Bussmann ABC-25
Maxi (A)	28	5	175	Bussmann ABC-25
Maxi (A)	28	6.5, 8, 12, 15, 24, 28, 36, 48	200	Bussmann ABC-30
Mini (B)	28	3.3	75	Bussmann ABC-15
Mini (B)	28	5	75	Bussmann ABC-15
Mini (B)	28	12, 15, 24, 28, 36, 48	150	Bussmann ABC-15
Micro (C)	28	3.3	50	Bussmann ABC- 8
Micro (C)	28	5	50	Bussmann ABC-10
Micro (C)	28	12, 15, 24, 28, 36, 48	100	Bussmann ABC-10
Maxi (A)	24	3.3	264 / 200	Bussmann ABC-25
Maxi (A)	24	5, 8, 12, 15, 24, 28, 36, 48	400 / 300	Bussmann ABC-30
Mini (B)	24	3.3	150 / 100	Bussmann ABC-15
Mini (B)	24	5, 8, 12, 15, 24, 28, 36, 48	200 / 150	Bussmann ABC-15
Micro (C)	24	3.3	75 / 50	Bussmann ABC-8
Micro (C)	24	5, 8, 12, 15, 24, 28, 36, 48	100 / 50	Bussmann ABC-10

The fuse must be in series with the positive (+) Input lead. Fusing the negative (-) Input lead does not provide adequate protection since the PR and PC terminals of the converter are referenced to the -Input. If a fuse located in the -Input lead were to open, the PR and PC terminals could rise to the potential of the +Input. This may damage any converter or circuitry connected to these pins. The fuse should not be located in an area with a high ambient temperature as this will lower the current rating of the fuse.

### Thermal and Voltage Hazards

Vicor component power products are intended to be used within protective enclosures. Vicor DC-DC converters work effectively at baseplate temperatures, which could be harmful if contacted directly. Voltages and high currents (energy hazard) present at the terminals and circuitry connected to them may pose a safety hazard if contacted or if stray current paths develop. Systems with removable circuit cards or covers which may expose the converter(s) or circuitry connected to the converters, should have proper guarding to avoid hazardous conditions.

The module pins are intended for PCB mounting either by wave soldering to a PCB or by insertion into one of the recommended PCB socket solutions. Use of discrete wire soldered directly to the pins may cause intermittent or permanent damage to the module; therefore, it is not recommended as a reliable interconnection scheme for production as a final released product. In addition, modules that have been soldered into printed circuit boards and have subsequently been removed should not be reused.

### PC Pin

The PC pin should be used only to disable the module, provide a bias to input referenced circuitry or communicate status of the module. The PC pin is referenced to the -Input pin. All circuits that connect to the PC pin must use the -Input as the reference. Do not break the connection between the -Input and the circuitry connected to the PC pin or damage to the module will result. Additional requirements include:

- Circuits that derive their power from the PC pin must not exceed 1.5mA.
- Do not drive the PC pin with external circuitry.
- Do not attempt to control the output of the converter by PWM pulsing of the PC pin, or exceed a repetitive on / off rate of 1Hz.

For applications where the converter will be disabled on a regular basis or where capacitance is added to this pin, please contact Vicor Applications Engineering.

### High-Power Arrays and PR Pin

To simplify the implementation of large arrays, a subset of modules within the parallel array should be configured as boosters (listeners) by connecting the SC pin to the -S pin. Modules, which are configured as boosters, cannot assume the role of drivers (talkers) for N+M redundant arrays. Modules configured as boosters may be locally sensed.

Each module within the parallel array must be properly bypassed with capacitors. Film or ceramic types should be used across the input of the module and between each input lead and the baseplate. Modules having input sources, which are not connected to SELV sources, should use X-capacitors across the input and Y-capacitors from each input power pin to the baseplate. When in doubt about capacitor safety approvals, always consult with the governing safety regulatory agency or Vicor Applications Engineering.

A maximum of 12 modules may be directly connected in parallel. Please contact Vicor Applications Engineering for assistance with larger arrays.

The PR pin is referenced to the -IN pin; therefore, all modules within the array must have a common low-impedance connection between each -IN pin. Special precautions are necessary if a PCB is not used for interconnection of modules, because the wiring impedance can be significant. Do not allow the connection between the -IN pin and the -IN bus to become disconnected as damage to the module will result.

Coupling transformers should be used to transmit the PR pulse if long distances between each module are anticipated or if the interconnection impedance of the -IN leads is high or questionable. PR coupling transformer(s) should be used if the PR pulse exits the PCB. For example, an array constructed of multiple circuit cards plugged into a backplane with a number of converters on each card should have a PR coupling transformer at the entry point of each card; however, no coupling transformer would be required between each converter on the card of three or less converters on a single PCB. Do not externally drive the PR pin, connection to this pin is limited to Vicor module application only.

### Input Source Impedance

The impedance of the source feeding the input of the module directly affects both the stability and transient response of the module. In general, the source impedance should be lower than the input impedance of the module by a factor of ten, from DC to 50kHz.

To calculate the required source impedance, use the following formula:

$$Z = 0.1(V_{LL})^2 / P_{IN}$$

where:

- Z is required input impedance
- $V_{LL}$  is the low line input voltage
- $P_{IN}$  is the input power of the module

Filters, which precede the module, should be well damped to prevent ringing when the input voltage is applied or the load on the output of the module is abruptly changed.

### Input Transients and Surges

The voltage applied to the input of the module must not exceed the ratings outlined in the data sheet. Protection devices such as Zener diodes and MOVs should be used to protect the module from short-duration transients. These shunt protection devices are effective only if the source impedance is high relative to the impedance of the protection device when it is conducting. For voltage surges where the abnormal voltage is present for a long period of time, shunt protection devices can easily be damaged by the power dissipated. For this type of condition, a voltage limiter in series with the input of the module may be the best solution. Vicor Applications Engineering can assist in recommending the appropriate type of protection for the module.

**NOTE:** Do not allow the rate of change of the input voltage to exceed 10V $\mu$ s for any input voltage deviation. To prevent damage, allow a minimum of 1s between power on / off / on cycles to allow for the reinitialization of converter soft start.

### Sense Leads (Mini and Maxi only)

The sense leads of the module must always terminate either directly to the output pins (local sense) or at the load (remote sense). When remote sense is used, the output wiring impedance in combination with the load impedance can cause significant loss of phase margin and result in oscillation and possible damage to the module, poor transient response, or activation of the output overvoltage protection. Long sense leads may require a compensation circuit for stability.

Protection circuitry is required if the possibility of reversed sense leads can occur. Please contact Vicor Applications Engineering for specific recommendations.

Do **not** exceed 1V between –S and –OUT leads. This is an important consideration if the converter is used in a Hot-Swap application. ORing diodes, if used, should be located in the +Output lead to avoid exceeding this rating.

Do **not** exceed the rated power of the converter. The total of the power consumed by the load plus the power lost in conductors from the converter to the load must be less than the output power rating of the converter.

### Output Connections

For systems designed to charge batteries, subject the module output to dynamic loading or loads that have large reactive components, please contact Vicor Applications Engineering to discuss your application in detail.

Do **not** externally drive the output of the module 10% above its nominal setpoint voltage.

Modules that are used to charge batteries should be applied with a diode in series with the output of the module. The charge current must be externally controlled to ensure that the module is not operated in excess of its power or current rating.

Current-carrying conductors should be sized to minimize voltage drops.

Do **not** use output ORing diodes with parallel arrays of the Micro Family converters.

**Output Overvoltage Protection (OVP):** The OVP detection circuitry within the converter is highly resistant to false tripping. For the converter to shut down due to an OVP condition two conditions must be satisfied (logical AND):

1. The voltage at the output terminals must be greater than the OVP set point.
2. The secondary control IC within the converter must be requesting a power-conversion cycle from the internal primary control IC.

By using this logic, false tripping of individual converters due to externally induced OVP conditions such as load dumps or, being driven by external voltage sources at the output terminals is minimized. The user should not test the OVP circuit by back driving the output terminals or by any other means as the OVP circuitry is fully tested as part of the inline manufacturing process.

### Overcurrent Protection

The Maxi, Mini, Micro converters incorporate a straight-line type current limit. (Figure 3.1) As output current is increased beyond  $I_{max}$ , the output voltage remains constant and within its specified limits up to a point,  $I_{KNEE}$ , which is typically 5 – 25% greater than rated current,  $I_{max}$ . Beyond  $I_{KNEE}$ , the output voltage falls to  $I_{shortcircuit}$ . Typically, modules will automatically recover after the overcurrent condition is removed.

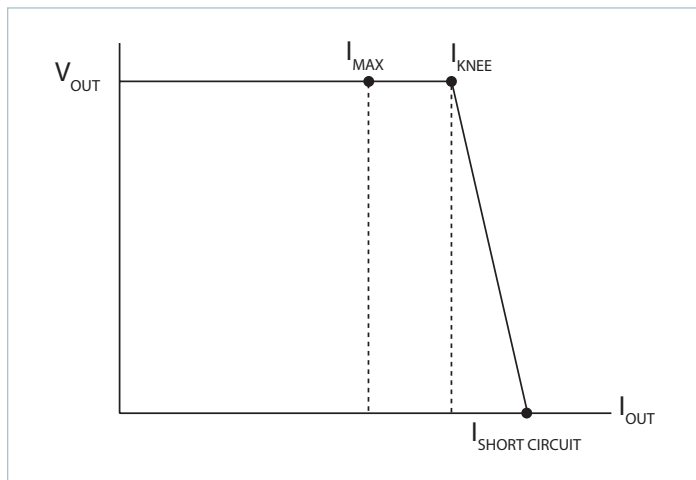

Figure 3.1 — Typical Maxi, Mini, Micro current limiting

### Maximum Output Capacitance

In general, adding external capacitance to the Maxi, Mini, and Micro's output is not required. However, it is often common practice with power supply designs to add external capacitance to the converter output for attenuation of output ripple and / or improving dynamic load performance. The Maxi, Mini, Micro converters typically have a faster response to dynamic loads than other power solutions; hence, external capacitors may not be necessary. In addition, the output ripple and noise specification listed on the data sheet may be acceptable for many applications.

A general equation for determining the maximum recommended output capacitance is as follows:

$$C_{\text{FARAD}} = \frac{\frac{P_{\text{OUT}}}{V_{\text{OUT}}} (400 \cdot 10^{-6})}{V_{\text{OUT}}}$$

where:

$P_{\text{OUT}}$  is the output power of the converter

$V_{\text{OUT}}$  is the nominal output voltage of the converter

The capacitance value is not the absolute maximum value, but the value for which general application of the converter can be deemed appropriate. Testing will be required to ensure that the module is stable if the maximum capacitance value is used. 10% of the modules available output current will be used to initially charge the capacitor. Therefore, a resistive load should utilize no greater than 90% of the rated current.

**Caution:** If exceeding this value, it is recommended that Vicor Applications Engineering be consulted.

### Absolute Maximum Ratings

Please consult the latest module data sheets available on the Vicor website for maximum ratings concerning pin-to-pin voltages, isolation, temperature, and mechanical ratings.

### Grounding of Baseplate and Referencing of Input and Output Terminals

The baseplate of the converter should always be connected to earth ground. If for any reason this is not possible in your application please consult with Vicor Applications Engineering for acceptable alternatives for your application.

The input and output leads of the converter should be referenced to the baseplate at some point to avoid stray voltages. For offline applications the input leads are often referenced to earth ground at the AC source ahead of the bridge rectifier. Either + or -Output terminal may be referenced to earth ground and the baseplate. "Floating" inputs or outputs should at a minimum have a high-resistance divider to bleed off stray charges to avoid damage to the insulation system.

### High-Frequency Bypassing

All Vicor converters must be bypassed for proper operation. (Figure 3.2) The minimum complement of high-frequency bypass capacitors must consist of the following:

- 0.2 $\mu$ F ceramic or film type connected between +IN and -IN.
- 4.7nF Y-capacitor between +IN and baseplate and -IN and baseplate.
- 10nF ceramic or film capacitor between +OUT and baseplate and -OUT and baseplate.

All applications utilizing Maxi, Mini, Micro converters should be properly bypassed, even if no EMC standards need to be met. Bypass  $V_{\text{IN}}$  and  $V_{\text{OUT}}$  pins to each module baseplate as shown in Figure 3.2. Lead length should be as short as possible. Recommended values vary depending on the front end, if any, that is used with the modules, and are indicated on the appropriate data sheet or application note. In most applications, C1 is a 4,700pF Y-capacitor (Vicor P/N 01000) carrying the appropriate safety agency approval; C2 is a 4,700pF Y-capacitor (Vicor P/N 01000) or a 0.01 $\mu$ F ceramic capacitor rated at 500V. In PC board applications, each of these components is typically small enough to fit under the module baseplate flange. For PCB mounting of the module. Please refer to Figures 3.3 and 3.4.

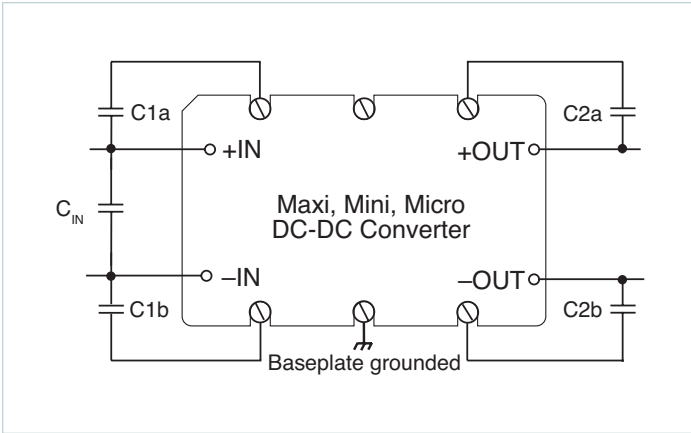

**Figure 3.2** — Minimum recommended bypassing for Maxi, Mini, and Micro; Keep all leads short

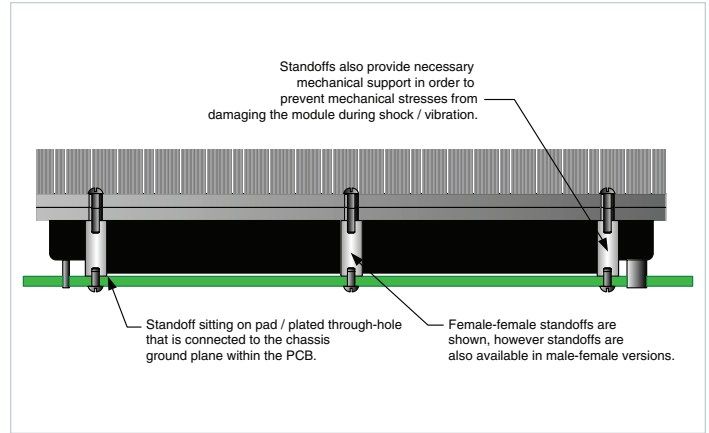

**Figure 3.3** — Recommended mounting method using standoffs

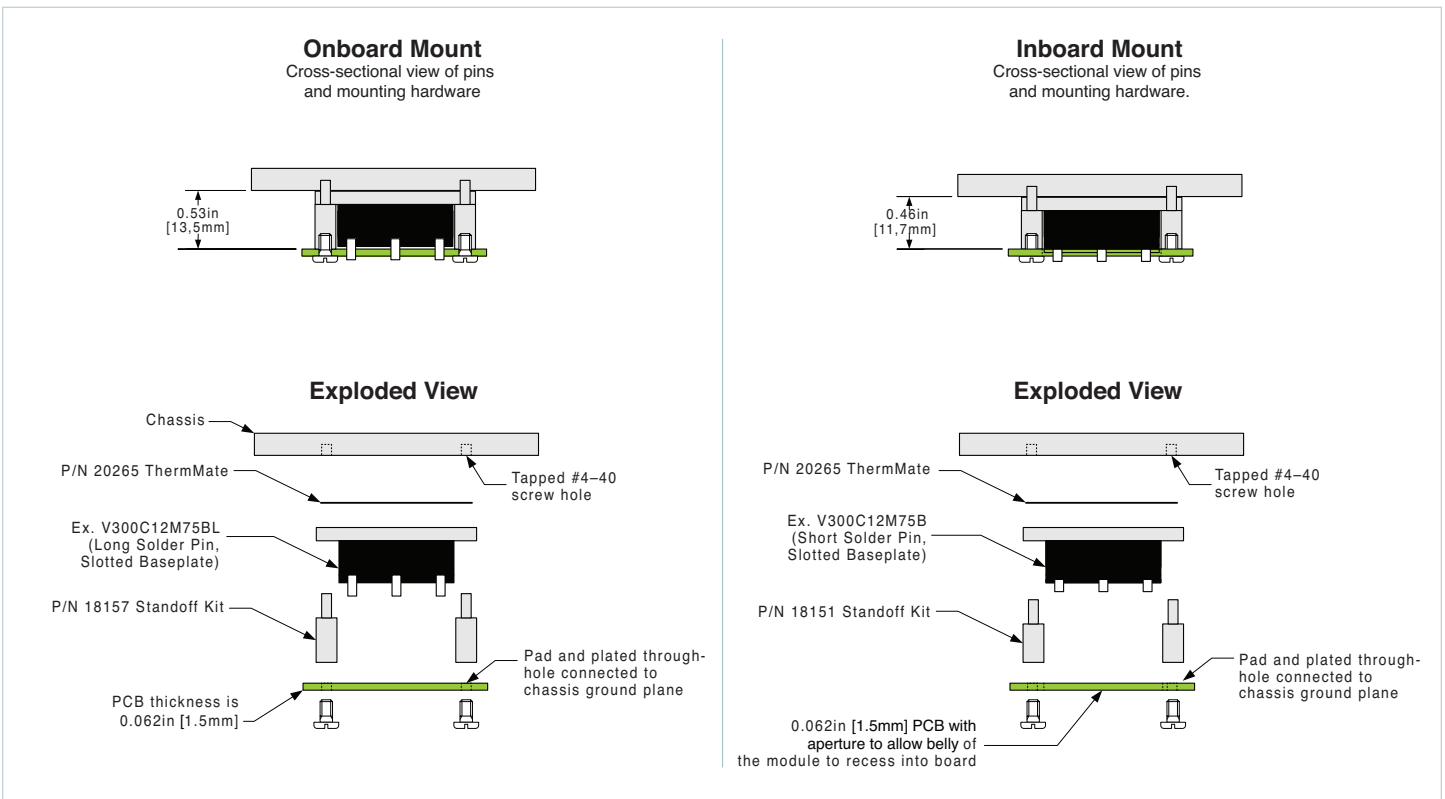

**Figure 3.4** — Onboard vs. inboard mounting of (1/4 brick) Micro with slotted baseplate

**Filtering and Transient Protection**

All switching power supplies generate potentially interfering signals as a result of high-frequency, high-power switching. The Vicor power converter topology, to a large extent, addresses the problem at the source by the use of a quasi-resonant, zero-current switching (ZCS) and zero-voltage switching (ZVS) topology. The switching current waveform is a half sine wave that generates far less conducted and radiated noise in both frequency spectrum and magnitude. EMI filtering, if properly designed and implemented, reduce the magnitude of conducted noise an additional 40 – 60dB, and as a result, the noise radiated by the power conductors is reduced proportionally.

Conducted noise on the input power lines can occur as either differential-mode or common-mode noise currents. Differential-mode noise, largely at low frequencies, appears across the input conductors at the fundamental switching frequency and its harmonics. Common-mode noise, which has mostly high-frequency content, is measured between the converter’s input conductors and ground.

The Vicor power converter being an electronic device may be susceptible to high levels of conducted or radiated emissions. It is the responsibility of the user to assess testing protocols in order to determine applicability of the converter in the intended application.