

ELECTRICAL CONSIDERATIONS GATE IN AND GATE OUT PINS

Logic Disable. When power is applied to the input pins, the GATE IN pin of a Driver can be pulled low with respect to the –IN thus turning off the output while power is still applied to the input. (Figure 7–1)

CAUTION: With offline applications –IN is not earth ground.

In Logic Disable mode, the GATE IN pin should be driven from either an “open collector” or electromechanical switch that can sink 6 mA when on (GATE IN voltage less than 0.65 V). If driven from an electromechanical switch or relay, a 1 µF capacitor should be connected from GATE IN to –IN to eliminate the effects of switch “bounce”. The 1 µF capacitor may be required in all applications to provide a “soft start” if the unit is disabled and enabled quickly. The GATE IN is not intended for repetitive on /off/on operation not exceeding once per second.

High Power Arrays. The pulsed signal at the GATE OUT pin of a regulating Driver module is used to synchronously drive the GATE IN pin of a companion Booster module to effect power sharing between the Driver and the Booster. (Figure 7–5) Daisy-chaining additional Boosters (i.e., connecting GATE OUT to GATE IN of a succeeding unit) leads to a virtually unlimited power expansion capability. VI-/MI-200 series modules of the same family and power level can be paralleled (i.e., Driver, VI-260-CU with Booster, VI-B60-CU).

In general:

- Don't drive the GATE IN pin from an “analog” voltage source.
- Don't leave GATE IN pins of Booster modules unterminated.
- Don't overload GATE OUT; limit load to a single Vicor module GATE IN connection, or 1 kΩ, minimum, in parallel with 100 pF, maximum.
- Don't skimp on traces that interconnect module –IN pins in high power arrays. GATE IN and GATE OUT are referenced to –IN; heavy, properly laid out traces will minimize parasitic impedances that could interfere with proper operation.
- Do use a decoupling capacitor across each module's input (see Input Source Impedance that follows).
- Do use an EMI suppression capacitor from +/– input and output pins to the baseplate.
- Do use a fuse on each module's + input to prevent fire in the event of module failure. See safety agency conditions of acceptability for the latest information on fusing. See link below:

http://www.vicorpower.com/technical_library/technical_documentation/quality_and_certification/safety_approvals/

Input Source Impedance. The converter should be connected to an input source that exhibits low AC impedance. A small electrolytic capacitor should be mounted close to the module's input pins. (C3, Figure 3–1) This will restore low AC impedance, while avoiding the potential resonance associated with “high-Q” film capacitors. The minimum value of the capacitor, in microfarads, should be $C (\mu\text{F}) = 400 \div V_{\text{in}}$ minimum. Example: V_{in} , minimum, for a VI-260-CV is 200 V. The minimum capacitance would be $400 \div 200 = 2 \mu\text{F}$. For applications involving long input lines or high inductance, additional capacitance will be required.

The impedance of the source feeding the input of the module directly affects both the stability and transient response of the module. In general, the source impedance should be lower than the input impedance of the module by a factor of ten, from DC to 50 kHz.

To calculate the required source impedance, use the following formula:

$$Z = 0.1(V_{\text{LL}})^2 / P_{\text{in}}$$

where: Z is required input impedance
 V_{LL} is the low line input voltage
 P_{in} is the input power of the module

Filters, which precede the module, should be well damped to prevent ringing when the input voltage is applied or the load on the output of the module is abruptly changed.

Input Transients. Don't exceed the transient input voltage rating of the converter. Input Attenuator Modules or surge suppressors in combination with appropriate filtering, should be used in offline applications or in applications where source transients may be induced by load changes, blown fuses, etc. For applications where the input voltage may go below low line it is recommended that an undervoltage lockout circuit be used to pull GATE IN low to disable the converter module. The undervoltage lockout circuit should induce a delay of at least one second before restarting the converter module. Longer delays will be required if external capacitance is added at the output to insure the internal soft-start is re-initialized.

NOTE: Do not allow the rate of change of the input voltage to exceed 10 V/µs for any input voltage deviation.

The level of transient suppression required will depend on the severity of the transients. A Zener diode, TRANSZORB™ or MOV will provide suppression of transients under 100 µs and act as a voltage clipper for DC input transients. It may be necessary to incorporate an LC filter for larger energy transients. This LC filter will integrate the transient energy while the Zener clips the peak voltages. The Q of this filter should be kept low to avoid potential resonance problems. See Section 14, Input Attenuator Module (IAM/MI-IAM) for additional information on transient suppression.

Output OVP. The VI-/MI-200, with the exception of VI-/MI-J00s, has an internal overvoltage protection circuit that monitors the voltage across the output power pins. It is designed to latch the converter off at 115 – 135% of rated output voltage. It is not a crowbar circuit, and if a module is trimmed above 110% of rated output voltage, OVP may be activated. Do not backdrive the output of the converter module to test the OVP circuit.

CAUTION: When trimming up VI-/MI-J00 modules, additional care should be taken as an improper component selection could result in module failure. Improper connection of the sense leads on VI-/MI-J00 modules can also result in an excessive overvoltage condition and module failure.

Input Reverse Voltage Protection. The module may be protected against reverse input voltages by the addition of a diode in series with the positive input, or a reverse shunt diode with a fuse in series with the positive input. See [Section 14](#), the Input Attenuator Module (IAM/MI-IAM) provides input reverse voltage protection when used with a current limiting device (fuse).

THERMAL / MECHANICAL CONSIDERATIONS

Baseplate. Operating temperature of the baseplate, as measured at the center mounting slot on the –IN, –OUT side, can not exceed rated maximum. ThermMate or thermal compound should be used when mounting the module baseplate to a chassis or heat sink. All six mounting holes should be used. Number six (#6) machine screws should be torqued to 5-7 in-lbs, and use of Belville washers is recommended.

The module pins are intended for PCB mounting either by wave soldering to a PCB or by insertion into one of the recommended PCB socket solutions.

CAUTION: Use of discrete wires soldered directly to the pins may cause intermittent or permanent damage to the module; therefore, it is not recommended as a reliable interconnection scheme for production as a final released product. See [Section 21](#) for packaging options designed for discrete wire connections (BusMod, MegaMod).

In addition, modules that have been soldered into printed circuit boards and have subsequently been removed should not be reused.

THERMAL AND VOLTAGE HAZARDS

Vicor component power products are intended to be used within protective enclosures. Vicor DC-DC converters work effectively at baseplate temperatures, which could be harmful if contacted directly. Voltages and high currents (energy hazard) present at the pins and circuitry connected to them may pose a safety hazard if contacted or if stray current paths develop. Systems with removable circuit cards or covers which may expose the converter(s) or circuitry connected to the converters, should have proper guarding to avoid hazardous conditions.

EMC CONSIDERATIONS

All applications utilizing DC-DC converters must be properly bypassed, even if no EMC standards need to be met. Bypass IN and OUT pins to each module baseplate as shown in Figure 3–1. Lead length should be as short as possible. Recommended values vary depending on the front end, if any, that is used with the modules, and are indicated on the appropriate data sheet. In most applications, C1a – C1b is a 4,700 pF Y-capacitor (Vicor Part # 01000) carrying the appropriate safety agency approval; C2a – C2b is a 4,700 pF Y-capacitor (Vicor Part # 01000) or a 0.01 μ F ceramic capacitor rated at 500 V. In PCB mount applications, each of these components is typically small enough to fit under the module baseplate flange.

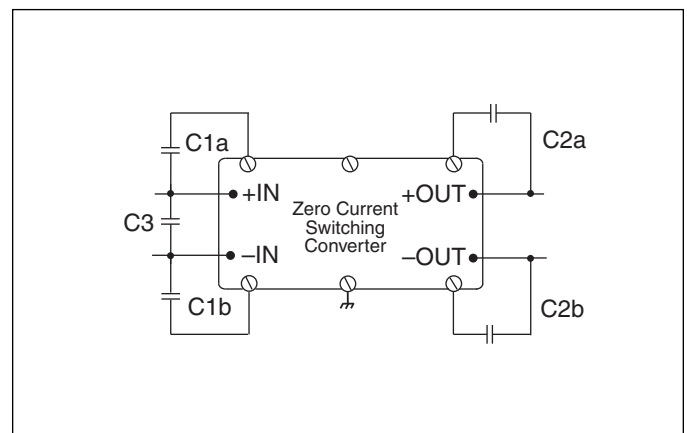

Figure 3–1 — IN and OUT pins bypassed to the module baseplate and input cap for low AC impedance

SAFETY CONSIDERATIONS

Shock Hazard. Agency compliance requires that the baseplate be grounded.

Fusing. Internal fusing is not provided in Vicor DC-DC converters. To meet safety agency conditions, a fuse is required. This fuse should be placed in the positive input lead, not the negative input lead, as opening of the negative input lead will cause the GATE IN and GATE OUT to rise to the potential of the +IN lead, causing possible damage to other modules or circuits that share common GATE IN or GATE OUT connections.

Safety agency conditions of acceptability require module input fusing. The VI-x7x, VI-x6x and VI-x5x require the use of a Buss PC-Tron fuse, or other DC-rated fuse. See below for suggested fuse ratings.

The safety approvals section of the Vicor website should always be checked for the latest fusing and conditions of acceptability information for all DC-DC converters including the MegaMod family. See link below:

http://www.vicorpower.com/technical_library/technical_documentation/quality_and_certification/safety_approvals/

Acceptable Fuse Types and Current Rating for the VI-200 and VI-J00 Family of Converters

Package Size	Required Fuse	Package Size	Required Fuse
VI-27x-xx	PC-Tron 2.5 A	VI-J7x-xx	PC-Tron 2.5 A
VI-26x-xx	PC-Tron 3 A	VI-J6x-xx	PC-Tron 3 A
VI-25x-xx	PC-Tron 5 A	VI-J5x-xx	PC-Tron 5 A
VI-2Tx-xx	PC-Tron 5A	VI-JTx-xx	PC-Tron 5A
VI-24x-xx	6 A / 125 V	VI-J4x-xx	PC-Tron 5A
VI-2Nx-xx	8A / 125 V	VI-JNx-xx	PC-Tron 5A
VI-23x-xx	8 A /125 V	VI-J3x-xx	PC-Tron 5A
VI-22x-xx	8 A / 60 V	VI-J2x-xx	PC-Tron 5A
VI-2Wx-xx	12 A / 50 V	VI-JWx-xx	8 A / 60 V
VI-21x-xx	12 A / 32 V	VI-J1x-xx	8 A / 60 V
VI-2Vx-xx	12 A / 32 V	VI-J0x-xx	8 A / 60 V
VI-20x-xx	12 A / 32 V		