

OVERVIEW

A number of GATE IN pins may be connected for remote shut down and logic disable. (Figure 6-1) Diodes D1 and D2 provide isolation and prevent multiple failures if the GATE IN of a module becomes shorted to the +IN. The Zener diodes Z1, Z2 and capacitors C1, C2 attenuate transient voltage spikes caused by differential inductance in the negative lead. Capacitors C1 and C2 will also

lengthen turn-on time. SW1 is a mechanical or solid state switch that is used to disable both Driver modules. C3 is used to minimize the effects of “switch bounce” associated with mechanical devices.

NOTE: GATE IN voltage needs to be <0.65 V referenced to -IN to ensure modules are disabled.

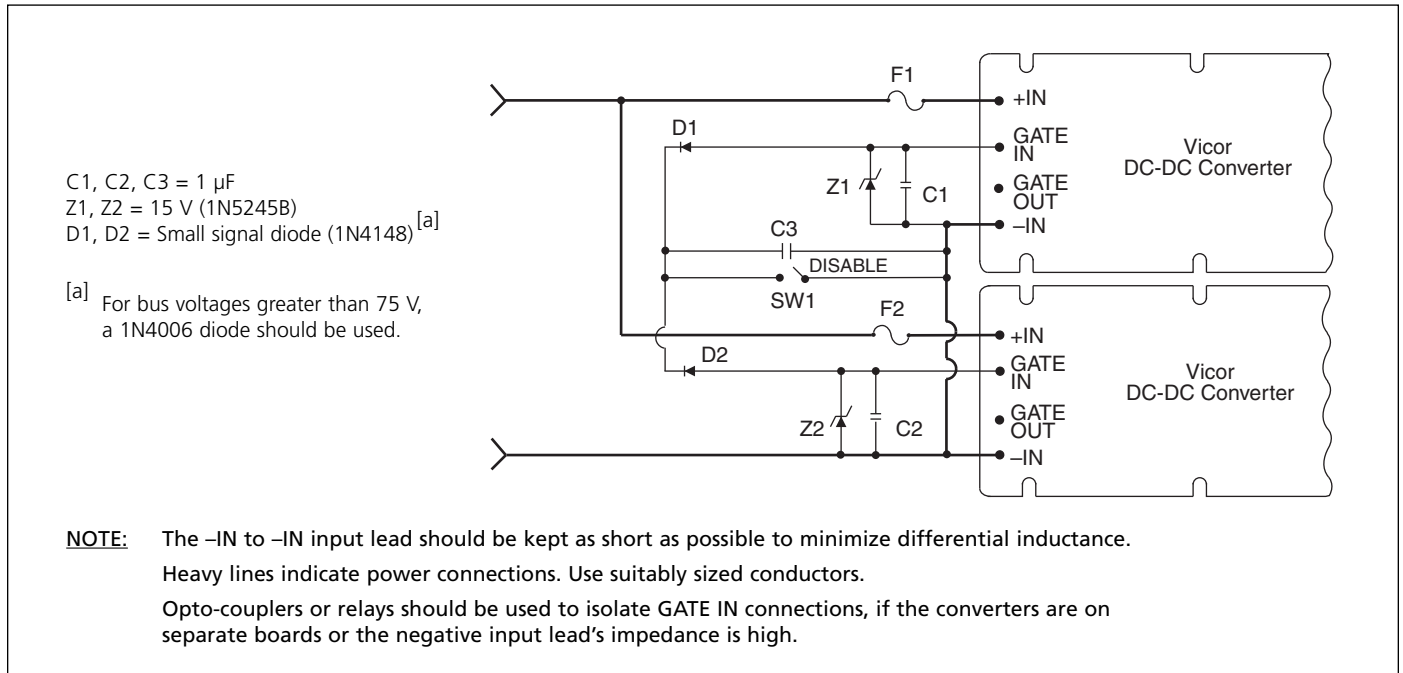

Figure 6-1 — Protection for multiple GATE IN connections