

REVISION			
REV	DESCRIPTION	DATE	APPROVED
X1	PRELIMINARY RELEASE	03-11-14	R. MILLER
X2	ADD CHARTS	--	----
X3	CHANGE CHARTS		

NOTES:

- MECHANICAL REQUIREMENTS: (SEE OUTLINE DRAWING).
EXTERIOR SHEET METAL MATERIAL: .090 THK AL ALY, 5052- H32 OR EQUIV.
FINISHES:
ALUMINUM: GOLD FILM PER MIL-C-5541, CLASS 1A.
COPPER: TIN PLATE.
BRASS: TIN OR NICKEL
PRINTED CIRCUIT DESIGN: PER IPC-275.
MATERIAL: FR4, 4 OZ CU ON OUTER LAYERS 2 OZ ON INNER LAYERS, 94-V-0. MIN.
COOLING REQUIREMENTS: FORCED-AIR COOLED WITH INTERNAL FAN.
- UNIT MOUNTED IN LOCATIONS MARKED "M", QTY=8. MARKING SHOWN FOR CLARITY ONLY, NOT ON SCREEN PRINT. UNIT MOUNTS USING 8-32 UNC-2B WITH .210 MAX. INSERTION DEPTH.
- CONNECTIONS:
AC INPUT: J1
POSITRONIC, D-SUB COMBO, 3W3, PLUG, PART NO. CBD3W3M55R80T0 3 POS., 15 AMP POWER CONTACTS WITH 4-40 THREADED JACKSCREWS.
MATES WITH POSITRONIC, D-SUB COMBO, 3W3, RECEPTACLE, PART NO. CBD3W3F00000 OR EQUIVALENT.

1	2
SINGLE PHASE	DC
J1-1 L1	J1-1 +
J1-2 L2/N	J1-2 -
J1-3 EARTH GND	J1-3 EARTH GND

STATUS/CONTROL CONNECTOR: J2

POSITRONIC, D-SUB, RECEPTACLE, 9 POS., PART NO. MD9F5R7NT20 WITH 4-40 THREADED JACKSCREWS. MATES WITH ITT/CANNON, D-SUB, PLUG, 9 POS., PART NO. DE9PK87 OR EQUIVALENT.

- J2-1 SPARE
- J2-2 SIGNAL RTN
- J2-3 FAN POWER
- J2-4 SIGNAL RTN
- J2-5 VCC +5V @ 300mA
- J2-6 AC POWER OK
- J2-7 PS ENABLE
- J2-8 PS INHIBIT
- J2-9 SPARE

OUTPUT TERMINATION

5/16-18 STUD WITH FLARE NUT.

- T1 +OUTPUT
- T2 -OUTPUT

DCOK CONNECTOR: J3

AMP, D-SUB CONN, 9-PIN, PLUG, PART NO. 7747043-4. MATES WITH ITT/CANNON, D-SUB, RECPT, 9-PIN, PART NO. DE9FK87 OR EQUIVALENT.

- J3-1 + SENSE
- J3-2 DCOK'
- J3-3 +5V VCC
- J3-4 PR2
- J3-5 CHASSIS GND
- J3-6 -SENSE
- J3-7 +5V VCC RTN
- J3-8 DCOK
- J3-9 PR1

- ELECTRICAL SPECIFICATIONS: (TYPICAL AT 25°C, NOMINAL LINE AND 75% LOAD, UNLESS OTHERWISE SPECIFIED)

INPUT REQUIREMENTS: (SEE FIGURE 1 AND 2.)

INPUT VOLTAGE: 85-254 VAC, 47-500Hz/100-380 VDC
INRUSH CURRENT: 30A RMS. MAX. @ 115 VAC/60A RMS. MAX. @ 230 VAC
RIDE-THROUGH TIME: 20 MS AT 1200W LOAD
POWER FACTOR: .99 (115 VAC 800W LOAD)/.95 (230 VAC 1200W LOAD)
TRANSIENT SURGE (COMMON MODE & NORMAL MODE): IEC 801-5 LEVEL 3
EFFICIENCY: TYPICALLY >75%

INPUT RATING CHARTS

FIGURE 1.

INPUT RATING	POWER MAXIMUM (WATTS)	INPUT TYPE (#)	INPUT VOLTAGE RANGE
1	600	(1) SINGLE PHASE (2) DIRECT CURRENT	80 / 85 TO 254 VAC 80 / 85 TO 380 VDC
2	800	(1) SINGLE PHASE (2) DIRECT CURRENT	102 / 108 TO 254 VAC 102 / 108 TO 380 VDC
3	1200	(1) SINGLE PHASE (2) DIRECT CURRENT	146 / 158 TO 254 VAC 146 / 158 TO 380 VDC
4	1600	(1) SINGLE PHASE (2) DIRECT CURRENT	192 TO 254 VAC 192 TO 380 VDC
5	1800	(1) SINGLE PHASE (2) DIRECT CURRENT	215 TO 254 VAC 215 TO 380 VDC

FIGURE 2.

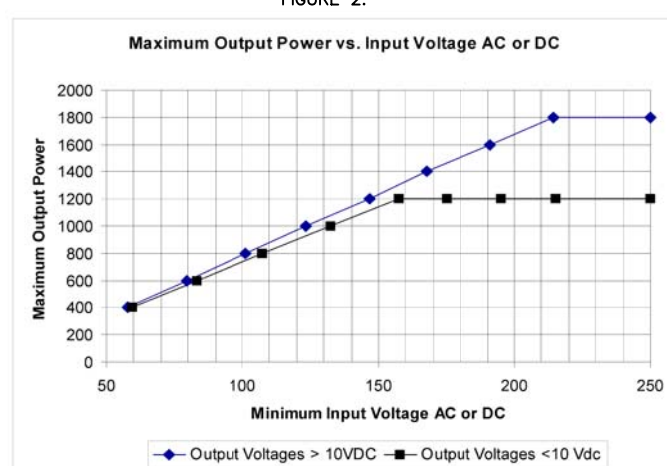

- ELECTRICAL SPECIFICATIONS: CONTINUED.

OUTPUT REQUIREMENTS:

NUMBER OF OUTPUTS: 1
OUTPUT VOLTAGE: (SEE TABULATION ON SHEET 2).
OUTPUT ADJUSTMENT: 95% OF V NOM MIN., 105% OF V NOM MAX.
SETPOINT ACCURACY: ±0.5% OF V NOM TYP., ±1% OF V NOM MAX.
LOAD REGULATION: ±0.2% OF V NOM MAX., 0% TO 100% LOAD
LINE REGULATION: ±0.2% FROM 10% LOAD TO FULL LOAD
OUTPUT RIPPLE-PP: 1% TYP., 20 MHz BANDWIDTH
TEMPERATURE REGULATION: 0.002°C TYP., 0.005°C MAX., -40 TO 65°C
LONG TERM DRIFT: 0.02%/1K HOURS TYP.
TOTAL REMOTE SENSE COMPENSATION: 0.25 VDC EACH SENSE LINE.
OVP SET POINT: MIN. 112% OF V MAX., MAX. 135% OF V MAX., AUTOMATIC RESTART
MAXIMUM OUTPUT POWER: (SEE INPUT RATING CHART).

OTHER REQUIREMENTS:

POWER SUPPLY INHIBIT: WITH THE POWER SUPPLY INHIBIT AT A HIGH LEVEL OR OPEN, THE POWER SUPPLY SHALL BE ENABLED REGARDLESS OF THE STATE OF POWER SUPPLY ENABLE.

POWER SUPPLY ENABLE: CONNECTING POWER SUPPLY INHIBIT AND POWER SUPPLY ENABLE TO SIGNAL RETURN SHALL CAUSE THE POWER SUPPLY TO OPERATE. IN THIS CONFIGURATION, PLACING A HIGH LEVEL OR OPEN ON POWER SUPPLY ENABLE WILL CAUSE THE POWER SUPPLY TO BE DISABLED.

INHIBIT	ENABLE	POWER SUPPLY STATE
1	X	ON
0	0	ON
0	1	OFF

1 = TTL HIGH OR OPEN CIRCUIT
0 = TTL LOW OR CLOSED CIRCUIT
X = DON'T CARE

AC POWER OK: TTL ACTIVE HIGH SIGNAL. MINIMUM 3ms HOLD UP TIME @ 1200 WATTS LOAD

OVER-TEMPERATURE PROTECTION: OUTPUT THERMAL LIMITING 100°C, INPUT LIMITING 90°C

DCOK: SIGNAL WILL INDICATE WHEN THE OUTPUT VOLTAGE IS OUT OF TOLERANCE (±4 TO ±6%)

UNIT TO UNIT PARALLEL OPERATION: POWER SUPPLY SHALL OPERATE WITH UP TO THREE POWER SUPPLIES CONNECTED IN PARALLEL, PROVIDED EACH POWER SUPPLY IS OF LIKE POWER AND VOLTAGE RATING AND IS POWERED FROM THE SAME INPUT VOLTAGE SOURCE. THE FULL LOAD CURRENT SHARING ACCURACY OF EACH POWER SUPPLY IN PARALLEL SHALL BE WITHIN 10% OF THE SUM OF THE RATINGS OF POWER SUPPLIES IN PARALLEL.

- COMPLIANCE REQUIREMENTS:

RADIATED EMISSIONS: MIL-STD-461E RE101-1, RE101-2, RE102-1, UPPER CURVE
SUSCEPTIBILITY: MIL-STD-461E CS101-1; CS114-1, CURVE 2; RS103-1
SAFETY APPROVALS: DESIGNED TO MEET UL 1950, CSA C22.2 NO.234, IEC 950, EN 60950
DIELECTRIC WITHSTAND: PRIMARY TO CHASSIS GND=2121 VDC/PRIMARY TO SECONDARY=2121 VDC/SECONDARY TO CHASSIS GND=50 VDC

- ENVIRONMENTAL REQUIREMENTS:

OPERATING TEMPERATURE: C-GRADE -20°C TO +55°C, T AND H-GRADE -40°C TO +55°C, M-GRADE -55°C TO +55°C
LINEAR DERATE TO 50% POWER BETWEEN 55°C AND 70°C (REFER TO FIGURE 3).
STORAGE TEMPERATURE: C AND T-GRADE -40°C TO +125°C, H-GRADE -55°C TO +125°C, M-GRADE -65°C TO +125°C
VIBRATION: MIL-STD-167-1, TYPE 1 SINE 4-50HZ.
SHOCK: MIL-S-901, LIGHTWEIGHT CLASS 1 (5FT. HAMMER BLOW W/57 LB LOAD)
ALTITUDE: 15000 FT MAXIMUM OPERATING AND NON-OPERATING.
BENCH HANDLING: MIL-STD-810, METHOD 516.4 PROCEDURE V1.
HUMIDITY: 95% NON-CONDENSING, OPERATING AND NON-OPERATING.

WITH OPTIONAL CONFORMAL COATING: (700-0180-XXX-C)

HUMIDITY: 100% CONDENSING, MIL-STD-810, METHOD 507 OPERATING AND NON-OPERATING.

SALT ATMOSPHERE: MIL-STD-810, METHOD 509 OPERATING AND NON-OPERATING.

FUNGUS: MIL-STD-810, METHOD 508 OPERATING AND NON-OPERATING.

- SIZE: 4.9" H X 7.00" W X 10.75" L MAXIMUM

- WEIGHT: 11.5 LBS MAXIMUM.

- ASSEMBLY IDENTIFIED WITH MISSION POWER SOLUTIONS PRODUCT LABEL APPROX. WHERE SHOWN.

- VENDOR:
MISSION POWER SOLUTIONS INC.
4168 AVENIDA DE LA PLATA
SUITE #105
OCEANSIDE, CA 92056-6030
SALES@MPWRS.COM
TEL: (760) 631-6846
FAX: (760) 631-6972
MPS PART NO. : 700-0180-XXX-X (REFER TO OUTPUT RATING AND PART NUMBER TABULATION ON SHEET 2)
CUSTOMER PART NO. : TBD

FIGURE 3.

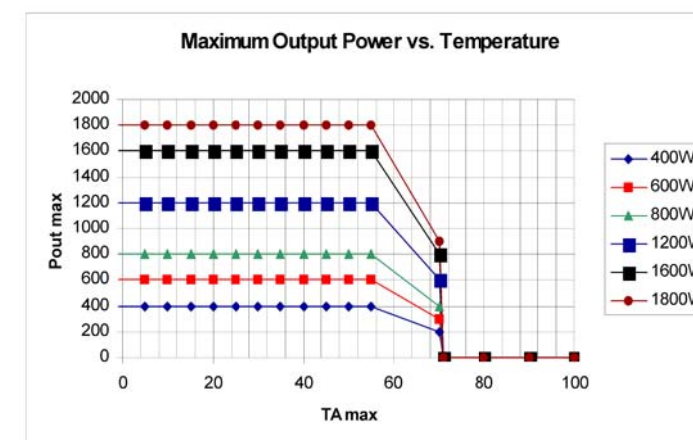

DESIGN ACKNOWLEDGMENT:
ALL MECHANICAL AND ELECTRICAL SPECIFICATIONS HAVE BEEN REVIEWED AND ARE CORRECT.

SIGNATURE

PRINTED NAME DATE

TITLE

CONTROL DRAWING



04-05-27

CONFIDENTIALITY NOTICE
THIS DOCUMENT AND THE DATA DISCLOSED HEREIN OR HEREWITH IS NOT TO BE USED, REPRODUCED, OR DISCLOSED IN WHOLE OR IN PART TO ANYONE WITHOUT THE WRITTEN CONSENT OF MISSION POWER SOLUTIONS OR VICOR CORP.

THIRD ANGLE PROJECTION		CONTRACT NO.		MISSION POWER SOLUTIONS	
UNLESS OTHERWISE SPECIFIED DIMENSIONS ARE IN INCHES.		APPROVALS	DATE	TITLE	
TOLERANCES ARE: DECIMALS .XX ± .03 ANGLES ± 1°		DRAWN R. MILLER	03/08/15	POWER SUPPLY, SINGLE PHASE, JAVELIN I	
DO NOT SCALE DRAWING		CHECKED		SIZE CAGE CODE DWG NO. D1FWR8700-0180-XXX B	
		ENGR R. MILLER	03/08/15	SCALE 1/1 F/M 700-0180-XXX-B-1 SHEET 1 OF 4	

700-0180-XXX-X

MODEL NUMBER

SEE CHART BELOW

OPTION CODE:
BLANK = NO OPTION SELECTED
C = CONFORMAL COATING

REVISION		DATE	APPROVED
REV	DESCRIPTION		
-	SEE SHEET 1		

OUTPUT RATING AND PART NUMBER TABULATION

C-GRADE						T-GRADE					
DASH #	OUTPUT VOLTAGE	OUTPUT POWER (WATTS)	OUTPUT CURRENT (ADC)	INPUT RATING	INPUT TYPE (#)	DASH #	OUTPUT VOLTAGE	OUTPUT POWER (WATTS)	OUTPUT CURRENT (ADC)	INPUT RATING	INPUT TYPE (#)
101	2	160	80	1	1,2	125	2	160	80	1	1,2
102	2	320	160	1	1,2	126	2	320	160	1	1,2
103	2	480	240	1	1,2	127	2	480	240	1	1,2
104	3.3	264	80	1	1,2	128	3.3	264	80	1	1,2
105	3.3	528	160	1	1,2	129	3.3	528	160	1	1,2
106	3.3	792	240	1, 2	1,2	130	3.3	792	240	1, 2	1,2
107	5	400	80	1	1,2	131	5	400	80	1	1,2
108	5	800	160	1, 2	1,2	132	5	800	160	1, 2	1,2
109	5	1200	240	1, 2, 3	1,2	133	5	1200	240	1, 2, 3	1,2
110	12	600	50	1	1,2	134	12	600	50	1	1,2
111	12	1200	100	1, 2, 3	1,2	135	12	1200	100	1, 2, 3	1,2
112	12	1800	150	1, 2, 3, 4, 5	1,2	136	12	1800	150	1, 2, 3, 4, 5	1,2
113	15	600	40	1	1,2	137	15	600	40	1	1,2
114	15	1200	80	1, 2, 3	1,2	138	15	1200	80	1, 2, 3	1,2
115	15	1800	120	1, 2, 3, 4, 5	1,2	139	15	1800	120	1, 2, 3, 4, 5	1,2
116	24	600	25	1	1,2	140	24	600	25	1	1,2
117	24	1200	50	1, 2, 3	1,2	141	24	1200	50	1, 2, 3	1,2
118	24	1800	75	1, 2, 3, 4, 5	1,2	142	24	1800	75	1, 2, 3, 4, 5	1,2
119	28	600	21.4	1	1,2	143	28	600	21.4	1	1,2
120	28	1200	42.8	1, 2, 3	1,2	144	28	1200	42.8	1, 2, 3	1,2
121	28	1800	64.3	1, 2, 3, 4, 5	1,2	145	28	1800	64.3	1, 2, 3, 4, 5	1,2
122	48	600	12.5	1	1,2	146	48	600	12.5	1	1,2
123	48	1200	24	1, 2, 3	1,2	147	48	1200	24	1, 2, 3	1,2
124	48	1800	37.5	1, 2, 3, 4, 5	1,2	148	48	1800	37.5	1, 2, 3, 4, 5	1,2

H-GRADE						M-GRADE					
DASH #	OUTPUT VOLTAGE	OUTPUT POWER (WATTS)	OUTPUT CURRENT (ADC)	INPUT RATING	INPUT TYPE (#)	DASH #	OUTPUT VOLTAGE	OUTPUT POWER (WATTS)	OUTPUT CURRENT (ADC)	INPUT RATING	INPUT TYPE (#)
149	2	160	80	1	1,2	173	2	160	80	1	1,2
150	2	320	160	1	1,2	174	2	320	160	1	1,2
151	2	480	240	1	1,2	175	2	480	240	1	1,2
152	3.3	264	80	1	1,2	176	3.3	264	80	1	1,2
153	3.3	528	160	1	1,2	177	3.3	528	160	1	1,2
154	3.3	792	240	1, 2	1,2	178	3.3	792	240	1, 2	1,2
155	5	400	80	1	1,2	179	5	400	80	1	1,2
156	5	800	160	1, 2	1,2	180	5	800	160	1, 2	1,2
157	5	1200	240	1, 2, 3	1,2	181	5	1200	240	1, 2, 3	1,2
158	12	600	50	1	1,2	182	12	600	50	1	1,2
159	12	1200	100	1, 2, 3	1,2	183	12	1200	100	1, 2, 3	1,2
160	12	1800	150	1, 2, 3, 4, 5	1,2	184	12	1800	150	1, 2, 3, 4, 5	1,2
161	15	600	40	1	1,2	185	15	600	40	1	1,2
162	15	1200	80	1, 2, 3	1,2	186	15	1200	80	1, 2, 3	1,2
163	15	1800	120	1, 2, 3, 4, 5	1,2	187	15	1800	120	1, 2, 3, 4, 5	1,2
164	24	600	25	1	1,2	188	24	600	25	1	1,2
165	24	1200	50	1, 2, 3	1,2	189	24	1200	50	1, 2, 3	1,2
166	24	1800	75	1, 2, 3, 4, 5	1,2	190	24	1800	75	1, 2, 3, 4, 5	1,2
167	28	600	21.4	1	1,2	191	28	600	21.4	1	1,2
168	28	1200	42.8	1, 2, 3	1,2	192	28	1200	42.8	1, 2, 3	1,2
169	28	1800	64.3	1, 2, 3, 4, 5	1,2	193	28	1800	64.3	1, 2, 3, 4, 5	1,2
170	48	600	12.5	1	1,2	194	48	600	12.5	1	1,2
171	48	1200	24	1, 2, 3	1,2	195	48	1200	24	1, 2, 3	1,2
172	48	1800	37.5	1, 2, 3, 4, 5	1,2	196	48	1800	37.5	1, 2, 3, 4, 5	1,2



04-05-27

REVISION			
REV	DESCRIPTION	DATE	APPROVED
-	SEE SHEET 1		

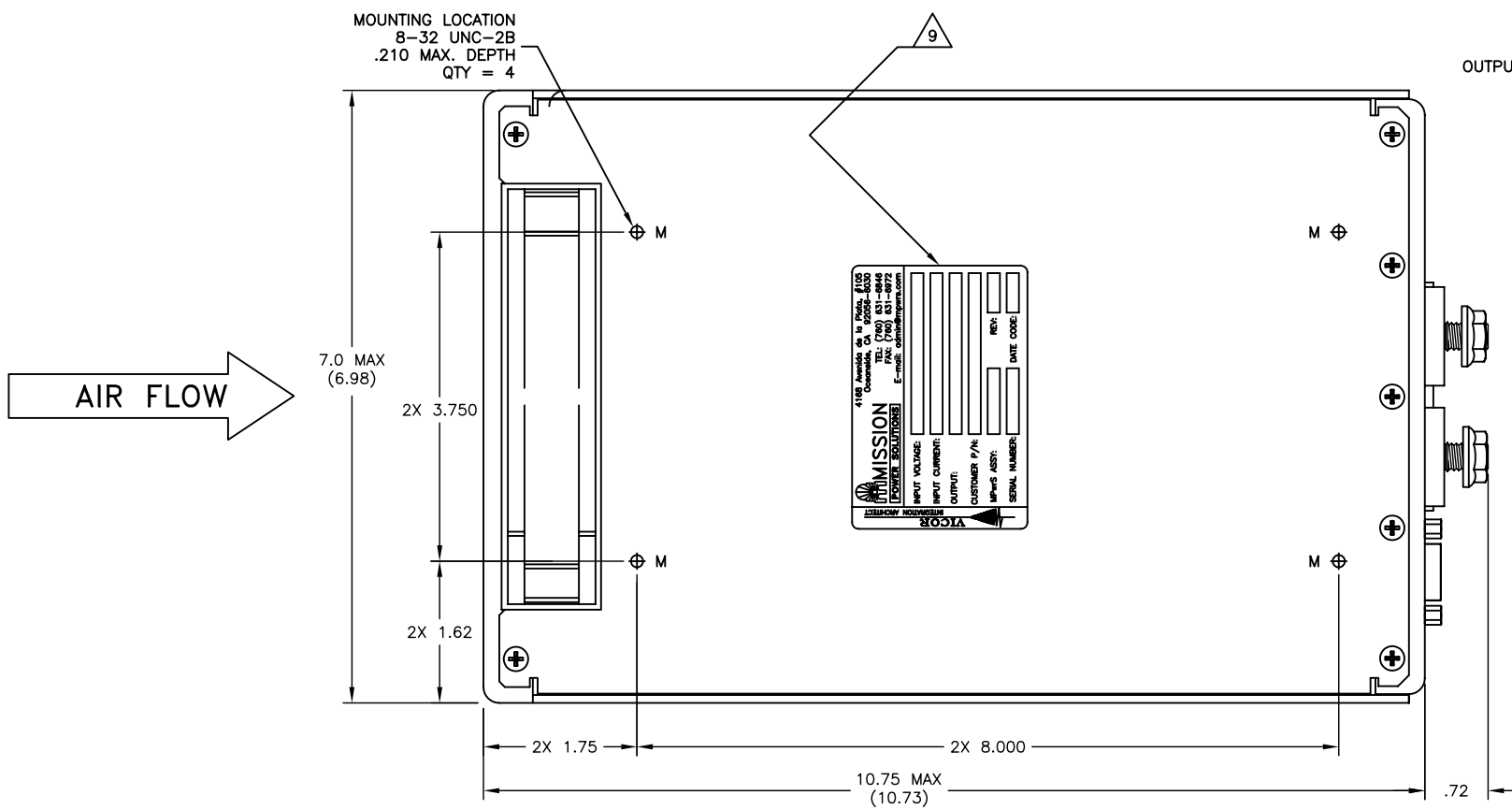

TOP VIEW

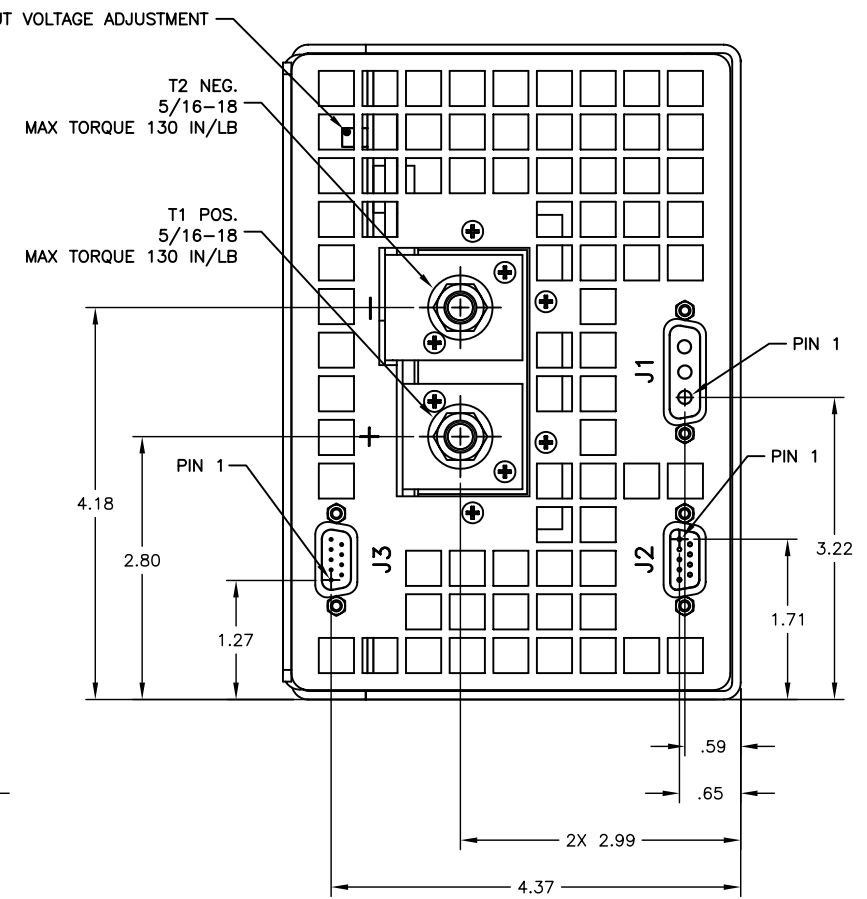

REAR VIEW

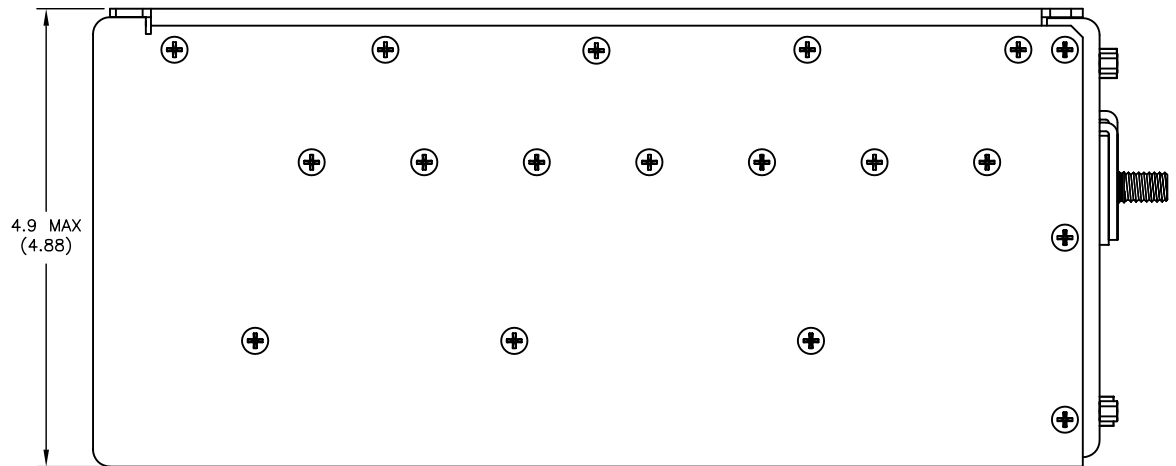

LEFT SIDE VIEW

RELEASED

04-05-27

SIZE	CAGE CODE	DWG NO.	REV.
D	1FWR8	700-0180-XXX	B
SCALE	700-0180-XXX-B-3		SHEET 3 OF 4

8 7 6 5 4 3 2 1

REVISION			
REV	DESCRIPTION	DATE	APPROVED
-	SEE SHEET 1		

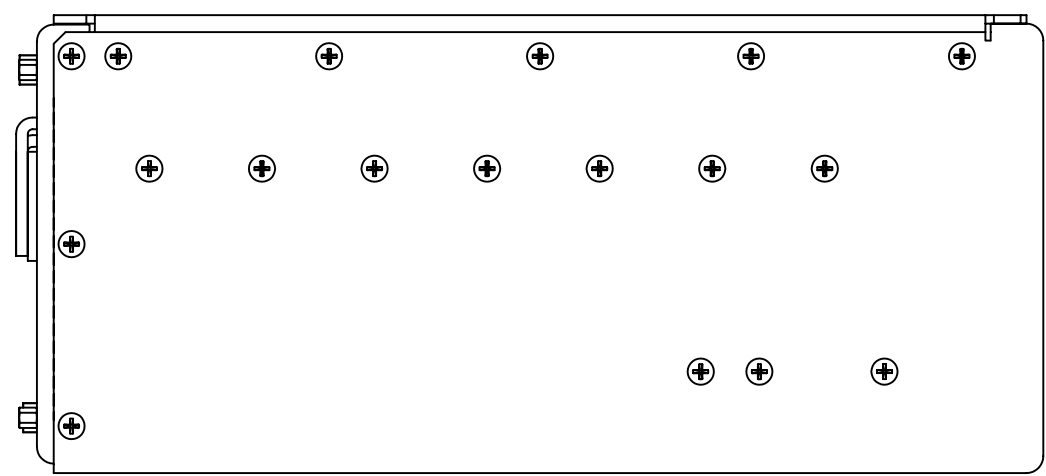

RIGHT SIDE VIEW

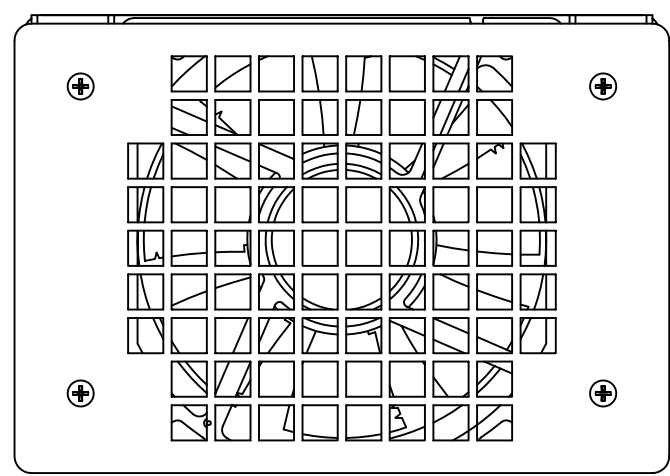

FRONT VIEW

MOUNTING LOCATION
 8-32 UNC-2B
 .210 MAX. DEPTH
 QTY = 4

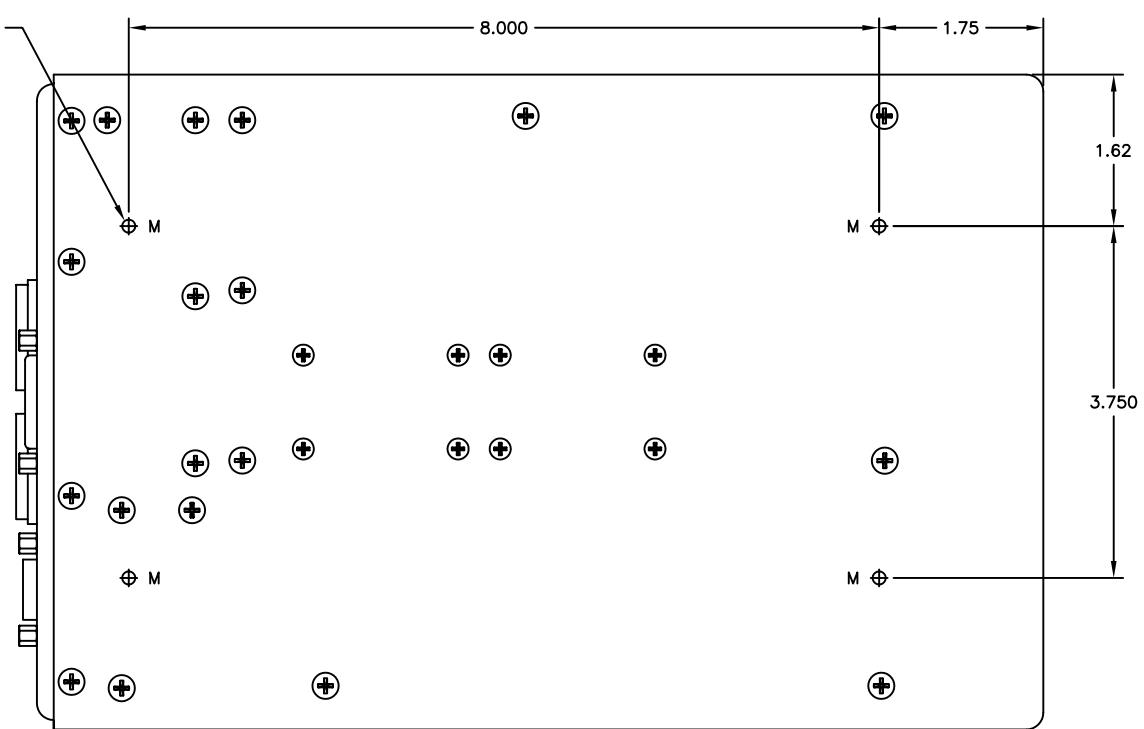

BOTTOM VIEW

RELEASED

04-05-27

8 7 6 5 4 3 2 1

SIZE	CAGE CODE	DWG NO.	REV.
D11FWR8	700-0180-XXX	B	
SCALE	700-0180-XXX-B-4		SHEET 4 OF 4