

PI2122 Features

- Integrated High Performance 12 A, 6 mΩ, 7 V Dual back-to-back MOSFET
- Combines a high-speed ORing MOSFET and load disconnect controller with very low resistance back-to-back MOSFETs
- Very-small, high density fully-optimized solution providing simple PCB layout with 50% space savings
- Fast dynamic response with 140 ns reverse and 170 ns forward over-current turn-off delay time
- Accurate sensing capability to indicate system fault conditions
- Programmable under & over-voltage functions
- Over temperature shutdown
- Programmable over current duty cycle
- Programmable short circuit load detection function
- Active low fault flag output

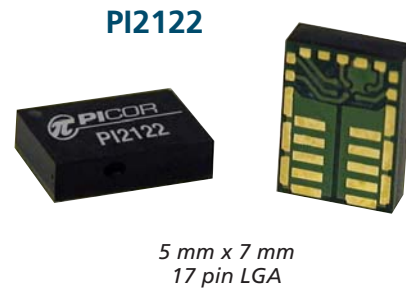

Product Description

The Cool-ORing™ PI2122 is a complete full-function Active ORing solution with a high-speed ORing MOSFET controller and very low on-state resistance back-to-back configured Dual MOSFETs designed for use in redundant power system architectures where added protection against load fault conditions is required. The back-to-back MOSFET provides a true bi-directional switch capability to disconnect load fault conditions that may induce excessive forward current and device over-temperature. The gate drive is removed from the back-to-back MOSFETs upon detection of such faults and has an auto-retry programmable off-time. The PI2122 Cool-ORing solution is offered in an extremely small, thermally enhanced LGA package and can be used in low voltage ($\leq 5V_{bus}$) high side Active ORing applications. The PI2122 enables extremely low power loss with fast dynamic response to fault conditions, critical for high availability systems. A short circuit detection feature allows user definition of a short condition enabling minimum duty cycle

into a short. The over current duty cycle feature provides capacitor selectable duty cycle protection controlling the rate of temperature increase during a load fault condition.

The PI2122 provides very high efficiency and low power loss during steady state operation, while achieving high-speed turn-off of the internal MOSFETs under a variety of potential system-level fault conditions with auto-reset once the fault clears. The PI2122 detects normal forward, excessive forward and reverse current flow through the internal MOSFET, and the status is reported via an active low fault flag output. A temperature sensing function turns off the MOSFETs and indicates a fault if the controller junction temperature exceeds 145°C. The under-voltage, over-voltage and short circuit detect thresholds are programmable via external resistor dividers.

Part Numbering

Part Number	Package	Voltage Rating	Current Handling	Target Application	Internal Back-to-Back MOSFET On-Resistance	Bias Supply	Turn-off Delay Time	Transport Media
PI2122-00-LGIZ	5x7mm 17-pin LGA	7 V (max.)	12 A (max.)	≤ 5 V bus	6 mΩ (typ.)	4.5 V – 13.2 V	Reverse 140 ns (typ.) Forward Over-Current 170 ns (typ.)	Tape and Reel

Evaluation Board

PI2122-EVAL1 PI2122 Evaluation Board configured for a high side application.

Applications

- N+1 Redundant Power Systems
- Servers & High End Computing
- High-side Active ORing
- High current Active ORing ($\leq 5 V_{bus}$)

Typical Application

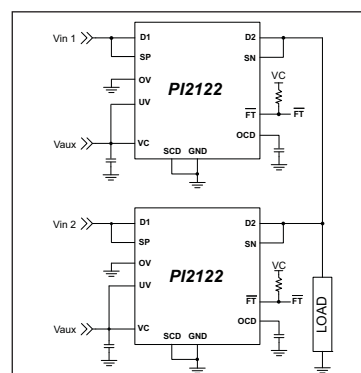

PI2122 High Side Active ORing with Load Disconnect