



Micro Family 28V Wide Input

Actual size:
2.28 x 1.45 x 0.5in
57,9 x 36,8 x 12,7mm



DC-DC Converter Module

Features & Benefits

- DC input range: 9 – 36V*
- Isolated output
- Input surge withstand: 50V for 100ms
- DC output: 3.3 – 48V
- Programmable output: 10 to 110%
- Regulation: $\pm 0.2\%$ no load to full load
- Efficiency: Up to 81%
- Maximum operating temp: 100°C, full load
- Power density: up to 60W per cubic inch
- Height above board: 0.43in. (10,9mm)
- Parallelable, with N+M fault tolerance
- Low noise ZCS / ZVS architecture
- RoHS Compliant (with F or G pin option)

Product Overview

These DC-DC converter modules use advanced power processing, control and packaging technologies to provide the performance, flexibility, reliability and cost effectiveness of a mature power component.

High frequency ZCS / ZVS switching provides high power density with low noise and high efficiency.

*Derate power to 75% for 9 to 10V_{IN}

Applications

Industrial and process control, distributed power, medical, ATE, communications, defense and aerospace.

For details on proper operation please refer to the:
[Design Guide & Applications Manual for Maxi, Mini, Micro Family.](#)

Absolute Maximum Ratings

| Parameter | Rating | Unit | Notes |
|---------------------------|--------------|------------------|---------------------|
| +IN to -IN voltage | -0.5 to +53 | V _{DC} | |
| PC to -IN voltage | -0.5 to +7.0 | V _{DC} | |
| PR to -IN voltage | -0.5 to +7.0 | V _{DC} | |
| SC to -OUT voltage | -0.5 to +1.5 | V _{DC} | |
| Isolation voltage | | | |
| IN to OUT | 3000 | V _{RMS} | Test voltage |
| IN to base | 1500 | V _{RMS} | Test voltage |
| OUT to base | 500 | V _{RMS} | Test voltage |
| Operating Temperature | -55 to +100 | °C | M-Grade |
| Storage Temperature | -65 to +125 | °C | M-Grade |
| Pin soldering temperature | 500 (260) | °F (°C) | <5 sec; wave solder |
| | 750 (390) | °F (°C) | <7 sec; hand solder |
| Mounting torque | 5 (0.57) | in-lbs (N-m) | 6 each |

Part Numbering

e.g. V28C12T100BL2

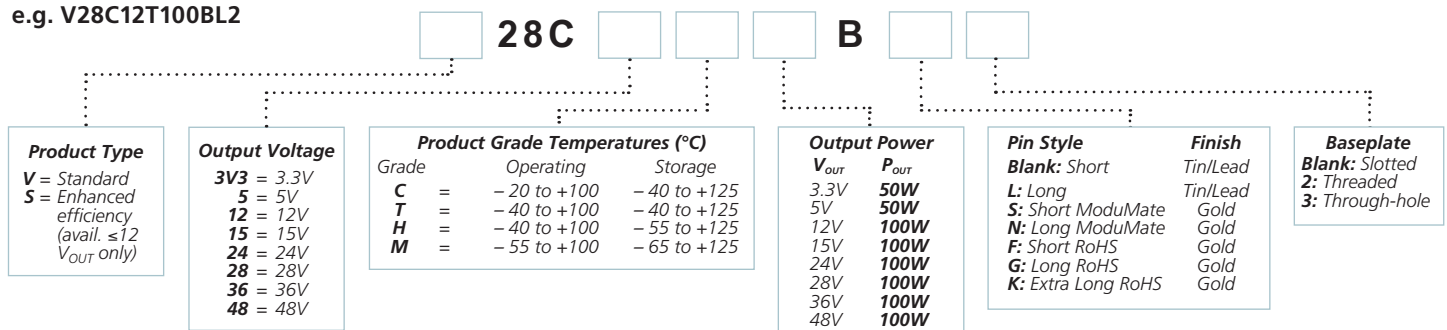

Module Family Electrical Characteristics

Electrical characteristics apply over the full operating range of input voltage, output load (resistive) and baseplate temperature, unless otherwise specified. All temperatures refer to the operating temperature at the center of the baseplate.

MODULE INPUT SPECIFICATIONS

| Parameter | Min | Typ | Max | Unit | Notes |
|---------------------------|------|------|------|-----------------|---|
| Operating input voltage | 9 | 28 | 36 | V _{DC} | From 9 to 10V input available power is reduced to 75% of max rating |
| Input surge withstand | | | 50 | V _{DC} | <100ms |
| Undervoltage turn-on | | 8.8 | 8.9 | V _{DC} | |
| Undervoltage turn-off | | 8.5 | | V _{DC} | |
| Overvoltage turn-off / on | 36.3 | 37.8 | 39.6 | V _{DC} | |
| Disabled input current | | 12 | 14 | mA | PC pin low |

MODULE OUTPUT SPECIFICATIONS

| Parameter | Min | Typ | Max | Unit | Notes |
|--|-----|--------|--------|--------------|---|
| Output voltage set point | | | ±1 | % | Of nominal output voltage. Nominal input; full load; 25°C |
| Line regulation | | ±0.02 | ±0.20 | % | Low line to high line; full load |
| Temperature regulation | | ±0.002 | ±0.005 | % / °C | Over operating temperature range |
| Power sharing accuracy | | ±2 | ±5 | % | 10 to 100% of full load |
| Programming range | 10 | | 110 | % | Of nominal output voltage. For trimming below 90% of nominal, a minimum load of 10% of maximum rated power may be required. |
| +OUT to -OUT — Absolute Maximum Ratings | | | | | |
| 3.3V | | | | -0.5 to 4.7 | V _{DC} Externally applied |
| 5V | | | | -0.5 to 7.0 | V _{DC} Externally applied |
| 8V | | | | -0.5 to 10.9 | V _{DC} Externally applied |
| 12V | | | | -0.5 to 16.1 | V _{DC} Externally applied |
| 15V | | | | -0.5 to 20.0 | V _{DC} Externally applied |
| 24V | | | | -0.5 to 31.7 | V _{DC} Externally applied |
| 28V | | | | -0.5 to 36.9 | V _{DC} Externally applied |
| 36V | | | | -0.5 to 47.1 | V _{DC} Externally applied |
| 48V | | | | -0.5 to 62.9 | V _{DC} Externally applied |

Note: The permissible load current must never be exceeded during normal, abnormal or test conditions. For additional output related application information, please refer to output connections on page 7.

THERMAL RESISTANCE AND CAPACITY

| Parameter | Min | Typ | Max | Unit |
|--|-----|------|-----|-------------|
| Baseplate to sink; flat, greased surface | | 0.24 | | °C/Watt |
| Baseplate to sink; thermal pad (P/N 20265) | | 0.21 | | °C/Watt |
| Baseplate to ambient | | 10.9 | | °C/Watt |
| Baseplate to ambient; 1000LFM | | 2.8 | | °C/Watt |
| Thermal capacity | | 48 | | Watt-sec/°C |

Module Family Electrical Characteristics (Cont.)

MODULE CONTROL SPECIFICATIONS

| Parameter | Min | Typ | Max | Unit | Notes |
|---|------|-------|------|------------------|--|
| Primary Side (PC = Primary Control; PR = Parallel) | | | | | |
| PC bias voltage | 5.50 | 5.75 | 6.00 | V _{DC} | PC current = 1.0mA |
| current limit | 1.5 | 2.1 | 3.0 | mA | PC voltage = 5.5V |
| PC module disable | 2.3 | 2.6 | 2.9 | V _{DC} | Switch must be able to sink ≥4mA. See Fig. 2 |
| PC module enable delay | | 4 | 7 | ms | |
| PC module alarm | | | 0.5 | V _{avg} | UV, OV, OT, module fault. See Figs. 3 and 5 |
| PC resistance | 0.9 | 1.0 | 1.1 | MΩ | See Fig. 3, converter off or fault mode |
| PR emitter amplitude | 5.7 | 5.9 | 6.1 | Volts | PR load >30Ω, <30pF |
| PR emitter current | 150 | | | mA | |
| PR receiver impedance | 375 | 500 | 625 | Ω | 25°C |
| PR receiver threshold | 2.4 | 2.5 | 2.6 | Volts | Minimum pulse width: 20ns |
| PR drive capability | | | 12 | modules | Without PR buffer amplifier |
| Secondary Side (SC = Secondary Control) | | | | | |
| SC bandgap voltage | 1.21 | 1.23 | 1.25 | V _{DC} | Referenced to –Sense |
| SC resistance | 990 | 1000 | 1010 | Ω | |
| SC capacitance | | 0.033 | | μF | |
| SC module alarm | | 0 | | V _{DC} | With open trim; referenced to –Sense. See Fig. 7 |

MODULE GENERAL SPECIFICATIONS

| Parameter | Min | Typ | Max | Unit | Notes |
|---------------------------------------|---------------|-------------------|---------------|-------------------|--|
| Isolation test voltage (IN to OUT)* | 3000 | | | V _{RMS} | Complies with reinforced insulation requirements |
| Isolation test voltage (IN to base)* | 1500 | | | V _{RMS} | Complies with basic insulation requirements |
| Isolation test voltage (OUT to base)* | 500 | | | V _{RMS} | Complies with operational insulation requirements |
| Isolation resistance | | 10 | | MΩ | IN to OUT, in to baseplate, out to baseplate |
| Weight (E, C, T grade) | 1.9 (52.8) | 2.1 (59.3) | 2.3 (65.8) | ounces (grams) | |
| Weight (H, M grade) | 2.1 (58.7) | 2.3 (65.2) | 2.5 (71.7) | ounces (grams) | |
| Temperature limiting | 100 | 115 | | °C | See Figs. 3 and 5. Do not operate converter >100°C. |
| Agency approvals | | cURus, cTUVus, CE | | | UL60950-1, EN60950-1, CSA60950-1, IEC60950-1. With appropriate fuse in series with the +Input |

* Isolation test voltage, 1 minute or less.

Note: Specifications are subject to change without notice.

MODULE SPECIFIC OPERATING SPECIFICATIONS

3.3V_{OUT}, 50W (e.g. S28C3V3C50BL, V28C3V3C50BL)

| Parameter | Min | Typ | Max | Unit | Notes |
|------------------------------------|------|-------|-------|-------|---|
| Efficiency | | | | | |
| S28C3V3C50BL (enhanced efficiency) | 73.7 | 83.6 | | % | Nominal input; full load; 25°C |
| V28C3V3C50BL (standard efficiency) | 72.0 | 73.4 | | | |
| Ripple and noise | | 180 | 225 | mV | p-p; Nominal input; full load; 20MHz bandwidth |
| Output OVP set point | 4.14 | 4.3 | 4.46 | Volts | 25°C; recycle input voltage or PC to restart (>100ms off) |
| Dissipation, standby | | 5.2 | 6.2 | Watts | No load |
| Load regulation | | ±0.02 | ±0.2 | % | No load to full load; nominal input |
| Load current | 0 | | 15.15 | Amps | |
| Current limit | 15.5 | 17.5 | 20.6 | Amps | Output voltage 95% of nominal |
| Short circuit current | 10.6 | 17.5 | 20.6 | Amps | Output voltage <250mV |

5V_{OUT}, 50W (e.g. S28C5C50BL, V28C5C50BL)

| Parameter | Min | Typ | Max | Unit | Notes |
|----------------------------------|------|-------|------|-------|---|
| Efficiency | | | | | |
| S28C5C50BL (enhanced efficiency) | 79.6 | 83.6 | | % | Nominal input; full load; 25°C |
| V28C5C50BL (standard efficiency) | 78.5 | 79.5 | | | |
| Ripple and noise | | 127 | 159 | mV | p-p; Nominal input; full load; 20MHz bandwidth |
| Output OVP set point | 6.03 | 6.25 | 6.47 | Volts | 25°C; recycle input voltage or PC to restart (>100ms off) |
| Dissipation, standby | | 2.9 | 3.5 | Watts | No load |
| Load regulation | | ±0.02 | ±0.2 | % | No load to full load; nominal input |
| Load current | 0 | | 10 | Amps | |
| Current limit | 10.2 | 11.5 | 13.5 | Amps | Output voltage 95% of nominal |
| Short circuit current | 7 | 11.5 | 13.5 | Amps | Output voltage <250mV |

12V_{OUT}, 100W (e.g. S28C12C100BL, V28C12C100BL)

| Parameter | Min | Typ | Max | Unit | Notes |
|------------------------------------|------|-------|------|-------|---|
| Efficiency | | | | | |
| S28C12C100BL (enhanced efficiency) | 82.0 | 85.0 | | % | Nominal input; full load; 25°C |
| V28C12C100BL (standard efficiency) | 81.0 | 82.3 | | | |
| Ripple and noise | | 200 | 250 | mV | p-p; Nominal input; full load; 20MHz bandwidth |
| Output OVP set point | 13.7 | 14.3 | 14.9 | Volts | 25°C; recycle input voltage or PC to restart (>100ms off) |
| Dissipation, standby | | 6.8 | 7.5 | Watts | No load |
| Load regulation | | ±0.02 | ±0.2 | % | No load to full load; nominal input |
| Load current | 0 | | 8.33 | Amps | |
| Current limit | 8.49 | 9.58 | 11.3 | Amps | Output voltage 95% of nominal |
| Short circuit current | 5.83 | 9.58 | 11.3 | Amps | Output voltage <250mV |

MODULE SPECIFIC OPERATING SPECIFICATIONS (CONT.)

15V_{OUT}, 100W (e.g. V28C15C100BL)

| Parameter | Min | Typ | Max | Unit | Notes |
|-----------------------|------|-------|------|-------|---|
| Efficiency | 79.0 | 80.7 | | % | Nominal input; full load; 25°C |
| Ripple and noise | | 200 | 250 | mV | p-p; Nominal input; full load; 20MHz bandwidth |
| Output OVP set point | 17.1 | 17.8 | 18.5 | Volts | 25°C; recycle input voltage or PC to restart (>100ms off) |
| Dissipation, standby | | 7.1 | 10 | Watts | No load |
| Load regulation | | ±0.02 | ±0.2 | % | No load to full load; nominal input |
| Load current | 0 | | 6.67 | Amps | |
| Current limit | 6.8 | 7.67 | 9.01 | Amps | Output voltage 95% of nominal |
| Short circuit current | 4.66 | 7.67 | 9.01 | Amps | Output voltage <250mV |

24V_{OUT}, 100W (e.g. V28C24C100BL)

| Parameter | Min | Typ | Max | Unit | Notes |
|-----------------------|------|-------|------|-------|---|
| Efficiency | 81.3 | 82.3 | | % | Nominal input; full load; 25°C |
| Ripple and noise | | 180 | 225 | mV | p-p; Nominal input; full load; 20MHz bandwidth |
| Output OVP set point | 27.1 | 28.1 | 29.1 | Volts | 25°C; recycle input voltage or PC to restart (>100ms off) |
| Dissipation, standby | | 5.3 | 6.2 | Watts | No load |
| Load regulation | | ±0.02 | ±0.2 | % | No load to full load; nominal input |
| Load current | 0 | | 4.17 | Amps | |
| Current limit | 4.25 | 4.8 | 5.63 | Amps | Output voltage 95% of nominal |
| Short circuit current | 2.91 | 4.8 | 5.63 | Amps | Output voltage <250mV |

28V_{OUT}, 100W (e.g. V28C28C100BL)

| Parameter | Min | Typ | Max | Unit | Notes |
|-----------------------|------|-------|------|-------|---|
| Efficiency | 79.0 | 80.6 | | % | Nominal input; full load; 25°C |
| Ripple and noise | | 160 | 200 | mV | p-p; Nominal input; full load; 20MHz bandwidth |
| Output OVP set point | 31.5 | 32.7 | 33.9 | Volts | 25°C; recycle input voltage or PC to restart (>100ms off) |
| Dissipation, standby | | 7.6 | 8.3 | Watts | No load |
| Load regulation | | ±0.02 | ±0.2 | % | No load to full load; nominal input |
| Load current | 0 | | 3.57 | Amps | |
| Current limit | 3.64 | 4.11 | 5.35 | Amps | Output voltage 95% of nominal |
| Short circuit current | 2.49 | 4.11 | 5.35 | Amps | Output voltage <250mV |

MODULE SPECIFIC OPERATING SPECIFICATIONS (CONT.)

36V_{OUTr} 100W (e.g. V28C36C100BL)

| Parameter | Min | Typ | Max | Unit | Notes |
|-----------------------|------|-------|------|-------|---|
| Efficiency | 79.5 | 80.9 | | % | Nominal input; full load; 25°C |
| Ripple and noise | | 180 | 225 | mV | p-p; Nominal input; full load; 20MHz bandwidth |
| Output OVP set point | 40.4 | 41.9 | 43.4 | Volts | 25°C; recycle input voltage or PC to restart (>100ms off) |
| Dissipation, standby | | 5.8 | 6.2 | Watts | No load |
| Load regulation | | ±0.02 | ±0.2 | % | No load to full load; nominal input |
| Load current | 0 | | 2.78 | Amps | |
| Current limit | 2.83 | 3.2 | 3.76 | Amps | Output voltage 95% of nominal |
| Short circuit current | 1.94 | 3.2 | 3.76 | Amps | Output voltage <250mV |

48V_{OUTr} 100W (e.g. V28C48C100BL)

| Parameter | Min | Typ | Max | Unit | Notes |
|-----------------------|------|-------|------|-------|---|
| Efficiency | 78.2 | 79.7 | | % | Nominal input; full load; 25°C |
| Ripple and noise | | 125 | 157 | mV | p-p; Nominal input; full load; 20MHz bandwidth |
| Output OVP set point | 53.7 | 55.7 | 57.7 | Volts | 25°C; recycle input voltage or PC to restart (>100ms off) |
| Dissipation, standby | | 7.4 | 8.0 | Watts | No load |
| Load regulation | | ±0.02 | ±0.2 | % | No load to full load; nominal input |
| Load current | 0 | | 2.08 | Amps | |
| Current limit | 2.12 | 2.39 | 3.31 | Amps | Output voltage 95% of nominal |
| Short circuit current | 1.45 | 2.39 | 3.31 | Amps | Output voltage <250mV |

Basic Module Operation

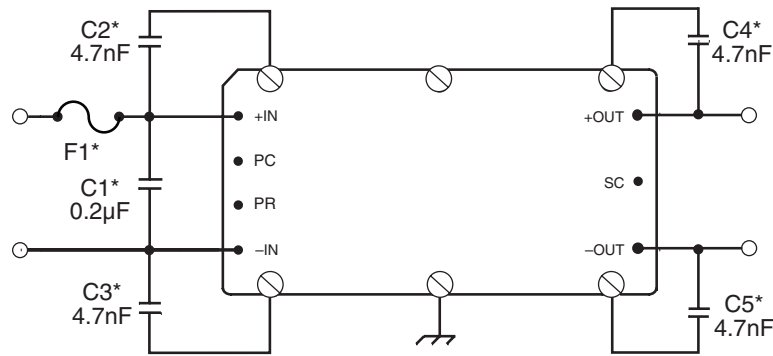

For C1 – C5, keep leads and connections short.

Figure 1 — Basic module operation requires fusing, grounding, bypassing capacitors.* See Maxi, Mini, Micro Design Guide.

Output Connections and Considerations

The permissible load current must never be exceeded during normal, abnormal or test conditions. Converters subject to dynamic loading exceeding 25% of rated current must be reviewed by Vicor Applications Engineering to ensure that the converter will operate properly.

Under dynamic load, light load, or no load conditions, the converter may emit audible noise. Converters that utilize remote sense may require compensation circuitry to offset the phase lag caused by the external output leads and load impedance. If an external remote sense circuit is used, the remote sense

leads must be protected for conditions such as lead reversal, noise pickup, open circuit, or excessive output lead resistance between the sense point and the converters output terminals. For applications that may draw more than the rated current, a fast acting electronic circuit breaker must be utilized to protect the converter. Under no circumstance should the rated current be exceeded. Utilizing or testing of current limit or short circuit current will damage the converter. Ensure that the total output capacitance connected to the converter does not exceed the limits on Page 16, "Maximum Output Capacitance", of the design guide.

Comprehensive Online Application Information



The Design Guide and Applications Manual includes:

- Application circuits
- Design requirements
- EMC considerations
- Current sharing in power arrays
- Thermal performance information
- Recommended soldering methods
- Accessory modules – filtering, rectification, front-ends
- Mounting options
- ...and more.

[CLICK HERE TO VIEW
DESIGN GUIDE](#)

Also at vicorpower.com

- PowerBench online configurators
- Over 20 Application Notes
- Online calculators – thermal, trimming, hold-up
- PDF data sheets for ALL Vicor products

Primary Control - PC PIN

Module Enable/Disable

The module may be disabled by pulling PC to 0V (2.3V max) with respect to the -Input. This may be done with an open collector transistor, relay, or optocoupler. Converters may be disabled with a single transistor or relay either directly or via "OR'ing" diodes for 2 or more converters. See Figure 2.

Primary Auxiliary Supply

During normal operation only, the PC Pin can source 5.7V @ 1.5mA. In the example shown in Figure 4, PC powers a module enabled LED.

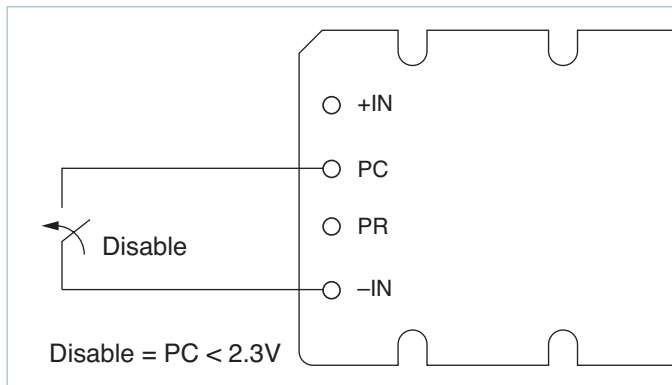

Figure 2 — Module enable/disable

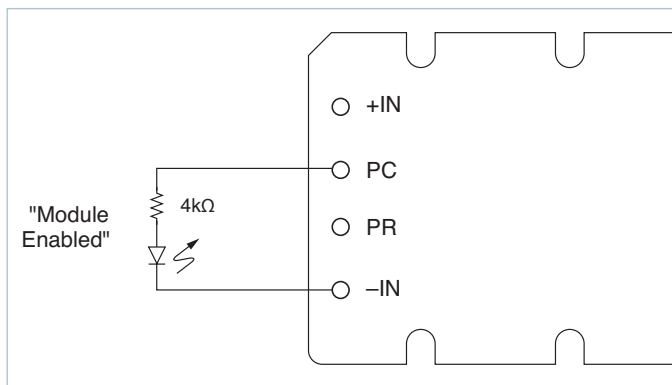

Figure 4 — LED on-state indicator

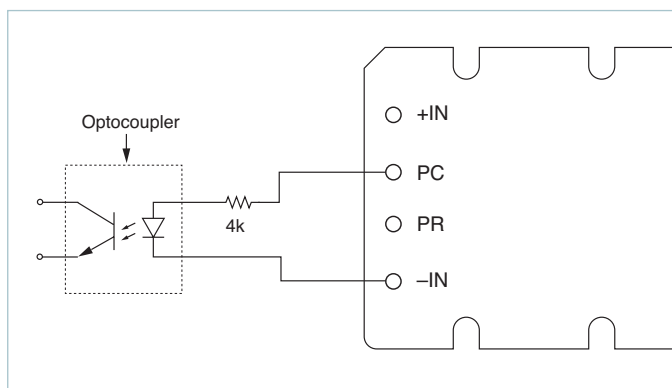

Figure 6 — Isolated on-state indicator

Module Alarm

The module contains "watchdog" circuitry which monitors input voltage, operating temperature and internal operating parameters. In the event that any of these parameters are outside of their allowable operating range, the module will shut down and PC will go low. PC will periodically go high and the module will check to see if the fault (as an example, Input Undervoltage) has cleared. If the fault has not been cleared, PC will go low again and the cycle will restart. The SC pin will go low in the event of a fault and return to its normal state after the fault has been cleared. See Figures 3 and 5.

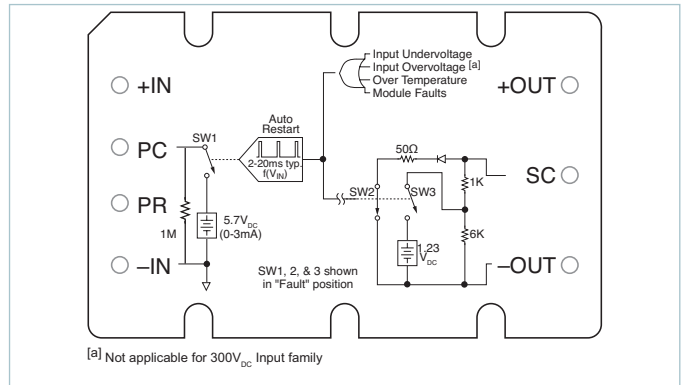

Figure 3 — PC/SC module alarm logic

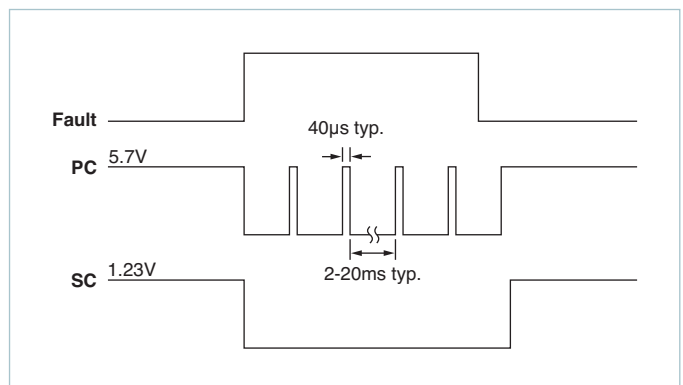

Figure 5 — PC/SC module alarm timing

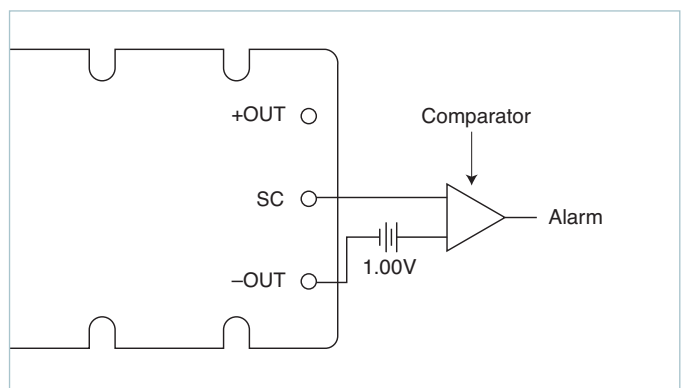

Figure 7 — Secondary side on-state indicator

Secondary Control - SC PIN

Output Voltage Programming

The output voltage of the converter can be adjusted or programmed via fixed resistors, potentiometers or voltage DACs. See Figure 8.

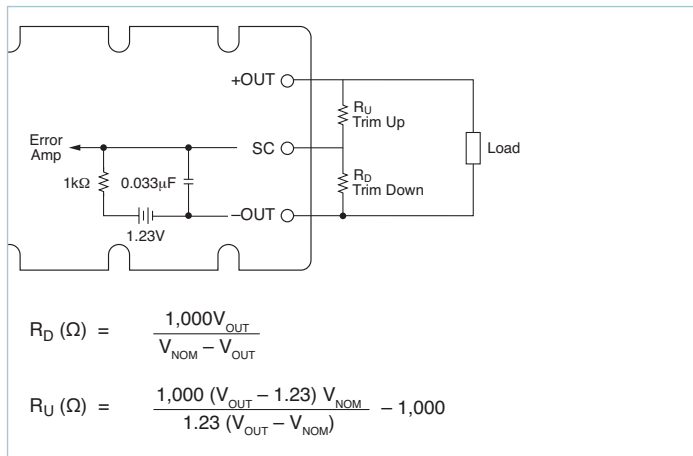

Figure 8 — Output voltage trim down and trim up circuit

Trim Down

1. This converter is not a constant power device – it has a constant current limit. Hence, available output power is reduced by the same percentage that output voltage is trimmed down. Do not exceed maximum rated output current.
2. The trim down resistor must be connected between the SC and -S pins. Do not bypass the SC pin directly with a capacitor.

Trim Up

1. The converter is rated for a maximum delivered power. To ensure that maximum rated power is not exceeded, reduce maximum output current by the same percentage increase in output voltage.
2. The trim up resistor must be connected between the SC and +S pins. Do not bypass the SC pin directly with a capacitor.
3. Do not trim the converter above maximum trim range (typically +10%) or the output over voltage protection circuitry may be activated.

Trim resistor values calculated automatically:

On-line calculators for trim resistor values are available on the vicor website at:

asp.vicorpower.com/calculators/calculators.asp?calc=1

Resistor values can be calculated for fixed trim up, fixed trim down and for variable trim up or down.

Parallel Bus - PR PIN

Parallel Operation

The PR pin supports paralleling for increased power with N+1 (N+M) redundancy. Modules of the same input voltage, output voltage, and power level will current share if all PR pins are suitably interfaced.

Compatible interface architectures include the following:

AC coupled single-wire interface. All PR pins are connected to a single communication bus through 0.001μF (500V) capacitors. This interface supports current sharing and is fault tolerant except for the communication bus. Up to three converters may be paralleled by this method. See Figure 9.

Transformer coupled interface. For paralleling four or more converters a transformer coupled interface is required, and under certain conditions a PR buffer circuit.

For details on parallel operation please refer to the

[Design Guide & Applications Manual for Maxi, Mini, Micro Family.](#)

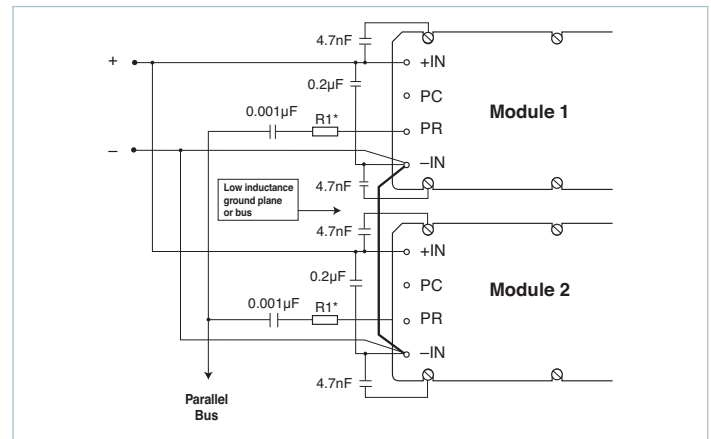

Figure 9 — AC coupled single-wire interface

* See Maxi, Mini, Micro Design Guide

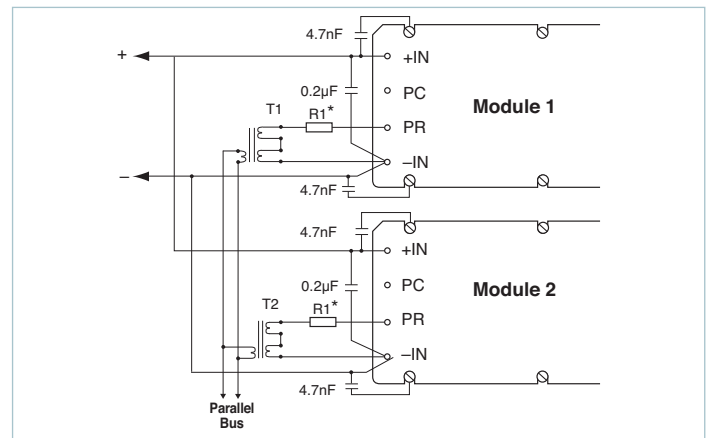

Figure 10 — Transformer-coupled interface

| Number of Converters in Parallel | *R1 value Ω |
|----------------------------------|---|
| 2 | 75 |
| 3 | 50 |
| 4 | 33 |
| 5 or more | refer to application note: Designing High-Power Arrays using Maxi, Mini, Micro Family DC-DC Converters |

Parallel Bus / Voltage Drop Compensation

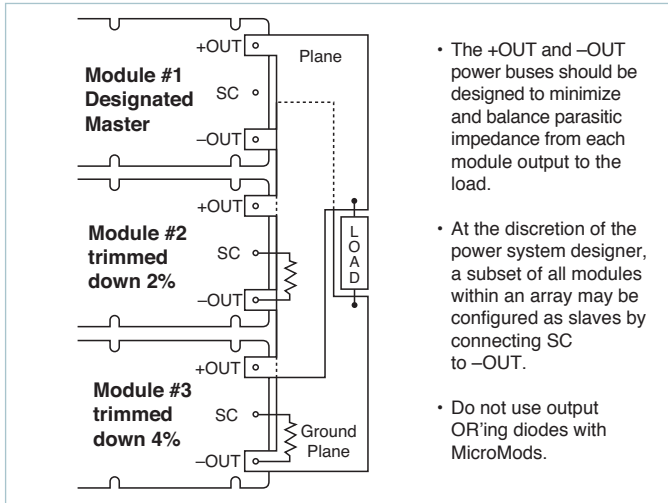

Figure 11 — N+1 module array output connections

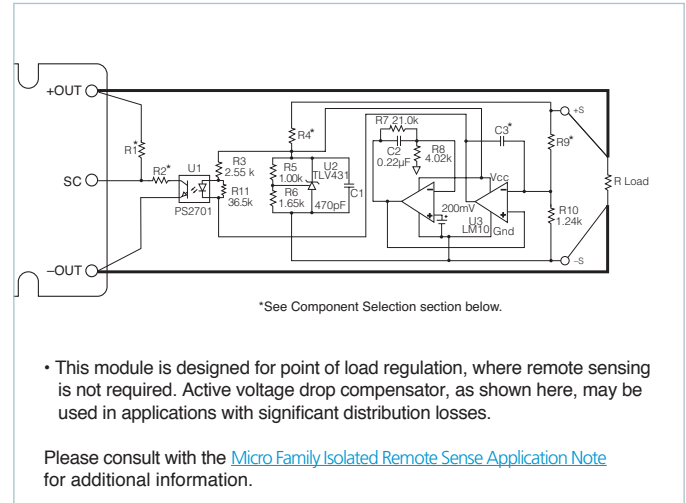

Figure 12 — Voltage drop compensation

PIN STYLES*

| Designator | Description | Finish | Notes |
|------------|-----------------|----------|--|
| (None) | Short | Tin/Lead | Requires in-board, mounting |
| L | Long | Tin/Lead | On-board mounting for 0.065" boards |
| S | Short ModuMate | Gold | SurfMate or in-board socket mounting |
| N | Long ModuMate | Gold | On-board socket mounting |
| F | Short RoHS | Gold | Select for RoHS compliant in-board solder, socket, or SurfMate mounting |
| G | Long RoHS | Gold | Select for RoHS compliant on-board solder or socket mounting |
| K | Extra Long RoHS | Gold | Select for RoHS compliance on-board mounting for thicker PCBs (not intended for socket or Surfmate mounting) |

* Pin style designator follows the "B" after the output power and precedes the baseplate designator.
Ex. V28C 12T100BN2 — Long ModuMate Pins

Storage

Vicor products, when not installed in customer units, should be stored in ESD safe packaging in accordance with ANSI/ESD S20.20, "Protection of Electrical and Electronic Parts, Assemblies and Equipment" and should be maintained in a temperature controlled factory/warehouse environment not exposed to outside elements controlled between the temperature ranges of 15°C and 38°C. Humidity shall not be condensing, no minimum humidity when stored in an ESD compliant package.

Mechanical Drawings

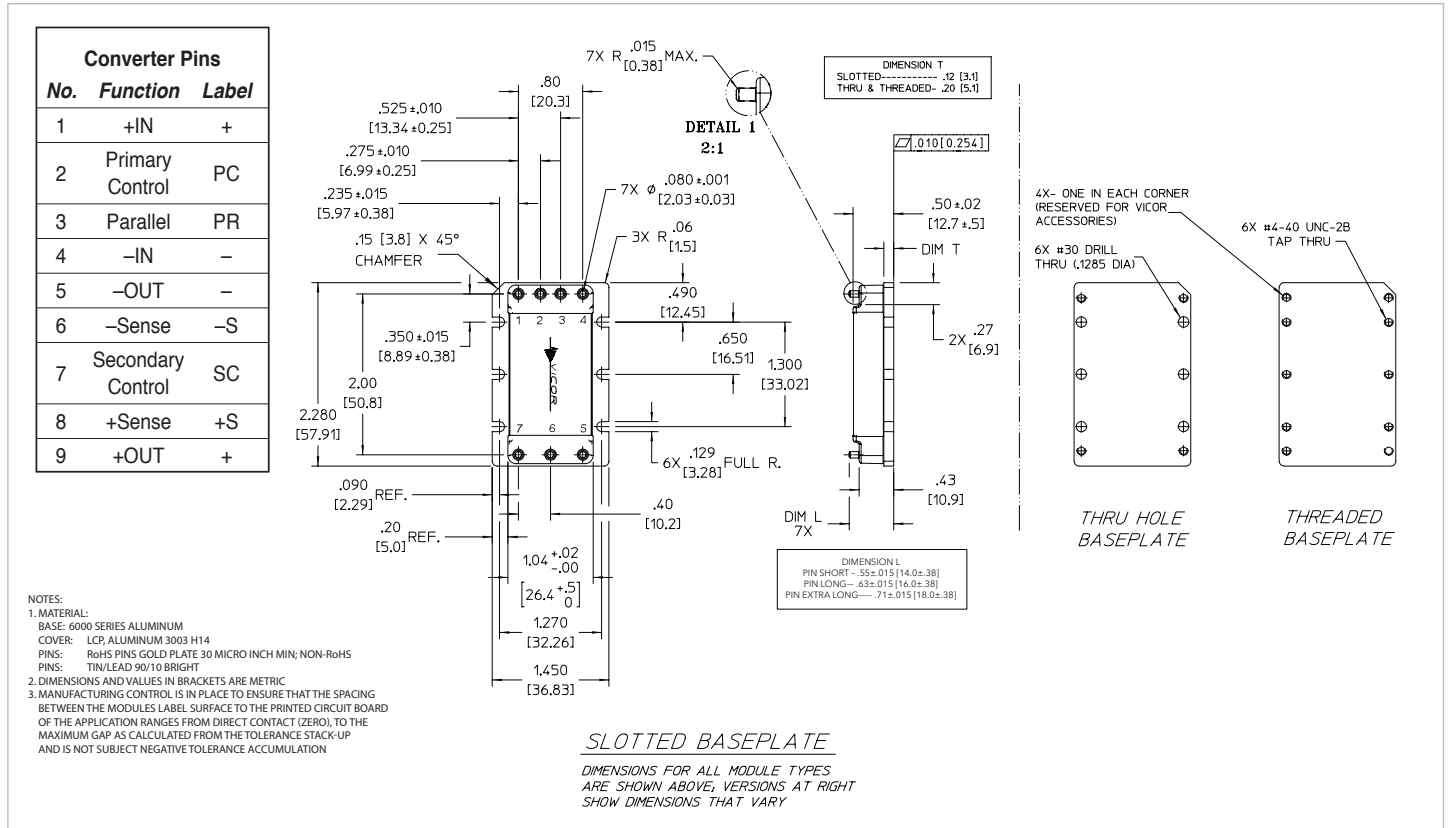

Figure 13 — Module outline

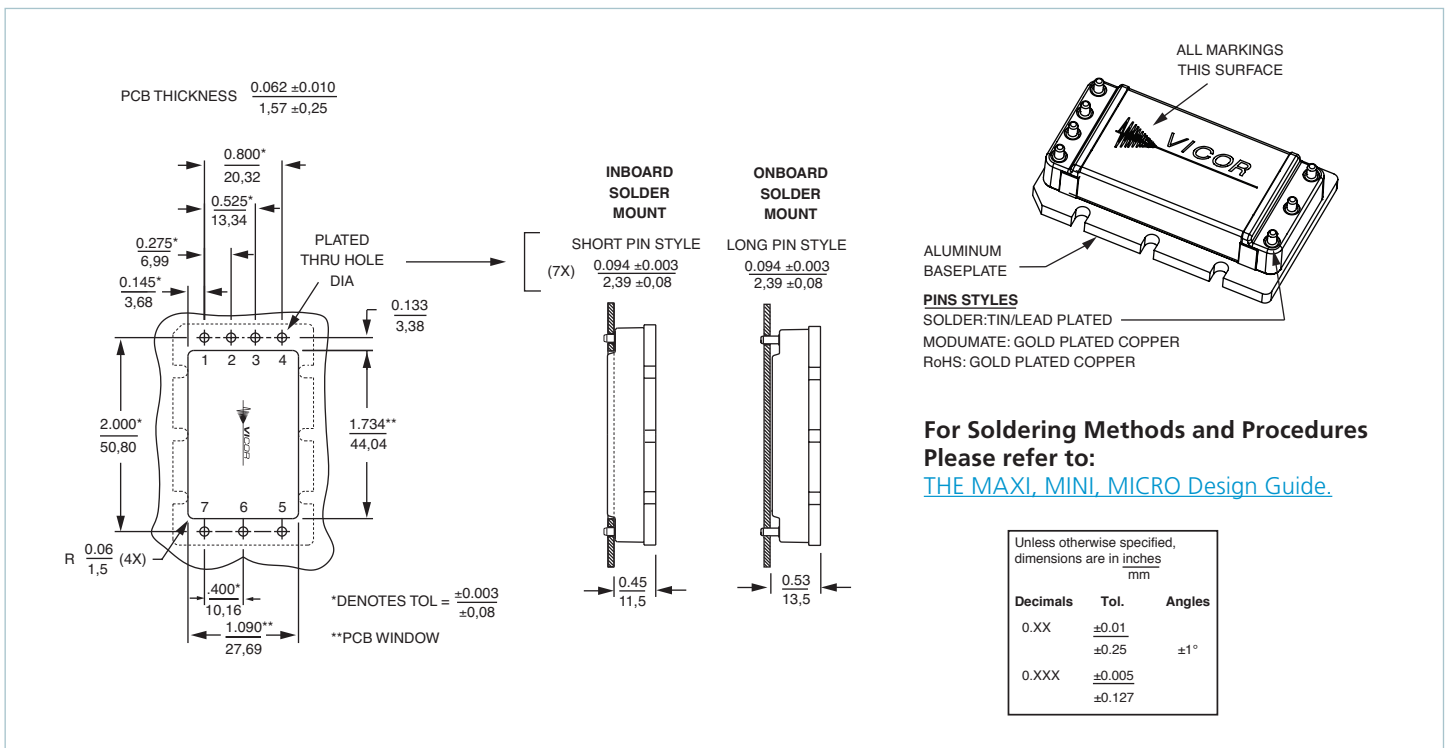

Figure 14 — PCB mounting specifications

Vicor's comprehensive line of power solutions includes high density AC-DC and DC-DC modules and accessory components, fully configurable AC-DC and DC-DC power supplies, and complete custom power systems.

Information furnished by Vicor is believed to be accurate and reliable. However, no responsibility is assumed by Vicor for its use. Vicor makes no representations or warranties with respect to the accuracy or completeness of the contents of this publication. Vicor reserves the right to make changes to any products, specifications, and product descriptions at any time without notice. Information published by Vicor has been checked and is believed to be accurate at the time it was printed; however, Vicor assumes no responsibility for inaccuracies. Testing and other quality controls are used to the extent Vicor deems necessary to support Vicor's product warranty. Except where mandated by government requirements, testing of all parameters of each product is not necessarily performed.

Specifications are subject to change without notice.

Visit <http://www.vicorpower.com/dc-dc-converters-board-mount/high-density-dc-dc-converters> for the latest product information.

Vicor's Standard Terms and Conditions and Product Warranty

All sales are subject to Vicor's Standard Terms and Conditions of Sale, and Product Warranty which are available on Vicor's webpage (<http://www.vicorpower.com/termsconditionswarranty>) or upon request.

Life Support Policy

VICOR'S PRODUCTS ARE NOT AUTHORIZED FOR USE AS CRITICAL COMPONENTS IN LIFE SUPPORT DEVICES OR SYSTEMS WITHOUT THE EXPRESS PRIOR WRITTEN APPROVAL OF THE CHIEF EXECUTIVE OFFICER AND GENERAL COUNSEL OF VICOR CORPORATION. As used herein, life support devices or systems are devices which (a) are intended for surgical implant into the body, or (b) support or sustain life and whose failure to perform when properly used in accordance with instructions for use provided in the labeling can be reasonably expected to result in a significant injury to the user. A critical component is any component in a life support device or system whose failure to perform can be reasonably expected to cause the failure of the life support device or system or to affect its safety or effectiveness. Per Vicor Terms and Conditions of Sale, the user of Vicor products and components in life support applications assumes all risks of such use and indemnifies Vicor against all liability and damages.

Intellectual Property Notice

Vicor and its subsidiaries own Intellectual Property (including issued U.S. and Foreign Patents and pending patent applications) relating to the products described in this data sheet. No license, whether express, implied, or arising by estoppel or otherwise, to any intellectual property rights is granted by this document. Interested parties should contact Vicor's Intellectual Property Department.

Vicor Corporation

25 Frontage Road
Andover, MA, USA 01810
Tel: 800-735-6200
Fax: 978-475-6715

email

Customer Service: custserv@vicorpower.com
Technical Support: apps@vicorpower.com