



Data Sheet

72V Input Mini Family

DC-DC Converter Module



Features

- DC input range: 43 – 110 V (continuous)
- Isolated output
- Encapsulated circuitry for shock and vibration resistance
- Extended temperature range (-55 to +100°C)
- Input surge withstand: 150 V for 100 ms
- DC output: 3.3 – 48 V
- Programmable output: 10 to 110%
- Regulation: ±0.2% no load to full load
- Efficiency: Up to 88%
- Maximum operating temp: 100 °C, full load
- Power density: up to 100 W per cubic inch
- Height above board: 0.43 in. (10,9 mm)
- Parallelable, with N+M fault tolerance
- Low noise ZCS/ZVS architecture
- RoHS Compliant (with F or G pin option)



Shown actual size:
2.28 x 2.2 x 0.5 in
57,9 x 55,9 x 12,7 mm

Product Overview

These DC-DC converter modules use advanced power processing, control and packaging technologies to provide the performance, flexibility, reliability and cost effectiveness of a mature power component. High frequency ZCS/ZVS switching provides high power density with low noise and high efficiency.

Applications

Railway/Transportation system applications including communications systems, information display, lighting, control systems, ticket machines, passenger entertainment, public address systems, door control, industrial power systems and power generation systems.

For details on proper operation please refer to the [Design Guide & Applications Manual for Maxi, Mini, Micro Family](#).

Absolute Maximum Ratings

Parameter	Rating	Unit	Notes
+In to -In voltage	-0.5 to +155	Vdc	
PC to -In voltage	-0.5 to +7.0	Vdc	
PR to -In voltage	-0.5 to +7.0	Vdc	
SC to -Out voltage	-0.5 to +1.5	Vdc	
-Sense to -Out voltage	1.0	Vdc	
Isolation voltage			
in to out	3000	Vrms	Test voltage
in to base	1500	Vrms	Test voltage
out to base	500	Vrms	Test voltage
Operating Temperature	-55 to +100	°C	M-Grade
Storage Temperature	-65 to +125	°C	M-Grade
Pin soldering temperature	500 (260)	°F (°C)	<5 sec; wave solder
	750 (390)	°F (°C)	<7 sec; hand solder
Mounting torque	5 (0.57)	in-lbs (N-m)	6 each

Part Numbering

e.g. V72B24C250BL

V72B [] [] [] B [] []

Output Voltage
3V3 = 3.3 V
5 = 5 V
8 = 8 V
12 = 12 V
15 = 15 V
24 = 24 V
28 = 28 V
36 = 36 V
48 = 48 V

Product Grade Temperatures (°C)		
Grade	Operating	Storage
E	= -10 to +100	-20 to +125
C	= -20 to +100	-40 to +125
T	= -40 to +100	-40 to +125
H	= -40 to +100	-55 to +125
M	= -55 to +100	-65 to +125

Output Power	
Vout	Pout
3.3 V	100 W
5 V	150 W
8 V	150 W
12 V	250 W
15 V	250 W
24 V	250 W
28 V	250 W
36 V	250 W
48 V	250 W

Pin Style	Finish
Blank: Short	Tin/Lead
L: Long	Tin/Lead
S: Short ModuMate	Gold
N: Long ModuMate	Gold
F: Short RoHS	Gold
G: Long RoHS	Gold

Baseplate
Blank: Slotted
2: Threaded
3: Through-hole

MODULE FAMILY ELECTRICAL CHARACTERISTICS

Electrical characteristics apply over the full operating range of input voltage, output load (resistive) and baseplate temperature, unless otherwise specified. All temperatures refer to the operating temperature at the center of the baseplate.

■ MODULE INPUT SPECIFICATIONS

Parameter	Min	Typ	Max	Unit	Notes
Operating input voltage	43	72	110	Vdc	EN50155
Input surge withstand			150	Vdc	<100 ms
Undervoltage turn-on		41.7	42.6	Vdc	
Undervoltage turn-off	35.2	36.5		Vdc	
Overvoltage turn-off/on	111	115.5	121	Vdc	
Disabled input current			1.5	mA	PC pin low

■ MODULE OUTPUT SPECIFICATIONS

Parameter	Min	Typ	Max	Unit	Notes
Output voltage setpoint			±1	% Vout nom.	Nominal input; full load; 25 °C
Line regulation		±0.02	±0.20	%	Low line to high line; full load
Temperature regulation		±0.002	±0.005	% / °C	Over operating temperature range
Power sharing accuracy		±2	±5	%	10 to 100% of full load
Programming range	10		110	%	Of nominal output voltage. For trimming below 90% of nominal, a minimum load of 10% of maximum rated power may be required.
+Out to -Out, +Sense to -Out — Absolute Maximum Ratings					
3.3 V			-0.5 to 4.7	Vdc	Externally applied
5 V			-0.5 to 7.0	Vdc	Externally applied
8 V			-0.5 to 10.9	Vdc	Externally applied
12 V			-0.5 to 16.1	Vdc	Externally applied
15 V			-0.5 to 20.0	Vdc	Externally applied
24 V			-0.5 to 31.7	Vdc	Externally applied
28 V			-0.5 to 36.9	Vdc	Externally applied
36 V			-0.5 to 47.1	Vdc	Externally applied
48 V			-0.5 to 62.9	Vdc	Externally applied

Note: For important information relative to applications where the converter modules are subject to continuous dynamic loading, contact Vicor applications engineering at 800-927-9474.

■ THERMAL RESISTANCE AND CAPACITY

Parameter	Min	Typ	Max	Unit
Baseplate to sink; flat, greased surface		0.16		°C/Watt
Baseplate to sink; thermal pad (P/N 20264)		0.14		°C/Watt
Baseplate to ambient		8.0		°C/Watt
Baseplate to ambient; 1000 LFM		1.9		°C/Watt
Thermal capacity		83		Watt-sec/°C

MODULE FAMILY ELECTRICAL CHARACTERISTICS (CONT.)

■ MODULE CONTROL SPECIFICATIONS

Parameter	Min	Typ	Max	Unit	Notes
PRIMARY SIDE (PC = Primary Control; PR = Parallel)					
PC bias voltage	5.50	5.75	6.00	Vdc	PC current = 1.0 mA PC voltage = 5.5 V During normal operation
current limit	1.5	2.1	3.0	mA	
PC module disable	2.3	2.6	2.9	Vdc	Switch must be able to sink ≥ 4 mA. See Fig. 2
PC module enable delay		4	7	ms	
PC module alarm			0.5	Vavg	UV, OV, OT, module fault. See Figs. 3 and 5
PC resistance	0.9	1.0	1.1	M Ω	See Fig. 3, converter off or fault mode
PR emitter amplitude	5.7	5.9	6.1	Volts	PR load $>30 \Omega$, <30 pF
PR emitter current	150			mA	
PR receiver impedance	375	500	625	Ω	25 °C
PR receiver threshold	2.4	2.5	2.6	Volts	Minimum pulse width: 20 ns
PR drive capability			12	modules	Without PR buffer amplifier
SECONDARY SIDE (SC = Secondary Control)					
SC bandgap voltage	1.21	1.23	1.25	Vdc	Referenced to –Sense
SC resistance	990	1000	1010	Ω	
SC capacitance		0.033		μ F	
SC module alarm		0		Vdc	With open trim; referenced to –Sense. See Fig. 7

■ MODULE GENERAL SPECIFICATIONS

Parameter	Min	Typ	Max	Unit	Notes
Remote sense (total drop)			0.5	Vdc	0.25 V per leg (sense leads must be connected to respective, output terminals)
Isolation test voltage (in to out)*	3000			Vrms	Complies with reinforced insulation requirements
Isolation test voltage (in to base)*	1500			Vrms	Complies with basic insulation requirements
Isolation test voltage (out to base)*	500			Vrms	Complies with operational insulation requirements
Isolation resistance		10		M Ω	in to out, in to baseplate, out to baseplate
Weight (E, C, T grade)	3.1 (89.3)	3.5 (100.3)	3.9 (111.3)	ounces (grams)	
Weight (H, M grade)	3.5 (99.6)	3.9 (110.6)	4.3 (121.6)	ounces (grams)	
Temperature limiting	100	115		°C	See Figs. 3 and 5. Do not operate coverter >100 C.
Agency approvals		cURus, cTÜVus, CE			UL60950-1, EN60950-1, CSA60950-1, IEC60950-1. With appropriate fuse in series with the +Input

* Isolation test voltage, 1 minute or less.

Note:

Specifications are subject to change without notice.

■ MODULE SPECIFIC OPERATING SPECIFICATIONS

3.3 Vout, 100 W (e.g. V72B3V3C100BL)

Parameter	Min	Typ	Max	Unit	Notes
Efficiency	80	82.2		%	Nominal input; full load; 25 °C
Ripple and noise		185	232	mV	p-p; Nominal input; full load; 20 MHz bandwidth
Output OVP setpoint	4.14	4.3	4.46	Volts	25 °C; recycle input voltage or PC to restart (>100 ms off)
Dissipation, standby		4.4	5.4	Watts	No load
Load regulation		±0.02	±0.2	%	No load to full load; nominal input
Output Current	0		30.3	Amps	
Current limit	30.9	34.8	41	Amps	Output voltage 95% of nominal
Short circuit current	21.2	34.8	41	Amps	Output voltage <250 mV

5 Vout, 150 W (e.g. V72B5C150BL)

Parameter	Min	Typ	Max	Unit	Notes
Efficiency	84	85		%	Nominal input; full load; 25 °C
Ripple and noise		120	150	mV	p-p; Nominal input; full load; 20 MHz bandwidth
Output OVP setpoint	6.03	6.25	6.47	Volts	25 °C; recycle input voltage or PC to restart (>100 ms off)
Dissipation, standby		7.9	8.6	Watts	No load
Load regulation		±0.02	±0.2	%	No load to full load; nominal input
Output Current	0		30	Amps	
Current limit	30.6	34.5	40.5	Amps	Output voltage 95% of nominal
Short circuit current	21	34.5	40.5	Amps	Output voltage <250 mV

8 Vout, 150 W (e.g. V72B8C150BL)

Parameter	Min	Typ	Max	Unit	Notes
Efficiency	83.5	84.5		%	Nominal input; full load; 25 °C
Ripple and noise		220	275	mV	p-p; Nominal input; full load; 20 MHz bandwidth
Output OVP setpoint	9.36	9.7	10.1	Volts	25 °C; recycle input voltage or PC to restart (>100 ms off)
Dissipation, standby		5.9	6.9	Watts	No load
Load regulation		±0.02	±0.2	%	No load to full load; nominal input
Output Current	0		18.75	Amps	
Current limit	19.1	21.6	25.4	Amps	Output voltage 95% of nominal
Short circuit current	5	21.6	25.4	Amps	Output voltage <250 mV

12 Vout, 250 W (e.g. V72B12C250BL)

Parameter	Min	Typ	Max	Unit	Notes
Efficiency	85	86.5		%	Nominal input; full load; 25 °C
Ripple and noise		300	375	mV	p-p; Nominal input; full load; 20 MHz bandwidth
Output OVP setpoint	13.7	14.3	14.9	Volts	25 °C; recycle input voltage or PC to restart (>100 ms off)
Dissipation, standby		8.5	9.5	Watts	No load
Load regulation		±0.02	±0.2	%	No load to full load; nominal input
Output Current	0		20.83	Amps	
Current limit	21.2	23.9	28.2	Amps	Output voltage 95% of nominal
Short circuit current	14.5	23.9	28.1	Amps	Output voltage <250 mV

15 Vout, 250 W (e.g. V72B15C250BL)

Parameter	Min	Typ	Max	Unit	Notes
Efficiency	85.1	86.3		%	Nominal input; full load; 25 °C
Ripple and noise		400	500	mV	p-p; Nominal input; full load; 20 MHz bandwidth
Output OVP setpoint	17.1	17.8	18.5	Volts	25 °C; recycle input voltage or PC to restart (>100 ms off)
Dissipation, standby		8.3	8.8	Watts	No load
Load regulation		±0.02	±0.2	%	No load to full load; nominal input
Output Current	0		16.67	Amps	
Current limit	17	19.2	22.6	Amps	Output voltage 95% of nominal
Short circuit current	11.6	19.2	22.6	Amps	Output voltage <250 mV

■ MODULE SPECIFIC OPERATING SPECIFICATIONS (CONT.)

24 Vout, 250 W (e.g. V72B24C250BL)

Parameter	Min	Typ	Max	Unit	Notes
Efficiency	85.5	86.8		%	Nominal input; full load; 25 °C
Ripple and noise		216	270	mV	p-p; Nominal input; full load; 20 MHz bandwidth
Output OVP setpoint	27.1	28.1	29.1	Volts	25 °C; recycle input voltage or PC to restart (>100 ms off)
Dissipation, standby		7.8	8.9	Watts	No load
Load regulation		±0.02	±0.2	%	No load to full load; nominal input
Output Current	0		10.42	Amps	
Current limit	10.6	12	14.1	Amps	Output voltage 95% of nominal
Short circuit current	7.28	12	14.1	Amps	Output voltage <250 mV

28 Vout, 250 W (e.g. V72B28C250BL)

Parameter	Min	Typ	Max	Unit	Notes
Efficiency	86.5	88		%	Nominal input; full load; 25 °C
Ripple and noise		270	338	mV	p-p; Nominal input; full load; 20 MHz bandwidth
Output OVP setpoint	31.5	32.7	33.9	Volts	25 °C; recycle input voltage or PC to restart (>100 ms off)
Dissipation, standby		7.7	8.2	Watts	No load
Load regulation		±0.02	±0.2	%	No load to full load; nominal input
Output Current	0		8.93	Amps	
Current limit	9.1	10.3	12.1	Amps	Output voltage 95% of nominal
Short circuit current	6.25	10.3	12.1	Amps	Output voltage <250 mV

36 Vout, 250 W (e.g. V72B36C250BL)

Parameter	Min	Typ	Max	Unit	Notes
Efficiency	86.5	87.7		%	Nominal input; full load; 25 °C
Ripple and noise		200	250	mV	p-p; Nominal input; full load; 20 MHz bandwidth
Output OVP setpoint	40.4	41.9	43.4	Volts	25 °C; recycle input voltage or PC to restart (>100 ms off)
Dissipation, standby		10.1	11	Watts	No load
Load regulation		±0.02	±0.2	%	No load to full load; nominal input
Output Current	0		6.94	Amps	
Current limit	7.07	7.98	9.37	Amps	Output voltage 95% of nominal
Short circuit current	4.85	7.98	9.37	Amps	Output voltage <250 mV

48 Vout, 250 W (e.g. V72B48C250BL)

Parameter	Min	Typ	Max	Unit	Notes
Efficiency	85.5	87.0		%	Nominal input; full load; 25 °C
Ripple and noise		202	253	mV	p-p; Nominal input; full load; 20 MHz bandwidth
Output OVP setpoint	53.7	55.7	57.7	Volts	25 °C; recycle input voltage or PC to restart (>100 ms off)
Dissipation, standby		8.7	10.5	Watts	No load
Load regulation		±0.02	±0.2	%	No load to full load; nominal input
Output Current	0		5.21	Amps	
Current limit	5.31	5.99	7.04	Amps	Output voltage 95% of nominal
Short circuit current	3.64	5.99	7.04	Amps	Output voltage <250 mV

BASIC MODULE OPERATION

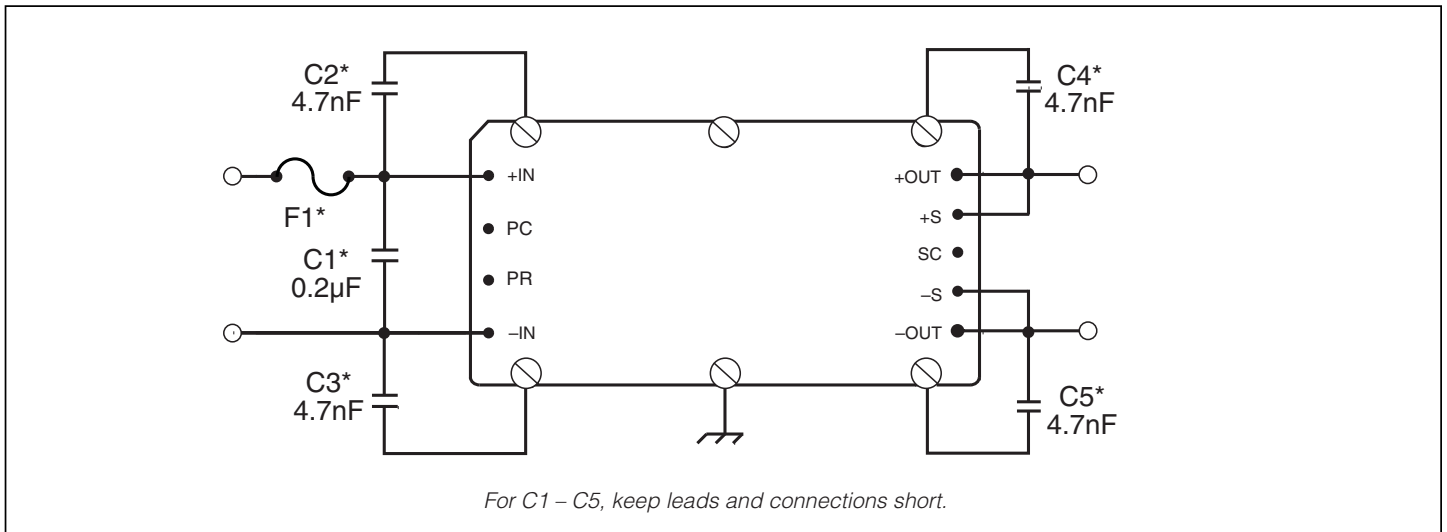

Figure 1 — Basic module operation requires fusing, grounding, bypassing capacitors.

* See Maxi, Mini, Micro Design Guide.

Comprehensive Online Application Information



The Design Guide and Applications Manual includes:

- Application circuits
 - Design requirements
 - EMC considerations
 - Current sharing in power arrays
 - Thermal performance information
 - Recommended soldering methods
 - Accessory modules – filtering, rectification, front-ends
 - Mounting options
- ...and more.

[CLICK HERE TO VIEW DESIGN GUIDE](#)

Also at vicorpower.com

- PowerBench online configurators
- Over 20 Application Notes
- Online calculators – thermal, trimming, hold-up
- PDF data sheets for ALL Vicor products

PRIMARY CONTROL - PC PIN

Module Enable/Disable

The module may be disabled by pulling PC to 0 V (2.3 V max) with respect to the -Input. This may be done with an open collector transistor, relay, or optocoupler. Converters may be disabled with a single transistor or relay either directly or via "OR'ing" diodes for 2 or more converters. See Figure 2.

Primary Auxiliary Supply

During normal operation only, the PC Pin can source 5.7 V @ 1.5 mA. In the example shown in Figure 4, PC powers a module enabled LED.

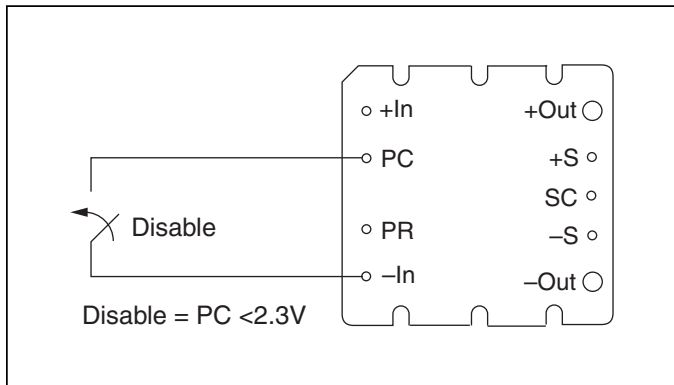

Figure 2 — Module enable/disable.

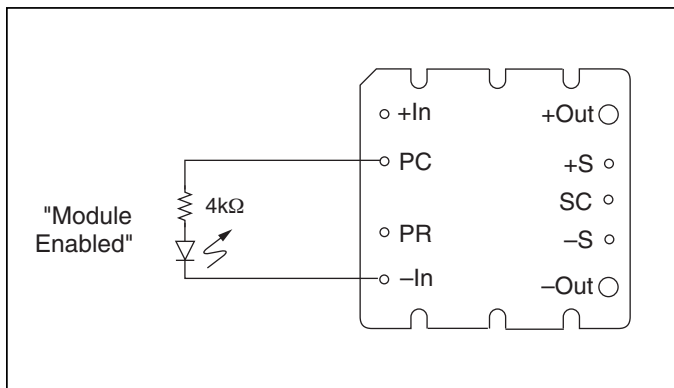

Figure 4 — LED on-state indicator.

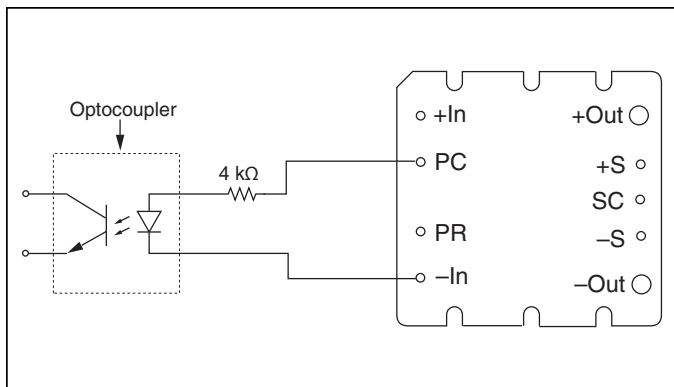

Figure 6 — Isolated on-state indicator.

Module Alarm

The module contains "watchdog" circuitry which monitors input voltage, operating temperature and internal operating parameters. In the event that any of these parameters are outside of their allowable operating range, the module will shut down and PC will go low. PC will periodically go high and the module will check to see if the fault (as an example, Input Undervoltage) has cleared. If the fault has not been cleared, PC will go low again and the cycle will restart. The SC pin will go low in the event of a fault and return to its normal state after the fault has been cleared. See Figures 3 and 5.

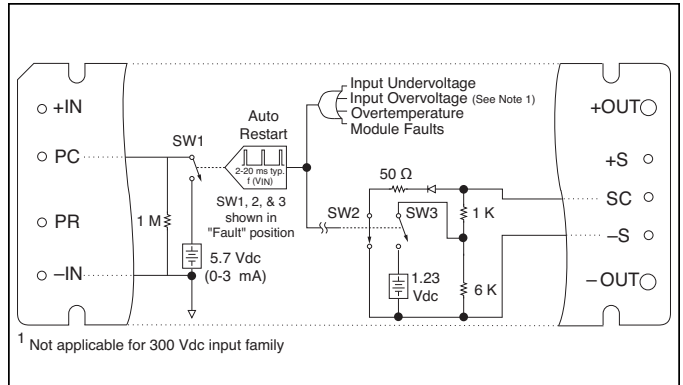

Figure 3 — PC/SC module alarm logic.

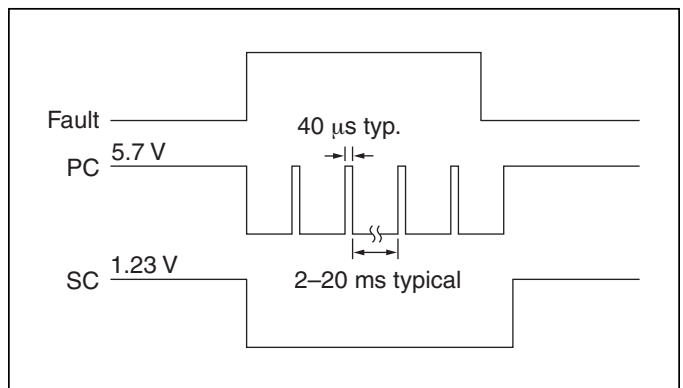

Figure 5 — PC/SC module alarm timing.

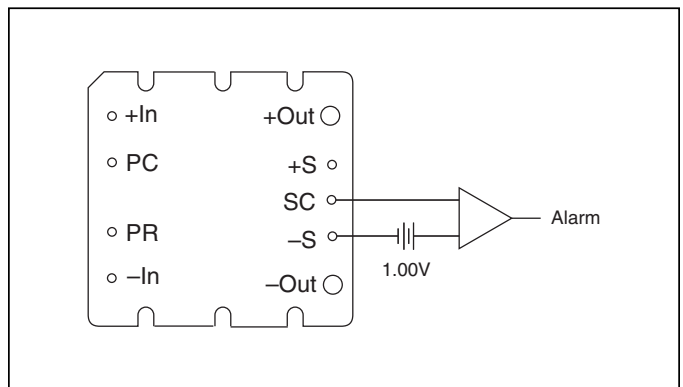

Figure 7 — Secondary side on-state indicator.

SECONDARY CONTROL - SC PIN

Output Voltage Programming

The output voltage of the converter can be adjusted or programmed via fixed resistors, potentiometers or voltage DACs. See Figure 8.

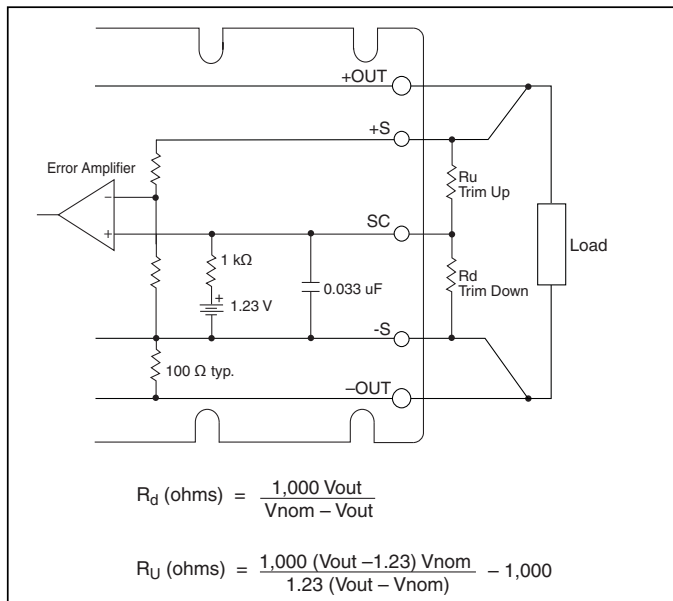

Figure 8 — Output voltage trim down and trim up circuit.

Trim Down

1. This converter is not a constant power device – it has a constant current limit. Hence, available output power is reduced by the same percentage that output voltage is trimmed down. Do not exceed maximum rated output current.
2. The trim down resistor must be connected between the SC and -S pins. Do not bypass the SC pin directly with a capacitor.

Trim Up

1. The converter is rated for a maximum delivered power. To ensure that maximum rated power is not exceeded, reduce maximum output current by the same percentage increase in output voltage.
2. The trim up resistor must be connected between the SC and +S pins. Do not bypass the SC pin directly with a capacitor.
3. Do not trim the converter above maximum trim range (typically +10%) or the output over voltage protection circuitry may be activated.

Trim resistor values calculated automatically:

On-line calculators for trim resistor values are available on the vicor website at:

asp.vicorpower.com/calculators/calculators.asp?calc=1

Resistor values can be calculated for fixed trim up, fixed trim down and for variable trim up or down.

PARALLEL BUS - PR PIN

Parallel Operation

The PR pin supports paralleling for increased power with N+1 (N+M) redundancy. Modules of the same input voltage, output voltage, and power level will current share if all PR pins are suitably interfaced.

Compatible interface architectures include the following:

AC coupled single-wire interface. All PR pins are connected to a single communication bus through 0.001 μF (500 V) capacitors. This interface supports current sharing and is fault tolerant except for the communication bus. Up to three converters may be paralleled by this method. See Figure 9.

Transformer coupled interface. For paralleling four or more converters a transformer coupled interface is required. See Figure 10.

For details on parallel operation please refer to the

[Design Guide & Applications Manual for Maxi, Mini, Micro Family.](#)

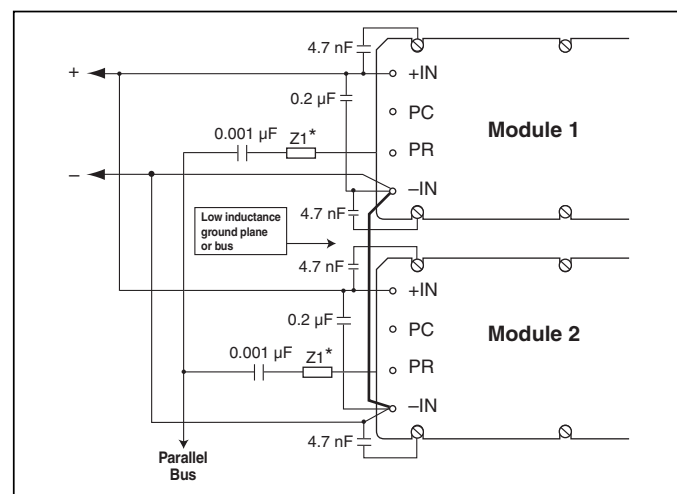

Figure 9 — AC coupled single-wire interface.

* See Maxi, Mini, Micro Design Guide.

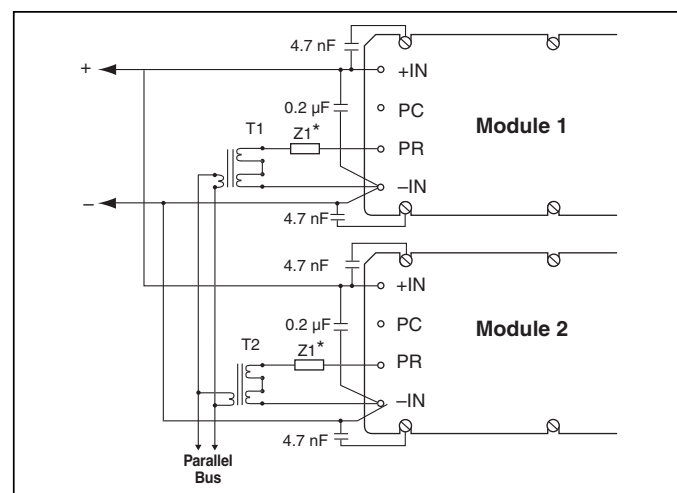

Figure 10 — Transformer-coupled interface.

PARALLEL BUS OUTPUT

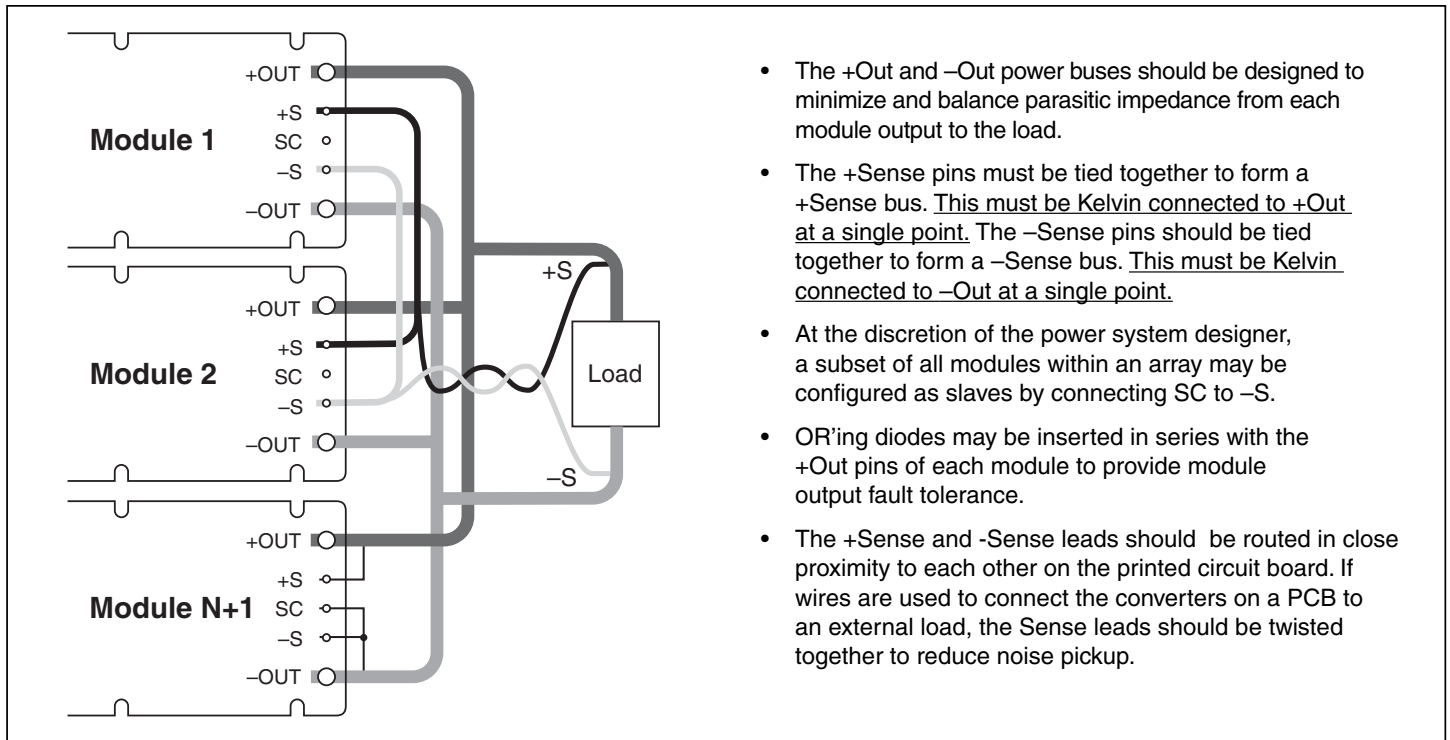

Figure 11 — N+1 module array output connections.

■ PIN STYLES*

Designator	Description	Finish	Notes
(None)	Short	Tin/Lead	Requires in-board, mounting
L	Long	Tin/Lead	On-board mounting for 0.065" boards
S	Short ModuMate	Gold	SurfMate or in-board socket mounting
N	Long ModuMate	Gold	On-board socket mounting
F	Short RoHS	Gold	Select for RoHS compliant in-board solder, socket, or SurfMate mounting
G	Long RoHS	Gold	Select for RoHS compliant on-board solder or socket mounting

* Pin style designator follows the “B” after the output power and precedes the baseplate designator.
Ex. V72B12T250BN2 — Long ModuMate Pins

MECHANICAL DRAWINGS

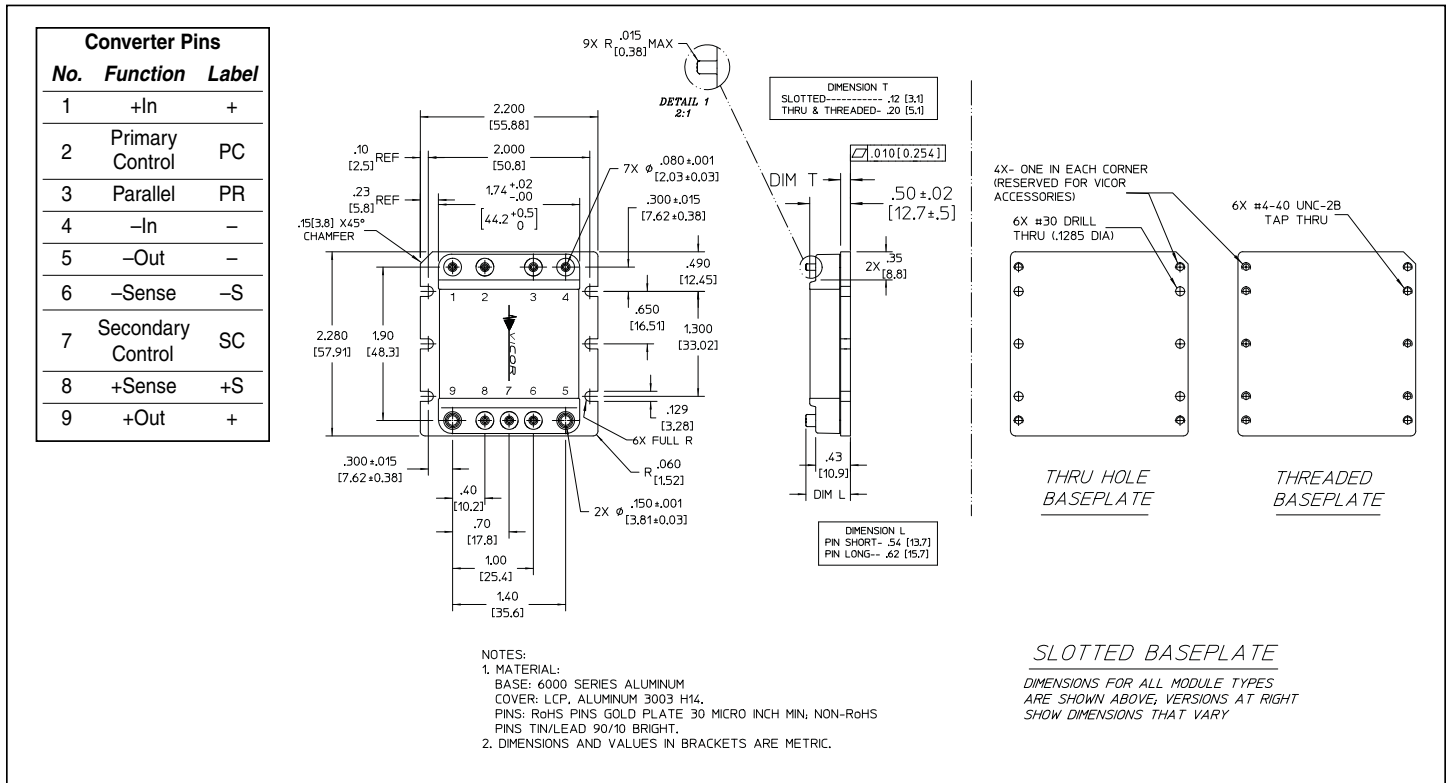

Figure 12 — Module outline

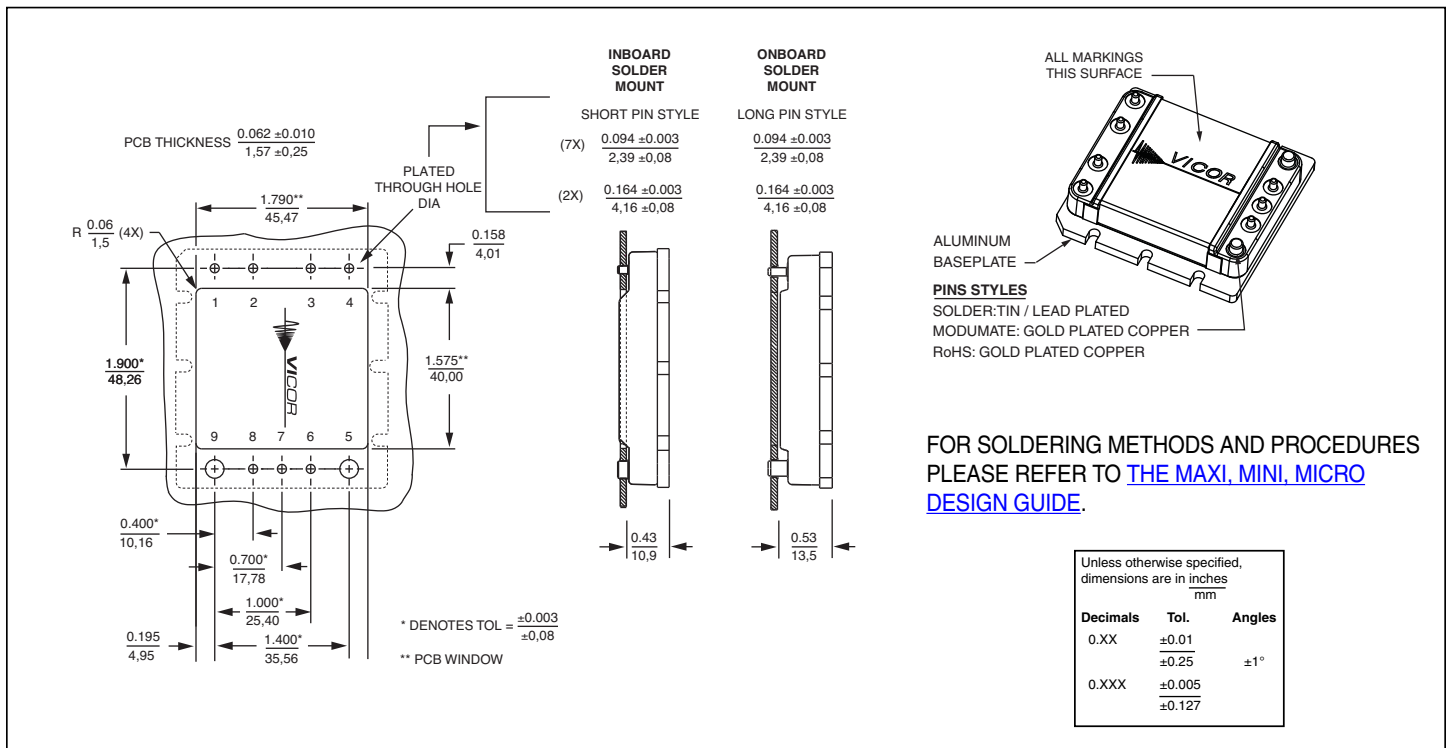

Figure 13 — PCB mounting specifications

Warranty

Vicor products are guaranteed for two years from date of shipment against defects in material or workmanship when in normal use and service. This warranty does not extend to products subjected to misuse, accident, or improper application or maintenance. Vicor shall not be liable for collateral or consequential damage. This warranty is extended to the original purchaser only.

EXCEPT FOR THE FOREGOING EXPRESS WARRANTY, VICOR MAKES NO WARRANTY, EXPRESS OR IMPLIED, INCLUDING, BUT NOT LIMITED TO, THE WARRANTY OF MERCHANTABILITY OR FITNESS FOR A PARTICULAR PURPOSE.

Vicor will repair or replace defective products in accordance with its own best judgement. For service under this warranty, the buyer must contact Vicor to obtain a Return Material Authorization (RMA) number and shipping instructions. Products returned without prior authorization will be returned to the buyer. The buyer will pay all charges incurred in returning the product to the factory. Vicor will pay all reshipment charges if the product was defective within the terms of this warranty.

Information published by Vicor has been carefully checked and is believed to be accurate; however, no responsibility is assumed for inaccuracies. Vicor reserves the right to make changes to any products without further notice to improve reliability, function, or design. Vicor does not assume any liability arising out of the application or use of any product or circuit; neither does it convey any license under its patent rights nor the rights of others. Vicor general policy does not recommend the use of its components in life support applications wherein a failure or malfunction may directly threaten life or injury. Per Vicor Terms and Conditions of Sale, the user of Vicor components in life support applications assumes all risks of such use and indemnifies Vicor against all damages.

Vicor's comprehensive line of power solutions includes high density AC-DC and DC-DC modules and accessory components, fully configurable AC-DC and DC-DC power supplies, and complete custom power systems.

Information furnished by Vicor is believed to be accurate and reliable. However, no responsibility is assumed by Vicor for its use. Vicor components are not designed to be used in applications, such as life support systems, wherein a failure or malfunction could result in injury or death. All sales are subject to Vicor's Terms and Conditions of Sale, which are available upon request.

Specifications are subject to change without notice.

Intellectual Property Notice

Vicor and its subsidiaries own Intellectual Property (including issued U.S. and Foreign Patents and pending patent applications) relating to the products described in this data sheet. Interested parties should contact Vicor's Intellectual Property Department.

Vicor Corporation
25 Frontage Road
Andover, MA, USA 01810
Tel: 800-735-6200
Fax: 978-475-6715

email

Customer Service: custserv@vicorpower.com
Technical Support: apps@vicorpower.com