



# Data Sheet

## 110 V FIAM™

### Filter Input Attenuator Module

#### Features

- RoHS Compliant (with F or G pin style)
- EMI filtering-EN50121-3-2\*
- Transient protection-EN50155, EN50121-3-2
- Low profile mounting options
- 500 W output power
- 60950-1 compliance
- Mini-size package
- Inrush current limiting

#### Product Highlights

The FIAM110 is a DC front-end module designed for rail applications providing transient protection, inrush current limiting and EMI filtering (EN50121-3-2) in a Mini-size package. The FIAM enables designers using Vicor 110 Vin Mini, Micro, or Maxi or VI/VE-200 and VI/VE-J00 (T input) DC-DC converters to meet the transient immunity and EMI requirements required for the rail industry and protect system hardware from inrush current. The FIAM110 accepts an input voltage of 66 – 154 Vdc and provide up to 500 W of output power and remote on/off control.

The FIAM110 is housed in an industry standard "half brick" module measuring 2.28" x 2.2" x 0.5" and depending upon model selected, may be mounted on-board or in-board for height critical applications.

#### Compatible Products

- Mini, Micro, Maxi 110 V Input DC-DC converters
- VI / VE-200, VI / VE-J00 ("T" input)

\*EMI performance is subject to a wide variety of external influences such as PCB construction, circuit layout etc. As such, external components in addition to those listed herein may be required in specific instances to gain full compliance to the standards specified.



Shown actual size:  
2.28 x 2.2 x 0.5 in  
57,9 x 55,9 x 12,7 mm

#### Absolute Maximum Rating

Parameter	Rating	Unit	Notes
+In to -In	154	Vdc	Continuous
	385	V	20 ms
+Out to -Out	154	Vdc	Continuous
Mounting torque	5(0.57)	in-lbs	6 each, #4-40 or M3
Operating temperature	- 55 to +100	°C	M -Grade
Storage temperature	- 65 to +125	°C	M -Grade
Pin soldering temperature	500 (260)	°F(°C)	<5 sec; wave solder
	750 (390)	°F(°C)	<7 sec; hand solder

#### Thermal Resistance

Parameter	Min	Typ	Max	Unit
Baseplate to sink flat, greased surface		0.16		°C/Watt
		0.14		°C/Watt
Baseplate to ambient Free Convection		8.0		°C/Watt
		1.9		°C/Watt

#### Part Numbering

<b>FIAM</b>	<b>110</b>	<b>C</b>	<b>1</b>	<b>1</b>
Product	110 Vin Nominal	Product Grade Temperatures (°C)	Pin Style	Baseplate
		Grade Operating Storage	1 = Short	1 = Slotted
		E = -10 to +100 -20 to 125	2 = Long	2 = Threaded
		C = -20 to +100 -40 to 125	S = Short ModuMate	3 = Thru-hole
		T = -40 to +100 -40 to 125	N = Long ModuMate	
		H = -40 to +100 -55 to 125	F = Short RoHS	
		M = -55 to +100 -65 to 125	G = Long RoHS	

## Specifications

(typical at  $T_{BP} = 25\text{ }^{\circ}\text{C}$ , nominal line and 75% load, unless otherwise specified)

### INPUT SPECIFICATIONS

Parameter	Min	Typ	Max	Unit	Notes
Input voltage	66	110	154	Vdc	Continuous
Inrush limiting			0.06	A/ $\mu\text{F}$	
Transient immunity			176	Vdc	Consistent with 100 ms per NF F 01-510
			165	Vdc	Consistent with 1 s per RIA 12
			385	Vdc	Consistent with 20 ms per RIA 12

### OUTPUT SPECIFICATIONS

Parameter	Min	Typ	Max	Unit	Notes
Output power			500	W	Output power derates linearly below 77 Vin to 400 W @ 66 Vin
Efficiency		98		%	
Internal Voltage Drop			2.5	V	500 W at 25 $^{\circ}\text{C}$ baseplate
External capacitance			100	$\mu\text{F}$	

### CONTROL PIN SPECIFICATIONS

Parameter	Min	Typ	Max	Unit	Notes
ON / OFF control					
Enable (ON)	0.0		1.0		Referenced to $-V_{out}$
Disable (OFF)	3.5		5.0	Vdc	100k $\Omega$ internal pull-up resistor

### EMI

Standard	Notes
EN50121-3-2	150 kHz to 500 kHz - 99 dB $\mu\text{V}$ quasi-peak 500 kHz to 30 MHz - 93 dB $\mu\text{V}$ quasi-peak

EMI performance is subject to a wide variety of external influences such as PCB construction, circuit layout etc. As such, external components in addition to those listed herein may be required in specific instances to gain full compliance to the standards specified.

### IMMUNITY

Parameter	Typ. Value	Units	Notes
EN50121-3-2 (Table 7.3 Surges)	$\pm 2,000$	Vdc	Waveform – 1.2 / 50 $\mu\text{s}$ , 42 $\Omega$ , 0.5 $\mu\text{F}$ , line to ground
	$\pm 1,000$	Vdc	Waveform – 1.2 / 50 $\mu\text{s}$ , 42 $\Omega$ , 0.5 $\mu\text{F}$ , line to line
EN50121-3-2 (Table 7.2 Fast Transients)	$\pm 2,000$	Vdc	5/50 ns, 5 kHz Performance Criteria B - no damage to the product but a temporary change in the intended DC voltage is acceptable as long as it self-recovers without user intervention.
EN50121-3-2 (Table 7.1 RF Common Mode)			0.15 to 80 MHz, 10 Vrms, 80% AM, 1 kHz Performance Criteria A - no damage to the product and no change to the intended DC voltage level greater than $\pm 5\%$ .

### SAFETY SPECIFICATIONS

Parameter	Min	Typ	Max	Unit	Notes
Dielectric withstand (I/O to baseplate)		1,000		V <sub>RMS</sub>	
		1,414		Vdc	

## Specifications (Cont.)

### ■ AGENCY APPROVALS

Safety Standards	Markings	Notes
UL60950-1, CSA60950-1, EN60950-1, IEC 60950-1 EN60950-1	cTUVus CE	Pending Low Voltage Directive

### ■ GENERAL SPECIFICATIONS

Parameter	Min	Typ	Max	Unit	Remarks
Weight		3.1 (88)	4 (113)	ounces (grams)	
Warranty			2	years	

### ■ MODULE ENVIRONMENTAL QUALIFICATION

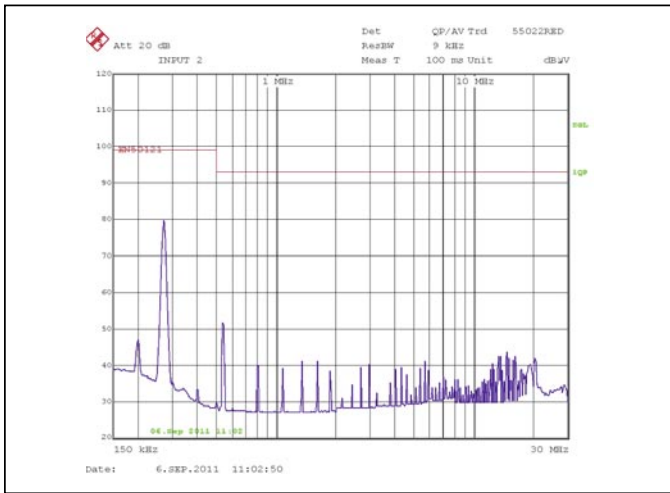
<b>Altitude</b> MIL-STD-810F, Method 500.4, Procedure I & II, 40,000 ft. and 70,000 ft. Operational.
<b>Explosive Atmosphere</b> MIL-STD-810F, Method 511.4, Procedure I, Operational.
<b>Vibration</b> EN 61373, Random Vibration: Category <0.3Kg, Freq range: 5-150Hz @ 5grms, 5hrs per axis. MIL-STD-810F, Method 514.5, Procedure I, Category 14, Sine and Random vibration per Table 514.5C for Helicopter AH-6J Main Rotor with overall level of 5.6 G rms for 4 hours per axis. MIL-STD-810F, Method 514.5C, General Minimum Integrity Curve per Figure 514.5C-17 with overall level of 7.7 G rms for 1 hour per axis.
<b>Shock</b> EN 61373, Shock: Long. / Trans. / Vert. Axis, peak acceleration: 5g / 2g / 1g, Duration: 50 ms/ 20 ms. MIL-STD-810F, Method 516.5, Procedure I, Functional Shock, 40 g. MIL-S-901D, Lightweight Hammer Shock, 3 impacts/axis, 1,3,5 ft. MIL-STD-202F, Method 213B, 60 g, 9 ms half sine. MIL-STD-202F, Method 213B, 75 g, 11 ms Saw Tooth Shock.
<b>Acceleration</b> MIL-STD-810F, Method 513.5, Procedure II, table 513.5-II, Operational, 2-7 g, 6 directions.
<b>Humidity</b> MIL-STD-810F, Method 507.4.
<b>Solder Test</b> MIL-STD-202G, Method 208H, 8 hour aging.

### ■ MODULE ENVIRONMENTAL STRESS SCREENING

Parameter	H-Grade	M-Grade
Operating temperature	-40 °C to +100 °C	-55 °C to +100 °C
Storage temperature	-55 °C to +125 °C	-65 °C to +125 °C
Temperature cycling*	12 cycles -65 °C to +100 °C	12 cycles -65 °C to +100 °C
Ambient test @ 25°C	Yes	Yes
Power cycling burn-in	12 hours, 29 cycles	24 hours, 58 cycles
Functional and parametric ATE tests	-40 °C and +100 °C	-55 °C and +100 °C
Hi-Pot test	Yes	Yes
Visual inspection	Yes	Yes
Test data	<a href="http://vicorpower.com">vicorpower.com</a>	<a href="http://vicorpower.com">vicorpower.com</a>

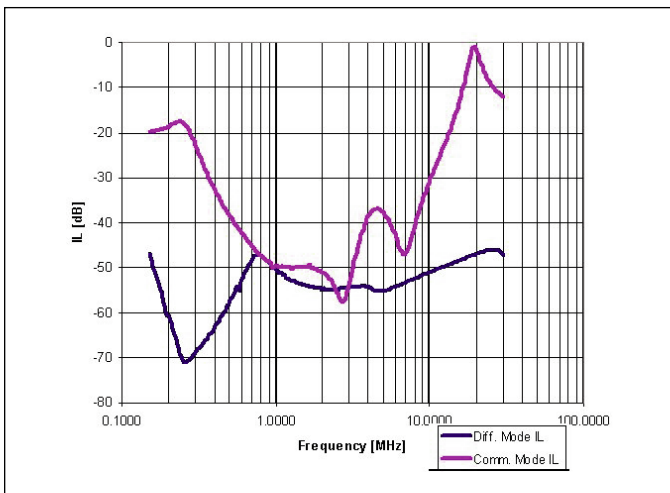
\*Temperature cycled with power off, 17°C per minute rate of change.

## Conducted Noise



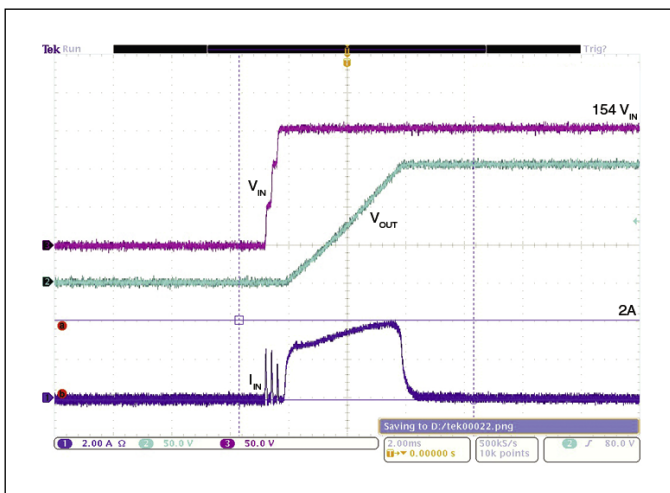
**Figure 1** — Conducted Noise (EN50121-3-2); FIAM110M21 and model V110A24C400BG DC-DC converter operating at 110 Vdc, 375 W.

## Insertion Loss

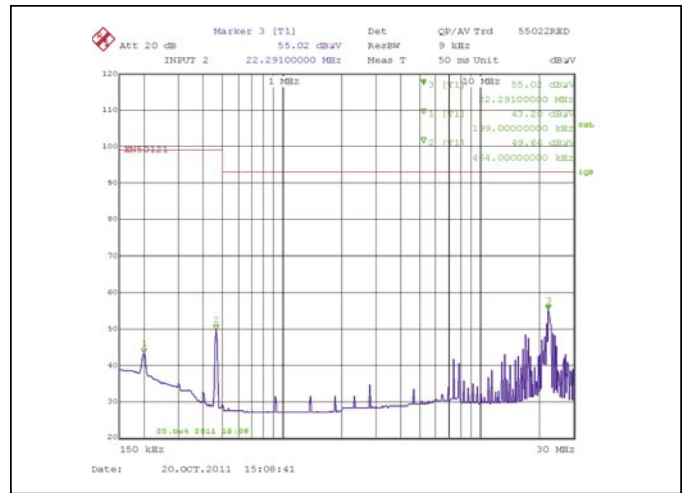


**Figure 3** — Insertion loss curve.

## Inrush Limiting

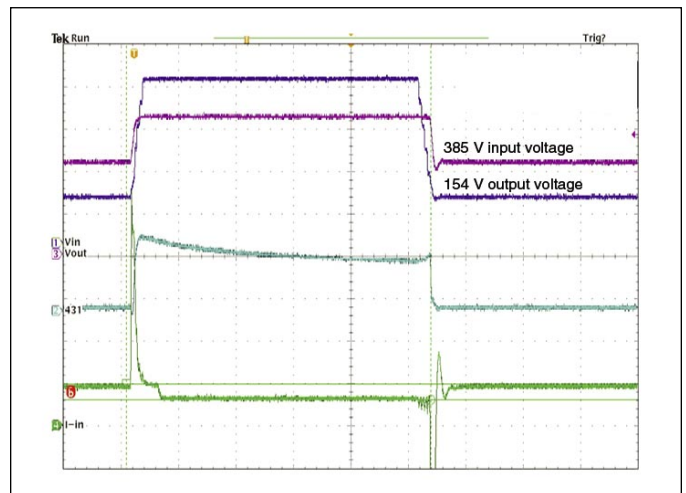


**Figure 5** — Inrush current. (100  $\mu$ F external capacitance)



**Figure 2** — Conducted Noise (EN50121-3-2); FIAM110M21 and model VE-2T3-EW + (3) VI-BT3-IW DC-DC converters operating at 110 Vdc, 375 W.

## Transient Immunity



**Figure 4** — Transient Immunity: FIAM output response to an input transient.

# Transient and Surge Protection

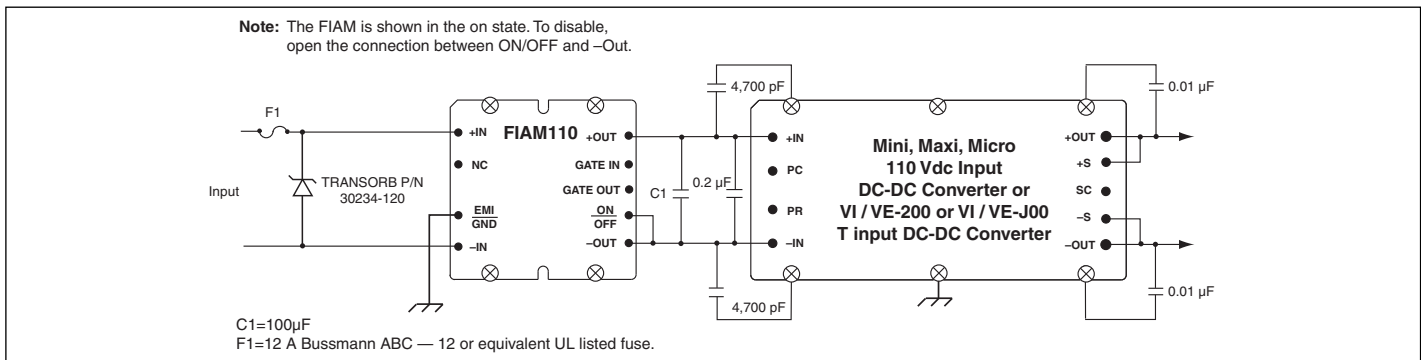
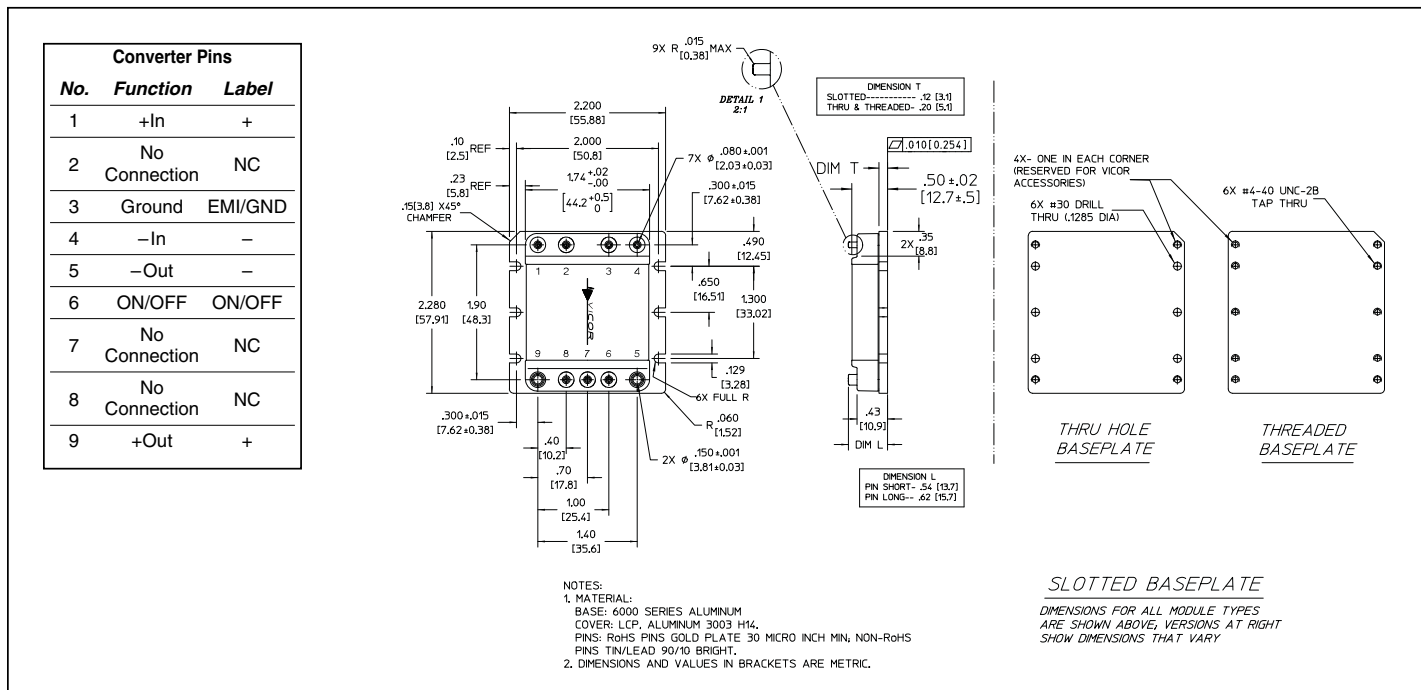
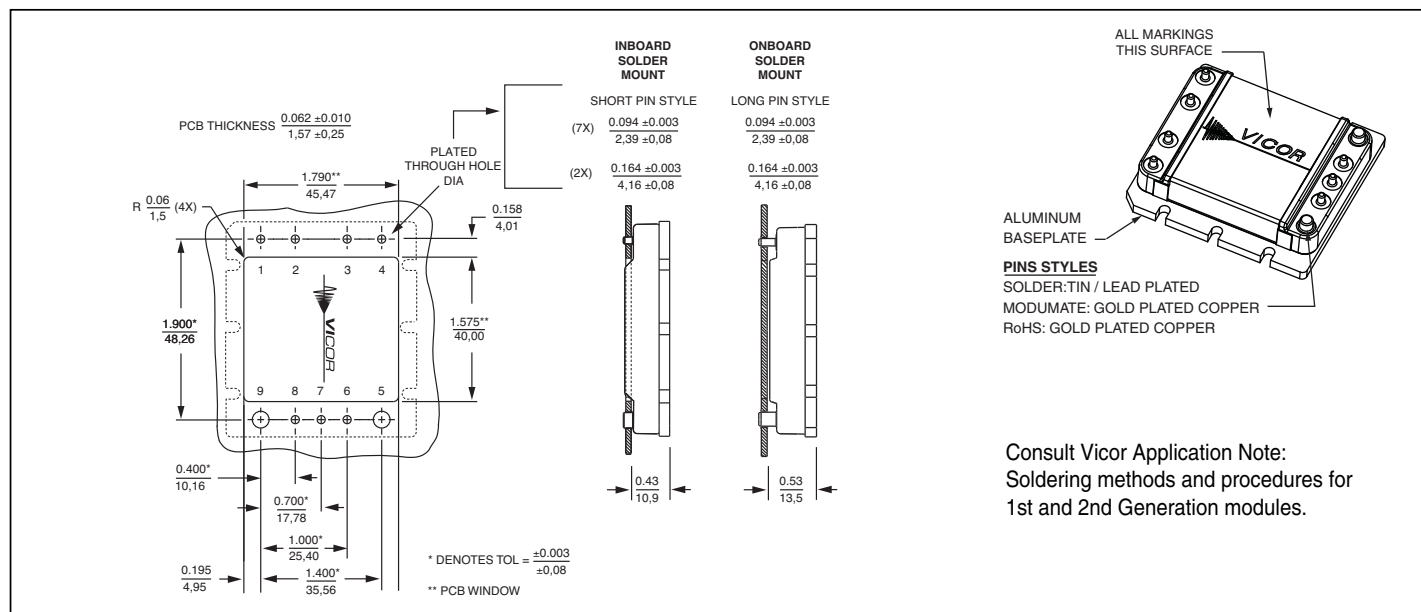


Figure 6 — Typical connection diagram

## Mechanical Diagram



## PCB Mounting Specifications



## **Warranty**

Vicor products are guaranteed for two years from date of shipment against defects in material or workmanship when in normal use and service. This warranty does not extend to products subjected to misuse, accident, or improper application or maintenance. Vicor shall not be liable for collateral or consequential damage. This warranty is extended to the original purchaser only.

EXCEPT FOR THE FOREGOING EXPRESS WARRANTY, VICOR MAKES NO WARRANTY, EXPRESS OR IMPLIED, INCLUDING, BUT NOT LIMITED TO, THE WARRANTY OF MERCHANTABILITY OR FITNESS FOR A PARTICULAR PURPOSE.

Vicor will repair or replace defective products in accordance with its own best judgement. For service under this warranty, the buyer must contact Vicor to obtain a Return Material Authorization (RMA) number and shipping instructions. Products returned without prior authorization will be returned to the buyer. The buyer will pay all charges incurred in returning the product to the factory. Vicor will pay all reshipment charges if the product was defective within the terms of this warranty.

Information published by Vicor has been carefully checked and is believed to be accurate; however, no responsibility is assumed for inaccuracies. Vicor reserves the right to make changes to any products without further notice to improve reliability, function, or design. Vicor does not assume any liability arising out of the application or use of any product or circuit; neither does it convey any license under its patent rights nor the rights of others. Vicor general policy does not recommend the use of its components in life support applications wherein a failure or malfunction may directly threaten life or injury. Per Vicor Terms and Conditions of Sale, the user of Vicor components in life support applications assumes all risks of such use and indemnifies Vicor against all damages.

## **Vicor's comprehensive line of power solutions includes high density AC-DC and DC-DC modules and accessory components, fully configurable AC-DC and DC-DC power supplies, and complete custom power systems.**

Information furnished by Vicor is believed to be accurate and reliable. However, no responsibility is assumed by Vicor for its use. Vicor components are not designed to be used in applications, such as life support systems, wherein a failure or malfunction could result in injury or death. All sales are subject to Vicor's Terms and Conditions of Sale, which are available upon request.

**Specifications are subject to change without notice.**

## **Intellectual Property Notice**

Vicor and its subsidiaries own Intellectual Property (including issued U.S. and Foreign Patents and pending patent applications) relating to the products described in this data sheet. Interested parties should contact Vicor's Intellectual Property Department.

**Vicor Corporation**  
25 Frontage Road  
Andover, MA, USA 01810  
Tel: 800-735-6200  
Fax: 978-475-6715

### **email**

Customer Service: [custserv@vicorpower.com](mailto:custserv@vicorpower.com)  
Technical Support: [apps@vicorpower.com](mailto:apps@vicorpower.com)