



Data Sheet

MI-AIM

AC Input Front End Module

Features

- Inputs: 115 Vac 60/400 Hz
- Output power: 250 W
- MIL-STD-704A input transient protection
- MIL-STD-461D/E EMI compliant*
- MIL-STD-810, MIL-STD-202 environments
- Compatible with MI-x7x family modules
- Efficiency: 95%
- Operating temperature to 100 °C
- Size: 2.28" x 2.4" x 0.5" (57,9 x 61,0 x 12,7 mm)



Actual size:
2.28 x 2.4 x 0.5 in
57,9 x 61,0 x 12,7 mm

Product Highlights

The AC input module interfaces directly with AC mains to provide line rectification, EMI filtering, transient protection, and inrush limiting. These front-end modules accept 115 Vac and provide 250 W of output power for any of Vicor's MI-x7x family of standard and junior size modules.

The MI-AIM meets CE102 conducted emissions requirements of MIL-STD-461D/E* and the transient and spike requirements of MIL-STD-704A.

Fully encapsulated in Vicor's industry standard package, the MI-AIM meets MIL-STD-810 Environmental testing requirements for humidity, fungus, salt-fog, explosive atmosphere, acceleration, vibration and shock.

Packaging Options

Standard: Slotted baseplate

SlimMod: Flangeless baseplate, option suffix: - S
Example: MI - AIM - M1 - S

FinMod: Finned heat sink, option suffix:
- F1, - F2, -F3 or -F4

Examples:

- MI - AIM - M1 -F1, 0.25" fins, longitudinal
- MI - AIM - M1 -F2, 0.50" fins, longitudinal
- MI - AIM - M1 -F3, 0.25" fins, transverse
- MI - AIM - M1 -F4, 0.50" fins, transverse

Input Characteristics

Parameter	Min	Typ	Max	Unit	Notes
AC line input	85	115	140	Vac	
	47	60/400	440	Hz	Operates over entire range
Inrush current			40	A, peak	125 Vac
Conducted EMI*	CE102 per MIL-STD-461 D/E				100 – 125 Vac; 60 Hz
Input transient MIL-STD-704A/ MIL-HDBK-704-1-8	TABLE SAC109-II normal voltage transients				Performance Criteria: Nominal output voltage may deviate but self recovers
	TABLE SAC302-II abnormal voltage transients				Performance Criteria: Nominal output voltage may deviate but self recovers

*EMI performance is subject to a wide variety of external influences such as PCB construction, circuit layout etc. As such, external components in addition to those listed herein may be required in specific instances to gain full compliance to the standards specified.

Output Characteristics

Parameter	Min	Typ	Max	Unit	Notes
Output power		250		W	100 °C
Hold-up time	Application specific				A function of external capacitance and power
Efficiency		95%			115 Vac; 60/400 Hz

Model Selection Chart

Model Number	Compatible MI-Series	Converter	Operating Temp (°C)	Storage Temp (°C)
MI-AIM-M1	MI-27x/MI-J7x	M-grade	-55 to +85/+100	-65 to +100/+125
MI-AIM-I1	MI-27x/MI-J7x	I-grade	-40 to +85/+100	-55 to +100/+125

SPECIFICATIONS

(typical at $T_{BP} = 25\text{ }^{\circ}\text{C}$, nominal line and 75% load, unless otherwise specified)

■ SAFETY SPECIFICATIONS

Parameter	Min	Typ	Max	Unit	Notes
Dielectric withstand					
Input to output		None			Provided by DC-DC converter
Input/output to baseplate		1,500			V _{rms}

■ ENVIRONMENTAL – MIL-STD-810D

Parameter	Min	Typ	Max	Unit	Notes
Altitude - Method 500.2	70,000			feet	Procedure II
Humidity - Method 507.2	88/ 240			%/ hours	Procedure I, cycle 1
Acceleration - Method 513.3	9.0			g	Procedure II
Vibration - Method 514.3	20			g	Procedure I, category 6
Shock - Method 516.3	40			g	Procedure I

■ RELIABILITY – MIL-HDBK-217F (MI-AIM-M1)

Parameter	Min	Typ	Max	Unit	Notes
25 °C Ground Benign: G.B.		5,545		1,000 hrs	
50 °C Naval Sheltered: N.S.		998		1,000 hrs	
65 °C Airborne Inhabited Cargo: A.I.C.		782		1,000 hrs	

■ GENERAL SPECIFICATIONS

Parameter	Min	Typ	Max	Unit	Notes
Size		2.28 x 2.4 x 0.5 (57,9 x 61,0 x 12,7)		in (mm)	
Weight		3.0 (85)		Ounces (Grams)	

SPECIFICATIONS (cont.)

■ PRODUCT GRADE SPECIFICATIONS

Parameter	I-Grade	M-Grade
Storage temperature	-55 °C to +125 °C	-65 °C to +125 °C
Operating temperature (baseplate)	-40 °C to +100 °C	-55 °C to +100 °C
Power cycling burn-in	12 hours, 29 cycles	96 hours, 213 cycles
Temperature cycled with power off 17°C per minute rate of change	12 cycles -65 °C to +100 °C	12 cycles -65 °C to +100 °C
Test data supplied at these temperatures [a]	-40 °C, +80 °C	-55 °C, +80 °C
Warranty	2 years	2 years
Environmental compliance	MIL-STD-810	MIL-STD-810
Derating	NAVMAT P-4855-1A	NAVMAT P-4855-1A

[a] Test data available for review or download from vicorpower.com

■ ENVIRONMENTAL QUALIFICATIONS

Parameter	Qualification
Altitude	MIL-STD-810D, Method 500.2, Procedure III, explosive decompression (40 K ft.).
	MIL-STD-810D, Method 500.2, Procedure II, 40,000 ft., 1000 – 1500 ft./min. to 70,000 ft., unit functioning
Explosive Atmosphere	MIL-STD-810C, Method 511.1, Procedure I
Vibration	MIL-STD-810D, Method 514.3, Procedure I, category 6, helicopter, 20 g
	MIL-STD-810D, Method 514.3 random: 10 – 300 Hz @ 0.02 g ² /Hz, 2000 Hz @ 0.002 g ² /Hz, 3.9 total G rms 3 hrs/axis. Sine: 30 Hz @ 20 g, 60 Hz @ 10 g, 90 Hz @ 6.6 g, 120 Hz @ 5.0 g, 16.0 total G rms, 3 axes
	MIL-STD-810E, Method 514.4, Table 514.4-VII, ±6 db/octave, 7.7 G rms, 1hr/axis
Shock	MIL-STD-810D, Method 516.3, Procedure I, functional shock, 40 g
	MIL-STD-202F, Method 213B, 18 pulses, 60 g, 9 msec
	MIL-STD-202F, Method 213B, 75 g, 11 ms saw tooth shock
	MIL-STD-202F, Method 207A, 3 impacts / axis, 1, 3, 5 feet
Acceleration	MIL-STD-810D, Method 513.3, Procedure II Operational test, 9 g for 1 minute along 3 mutually perpendicular axes
Humidity	MIL-STD-810D, Method 507.2, Procedure I, cycle I, 240 hrs, 88% relative humidity
Solder Test	MIL-STD-202, Method 208, 8 hr. aging
Fungus	MIL-STD-810C, Method 508.1
Salt-Fog	MIL-STD-810C, Method 509.1

MECHANICAL DRAWINGS, CONNECTION DIAGRAM

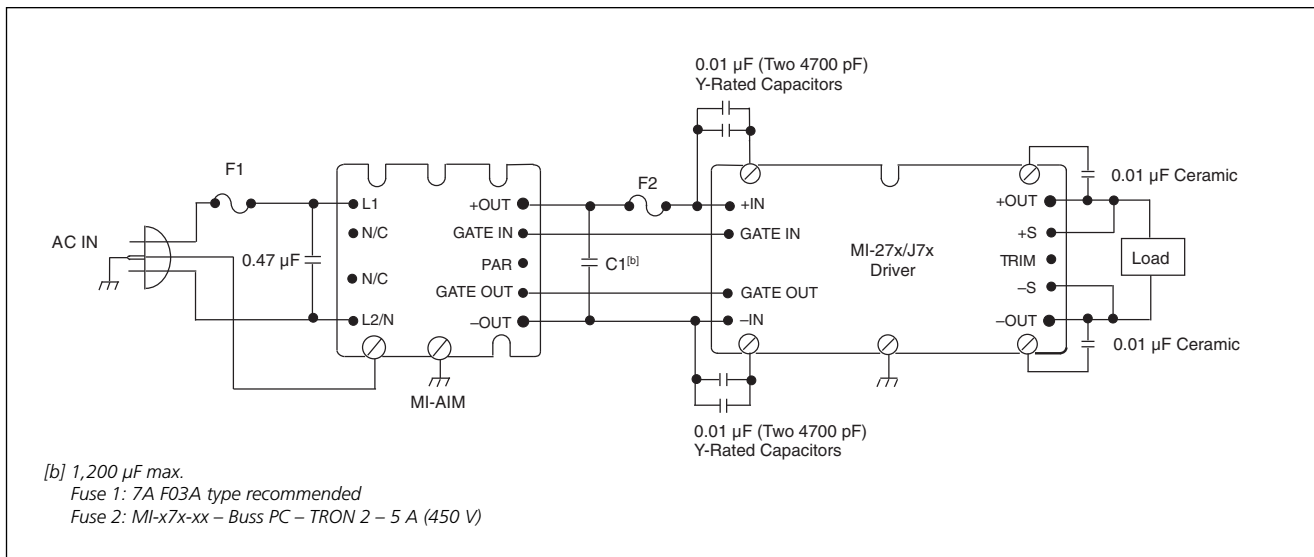

Figure 1 — MI-AIM Connection diagram, typical application

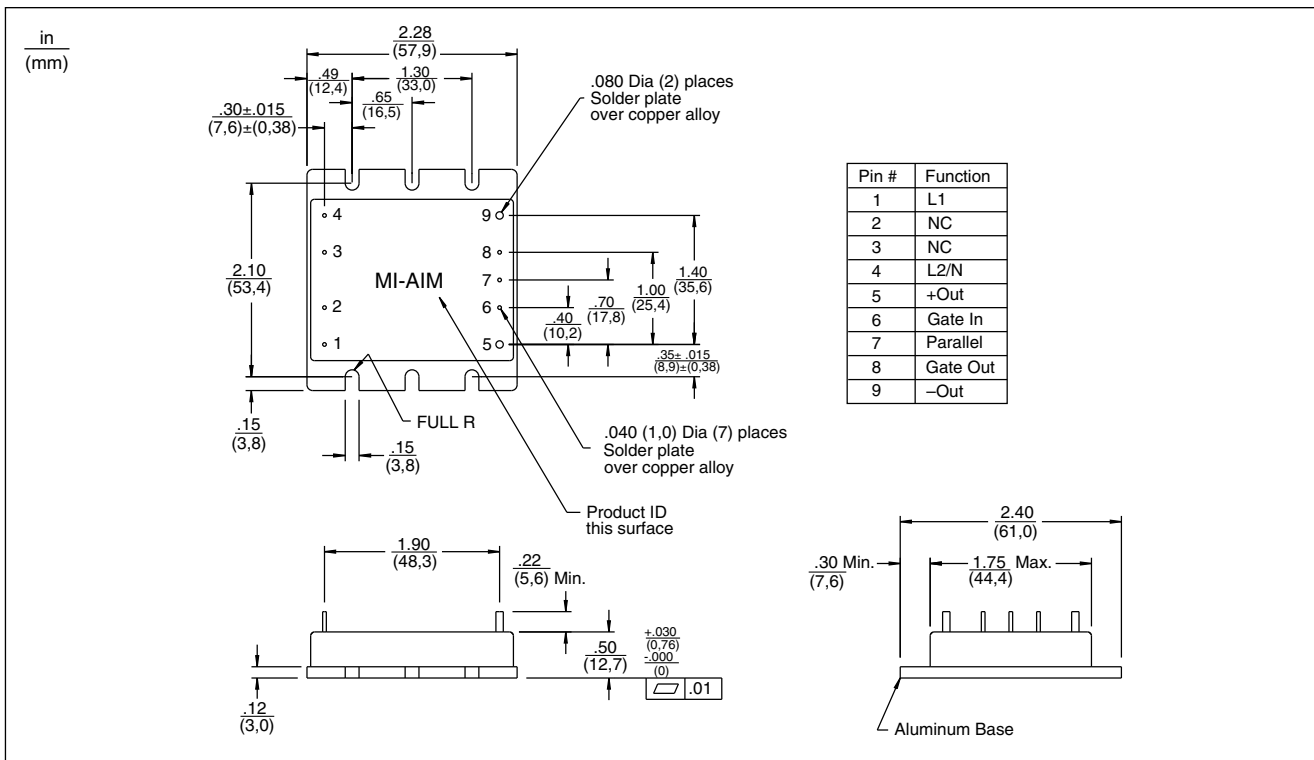

Figure 2 — Mechanical diagram

Note: For alternate packaging options refer to the mechanical drawing page at vicorpower.com

Warranty

Vicor products are guaranteed for two years from date of shipment against defects in material or workmanship when in normal use and service. This warranty does not extend to products subjected to misuse, accident, or improper application or maintenance. Vicor shall not be liable for collateral or consequential damage. This warranty is extended to the original purchaser only.

EXCEPT FOR THE FOREGOING EXPRESS WARRANTY, VICOR MAKES NO WARRANTY, EXPRESS OR IMPLIED, INCLUDING, BUT NOT LIMITED TO, THE WARRANTY OF MERCHANTABILITY OR FITNESS FOR A PARTICULAR PURPOSE.

Vicor will repair or replace defective products in accordance with its own best judgement. For service under this warranty, the buyer must contact Vicor to obtain a Return Material Authorization (RMA) number and shipping instructions. Products returned without prior authorization will be returned to the buyer. The buyer will pay all charges incurred in returning the product to the factory. Vicor will pay all reshipment charges if the product was defective within the terms of this warranty.

Information published by Vicor has been carefully checked and is believed to be accurate; however, no responsibility is assumed for inaccuracies. Vicor reserves the right to make changes to any products without further notice to improve reliability, function, or design. Vicor does not assume any liability arising out of the application or use of any product or circuit; neither does it convey any license under its patent rights nor the rights of others. Vicor general policy does not recommend the use of its components in life support applications wherein a failure or malfunction may directly threaten life or injury. Per Vicor Terms and Conditions of Sale, the user of Vicor components in life support applications assumes all risks of such use and indemnifies Vicor against all damages.

Vicor's comprehensive line of power solutions includes high density AC-DC and DC-DC modules and accessory components, fully configurable AC-DC and DC-DC power supplies, and complete custom power systems.

Information furnished by Vicor is believed to be accurate and reliable. However, no responsibility is assumed by Vicor for its use. Vicor components are not designed to be used in applications, such as life support systems, wherein a failure or malfunction could result in injury or death. All sales are subject to Vicor's Terms and Conditions of Sale, which are available upon request.

Specifications are subject to change without notice.

Intellectual Property Notice

Vicor and its subsidiaries own Intellectual Property (including issued U.S. and Foreign Patents and pending patent applications) relating to the products described in this data sheet. Interested parties should contact Vicor's Intellectual Property Department.

Vicor Corporation
25 Frontage Road
Andover, MA, USA 01810
Tel: 800-735-6200
Fax: 978-475-6715

email

Customer Service: custserv@vicorpower.com
Technical Support: apps@vicorpower.com