

POWER COMPONENTS SIMPLIFY 1 KW POWER DESIGN

By Jeff Ham
Sr. Application Engineer, Vicor



TPB 102

INTRODUCTION

Not long ago, designing a 1,000 W power supply for operation on worldwide AC lines was a task for the most experienced power design engineers. Besides dealing with the design of autoranging front-end rectification circuitry and isolated power conversion stages, the designer faced a myriad of other complex technical and design issues: inrush current limiting, sizing and selection of holdup capacitors, transient protection, thermal design, and worldwide safety agency and conducted noise requirements.

High-density power components simplify the design process. This issue of The Power Bench is presented in two parts. Part 1 outlines a step-by-step design example using off-the-shelf Vicor modular power components as the primary building blocks. Part 2 discusses some of the more important underlying issues in power supply design.

Design Element	Requirements
Input:	90-132/180-264 Vac Autoranging 47-63 Hz 5 mS Hold up Time <15 A Inrush @132 Vac Conducted EMI to EN55022 B Transient Withstand to IEC 61000-4-5, L3
Output:	48 Vdc Adjustable 1000 W@230 Vac Input Supply Efficiency 80% Minimum
Mechanical: Connectors	9.25" x 5.0" x 1.00" Excluding and Hold up Capacitors Weight: TBD Conduction Cooled
Storage Temperature:	-40°C to +105°C
Operating Temperature:	-20°C to +55°C
Notes:	1. Hold up capacitors to be remotely located from heat generating components for improved reliability. 2. Temperature is measured on mounting surface.

Table 1.

PART 1: STEP-BY-STEP DESIGN EXAMPLE

Step 1: Define Requirements: For this example, the design requirements are as specified in Table 1.

Step 2: Identify Components: A Vicor VI-ARMB-C22, which is capable of delivering 750 W@115 Vac and 1500 W@230 Vac, is used as the autoranging front-end. This micro-size module measures only 2.28" x 1.45" x 0.5" and includes inrush current limiting.

The output of an autoranging front-end typically ranges from 200 to 375 Vdc, so a nominal 300 V input DC-DC converter will suffice. Two Vicor 500 W, V300A48C500B modules — connected in parallel to achieve the required output power — are used in this example. At 4.6" x 2.2" x 0.5" each, the pair fit easily within the space allocated. See Figure 1.

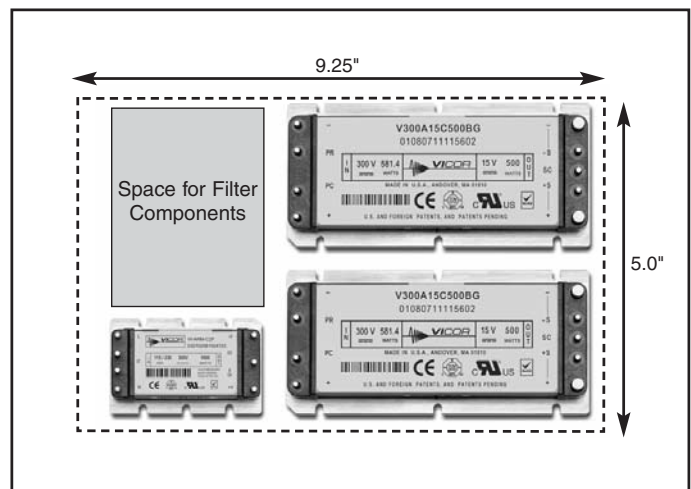

Figure 1. Two 300 V input DC-DC converter modules and an autoranging front end easily satisfy the electrical and space requirements.

Step 3: Develop Schematic: The EMI filter design and interconnect scheme shown in Figure 2 are taken from the Vicor Applications Manual. The filter provides the EMI attenuation needed to meet EN55022 B.

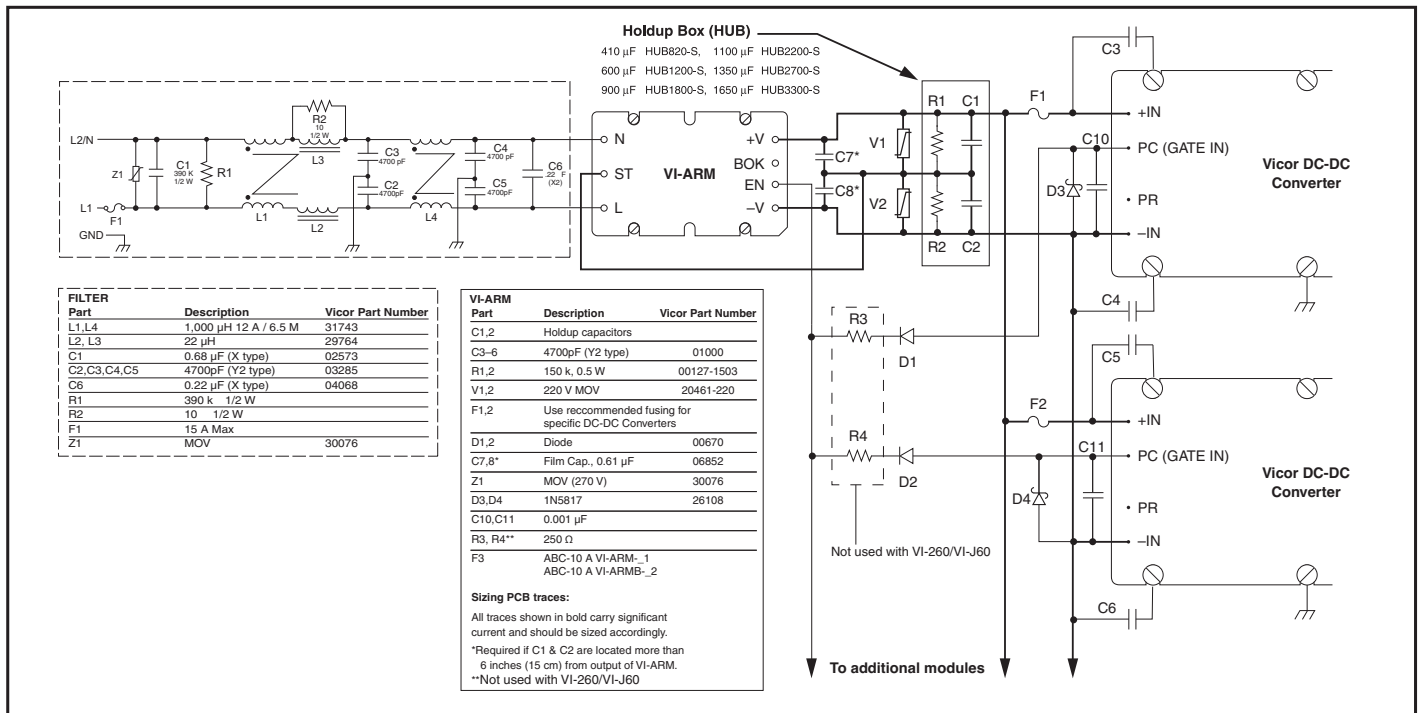

Figure 2. Interconnects for a 1 kW power supply utilizing component power modules.

Step 4: Check Thermals: By requirement, this is a conduction-cooled application, so the parameter of interest is the maximum allowable thermal impedance between the baseplate and the environment. For this we use the worst-case numbers available. The converters and the VI-ARM have a worst-case efficiency of 89% and 94% respectively, so the combined worst-case efficiency is 83.66%. To determine the maximum thermal impedance, the thermal calculator (Figure 3) provided on the Vicor website¹ or the equations in the expanded discussion below can be used. The resultant maximum tolerable thermal impedance is 0.23°C/W. For conservative design, 75% of the calculated thermal impedance gives a design goal thermal impedance of 0.17°C/W.

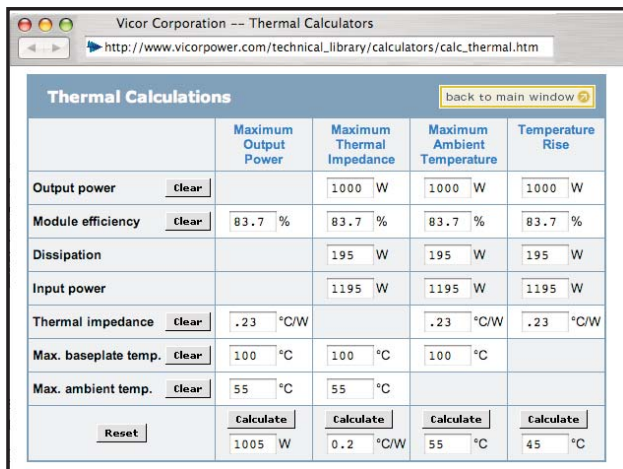

Figure 3. Online Thermal Calculator

Step 5: Size the Hold up Capacitors: The curves shown in Figure 4 taken from the Vicor Applications Manual indicate that for a 5 ms hold up time the minimum needed capacitance is 1300- μ F. A higher value (e.g., 1800- μ F) would provide hold up margin and reduce the ripple voltage at the converter input from ~20-Vp-p to ~15-Vp-p.

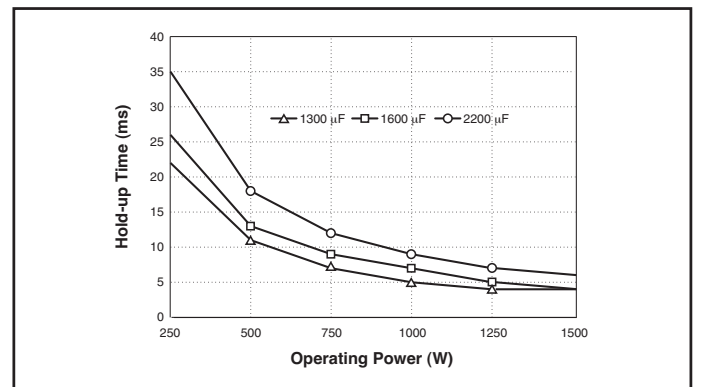

Figure 4. Hold up Time vs. Operating Power and Capacitance.

PART TWO: TYPICAL POWER SUPPLY DESIGN CONSIDERATIONS

AC-DC Rectification: A fuse, full-wave bridge rectifier, and hold up capacitors are typically the minimum components needed for AC voltage rectification to provide a DC level suitable for use with commercially available DC-DC converters (Figure 5).

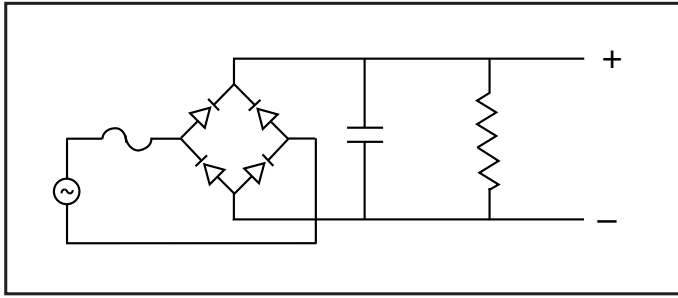

Figure 5. Basic bridge rectifier circuit

For most applications this level of simplicity is not sufficient to meet regulatory agency requirements for EMI and transients. In addition to these requirements, the wide range in DC voltage developed by this approach makes designing a DC-DC converter difficult. If, for example, an OEM wants to sell their product domestically and overseas, the range of DC would result in a low at 85 Vac of 120 Vdc to a high at 264 Vac of 373 Vdc. To achieve a high power output over this greater than 3:1 input range, and build in margin to accommodate the ripple present on the input, places high demands on the switching components used within the DC-DC converter.

To ease the demands on the DC-DC converter a voltage doubling circuit is typically used (Figure 6). This circuit requires that a connection, called a strap, be made for operation at the intended source voltage. This circuit yields DC levels in the range of 240 Vdc to 370 Vdc, which is considerably narrower than straight rectification provides. Circuits which automatically sense the applied AC voltage and either double or remain in the bridge mode are called autoranging front-ends. This voltage doubling scheme does have a drawback. Consider the manually strapped circuit: if the doubling circuit is engaged and the unit plugged into a 230 Vac source the resultant DC voltage would be in excess of 650 V! Autoranging circuits are less prone to this; nevertheless, line transients can cause the same effect. Clearly, protective devices must be used to prevent the converters from seeing abnormal voltages.

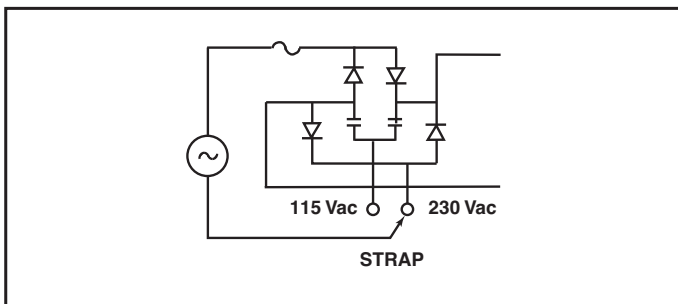

Figure 6. Basic voltage doubling circuit

Input Protection: Protection of the DC-DC converters from excessive input voltage as well as fast voltage rise times (dv/dt) is necessary, but the sources of these conditions and the means to quell them may not be obvious.

As mentioned previously, autoranging front-ends employ voltage doubling when connected to a nominal 115 Vac line. A line transient or surge of sufficient amplitude and duration impressed upon the input voltage could cause the doubler circuit to be "fooled". The event could be caused by misapplication of the input voltage during equipment testing or loading changes as equipment is cycled on and off. The latter is of particular concern in generator applications. Environmental causes such as lightning or blown fuses cause large transient voltages to appear on the line.

Surges are relatively slow increases in voltage. They can be handled by devices which suppress the incoming surge. These may be active or passive depending upon the expected severity of the surge; they effectively clamp the voltage at a predetermined level.

Transients, in contrast to surges, are typically high amplitude, fast rise time, short duration events. A Zener diode (Transorb™ or the like) will suppress transients of under 100 μ s, act as a voltage clipper for DC input transients, and also provide reverse input polarity protection. The device should be chosen above the high line voltage limits so as to not conduct during normal operation. Depending upon the severity of the events expected, it may be necessary to incorporate an LC filter. This filter will integrate the transient energy while the Zener clips the voltage. Metal Oxide Varistors (MOVs) are frequently employed across the line and neutral inputs as inexpensive insurance against transients.

Gas discharge tubes are used as a fail safe against input overvoltage in many instances. These devices have the advantage of being able to handle large amounts of energy such as typically found stored in the hold up capacitors of an AC front-end.

Filtering: Most DC-DC converters today utilize high frequency switching topologies to achieve voltage regulation at their output. All switching converters produce noise. One should not focus on the frequency at which the converter is operating, but rather on the spectrum of noise energy it produces. By their nature, some topologies perform better than others. The two predominant topologies are Pulse Width Modulated (PWM) and Quasi-resonant Zero-Current-Switching (ZCS) converters. Typically, the latter method produces less noise due to the smoother, sinusoidal current wave form inherent in the design. This is important because agency standards dictate the amount of noise allowed back on

the AC line from a power supply. If the power supply produces less noise to begin with, it will be easier to meet the requirements.

For example, the European Community requires compliance to EN55022, which focuses on the noise generated by power supplies in the frequency spectrum from 150 kHz to 30 MHz. Within this range there are limits, depending upon the class of product, of how much noise is allowed at different frequencies. If the power supply does not meet these limits alone, a filter designed to provide additional attenuation at the frequencies of interest must be constructed. In general, more attenuation requires components of higher number or size. These standards also relate to the type of noise generated (e.g., input conducted common mode). Both EMI suppression as well as input transient and surge protection are required to meet today's standards.

The EMI filter schematic shown in front of the VI-ARM (in Figure 2) is an example of what is typically required to meet the requirements of EN55022 level B. This type of filter can usually be found as a single package from a variety of vendors.

Thermal and Mechanical Issues: Energy conversion is never 100% efficient. During the conversion process in a DC-DC converter, some energy is lost in the form of heat. Dealing with the heat generated by the conversion process should not be underestimated.

All power product manufacturers specify the maximum temperature at which their products can operate. Product reliability and operating life are inversely proportional to operating temperature. Assuring a robust design requires making certain that the limit is not exceeded under all operating conditions, and that sufficient margin is built into the design. This requires careful analysis, understanding of the application, and verification through experimentation that the chosen thermal management approach can deal effectively with the environmental demands.

The first step in this process is determining the worst-case power dissipation the system is likely to develop. One cannot assume that the published efficiency specification applies at all line, load, and temperature conditions; therefore, the manufacturer should be asked to provide a plot of the efficiency as a function of these parameters. Figure 7 shows such a plot for a Vicor DC-DC converter Model V300A48C500BL, a 300 Vdc nominal input, 48 Vdc output 500 W device (used as part of the design example in Part 1).

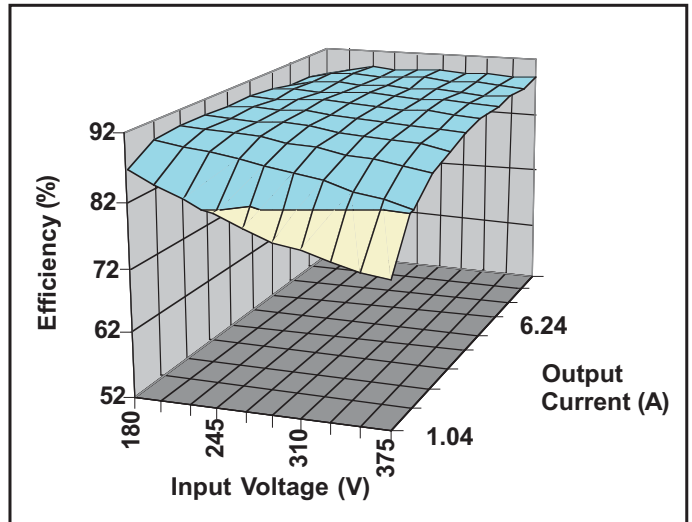

Figure 7. Efficiency vs. input voltage and output current

The efficiency plot shown in Figure 7 remains very flat over most of the operating range. The expected worst case efficiency, however, should be used in your calculation. This point typically happens at the full load rating of the converter, but most designs do not operate at the full load rating of the device. That is why it is important to look at the full efficiency curve.

From the curve, the efficiency at nominal line is 89% ($\eta = 0.89$) for the bulk of the output range. If we were operating this converter at full load ($P_o = 500$ W) the power dissipated (P_d) as heat is:

$$P_d \equiv \frac{P_o}{\eta} - P_o \quad (1)$$

which yields $P_d = 61.8$ W.

For this product, the maximum operating temperature as measured on its baseplate is 100°C (T_b). Manufacturers publish thermal impedance (θ) values expressed in °C/W. The thermal impedance value for this converter in free air is given as 4.9°C/W.

Therefore, the temperature rise over ambient is simply:

$$T_r \equiv P_d * \theta \quad (2)$$

which for this example is 302.8°C.

Because the maximum baseplate temperature was specified as 100°C by the manufacturer of the converter, there appears to be a problem. What is needed is a heat sink or other means of cooling the baseplate if we expect to get full power from the module.

In order to do this we need to determine what thermal impedance is required to keep the baseplate temperature within specification by finding the allowable temperature rise. In our example, the maximum ambient temperature to which the module will be exposed is 55°C. The allowable temperature rise is the difference between the maximum baseplate temperature and the maximum expected ambient temperature. In this case it would be 100°C - 55°C = 45°C.

The thermal impedance needed is the allowable temperature rise divided by the maximum power dissipated, Pd (Equation 3), which is 0.73°C/W. This is the maximum thermal impedance that can be tolerated, and will result in the module operating at its maximum rated temperature when delivering full load at the maximum ambient temperature.

$$\theta_{max} \equiv \frac{T_r \text{ allowed}}{P_d} \quad (3)$$

As stated earlier, for robustness and longevity the cooler the device operates the better. A derating factor of .75 should be applied to the maximum thermal impedance needed wherever possible.

Applying the derating factor results in a more desirable θ of 0.547°C/W. This low impedance can be achieved by employing natural convection cooling (the transfer of heat energy to a fluid, primarily air), forced convection cooling (the same, but using moving fluid), or conduction cooling (transfer of heat through a solid medium).

When convection cooling to air is employed it is best realized by adding surface area, either in the form of a heat sink or mounting the module to a panel. Many manufacturers offer heat sinks as an integral part of their product. Depending upon the application, forced air may be necessary to keep the device within its limits. Some also provide heat sinks as an accessory product. A number of heat sink manufacturers will design a solution based upon the information the power designer provides.

When conduction cooling is used, the thermal energy ultimately ends up being dissipated through convection. Consider the following thermal circuit: within a module the heat generated by the switching elements is conducted to the product baseplate. It then conducts through a thermal interface material to a metallic panel within a rack. The panel then dissipates the heat energy into the air via convection. A power supply mounted within a sealed NEMA enclosure is an ideal application for conduction cooling wherein the heat generated is transferred to the box itself and then to the surrounding air. When conduction cooling is employed, it is the responsibility of the user to ensure that the product

remains within its limits. The surface to which the product is mounted may not dissipate the heat efficiently. A series of tradeoffs will be needed to successfully implement the thermal management scheme. Some of the variables will be the physical space available, air flow if available, and orientation of the product within the system.

A conservative design philosophy is recommended. Verification of the thermal management system by direct measurement is encouraged. Obstructions, eddies, and installation errors can all serve to hinder airflow resulting in a significant loss of cooling capacity of an otherwise acceptable "paper" design.

THERMAL EXAMPLES:

EXAMPLE 1: Find the maximum ambient temperature at which a module can deliver full power of 400 W given the following information:

$$\eta = 86\% (0.86)$$

$$\theta_{max} = 0.77^\circ\text{C/W}$$

$$T_b = 100^\circ\text{C}$$

SOLUTION: Rearrange Equations 3 and 1:

$$T_{\text{ambient max}} = T_b - [\theta_{max}(P_d)]$$

$$T_{\text{ambient max}} = 49.86^\circ\text{C}$$

EXAMPLE 2: Determine the maximum tolerable thermal impedance from the module baseplate to air for a system delivering 300 W to a load given the following:

$$T_{\text{ambient maximum}} = 60^\circ\text{C}$$

$$\eta = 91\% (0.91)$$

$$T_b = 100^\circ\text{C}$$

SOLUTION: Determine the power dissipated (Pd) from Equation 1:

$$P_d = 29.67 \text{ W}$$

Calculate the maximum allowable temperature rise from Equation 3:

$$T_r \text{ allowable} = T_b - T_{\text{ambient maximum}}$$

$$T_r \text{ allowable} = 40^\circ\text{C}$$

Calculate the maximum thermal impedance:

$$\theta_{max} = T_r \text{ allowable} / P_d$$

$$\theta_{max} = 1.35^\circ\text{C/W}$$

Sizing the Hold up Capacitors: Hold up capacitors are bulk energy storage units which provide the energy to sustain power to the DC-DC converters during the “valley” of the rectified AC waveform. In addition, the amount of capacitance determines how long the power supply remains operational after loss of AC input, as well as the amount of ripple on the converters. These concepts are best understood by looking at Figure 8.

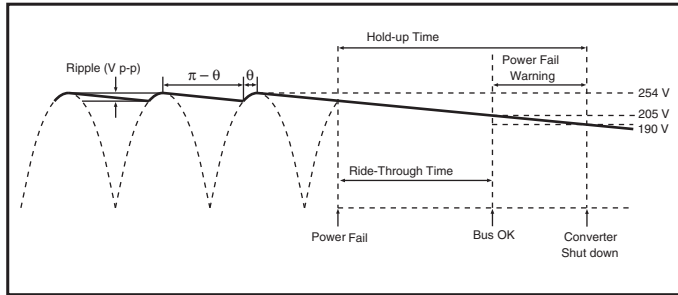

Figure 8. Hold up time / ride-through time

Hold up capacitor values depend on the required output bus voltage ripple, power fail hold up time, and ride-through time. Many applications require the power supply to maintain output regulation during a momentary power failure of specified duration, i.e., the converters must hold up or ride-through such an event while maintaining the output voltage. Similarly, many of these same systems require notification of an impending power failure in order to allow time to perform an orderly shut down.

The energy stored on a capacitor which has been charged to voltage V is:

$$\mathcal{E} = 1/2(CV^2) \quad (4)$$

where \mathcal{E} is the stored energy, C is capacitance, and V is the voltage across the capacitor.

Energy is given up by the capacitors as they are discharged by the converters. The energy expended (the power-time product) is:

$$\mathcal{E} = P\Delta t = C(V_1^2 - V_2^2) / 2 \quad (5)$$

where P is operating power, Δt is the discharge interval, V_1 is the capacitor voltage at the beginning of Δt , and V_2 equals capacitor voltage at the end of Δt .

Rearranging Equation 5 to solve for the required capacitance:

$$C = 2P\Delta t / (V_1^2 - V_2^2) \quad (6)$$

The hold up time (Δt) is defined as the interval between power fail warning (BOK) and converter shut down (EN) as illustrated in Figure 8. The Bus-OK and Enable thresholds are 205 V and 185 V, respectively for the chosen modules. A simplified relationship between hold up time, operating power, and bus capacitance is obtained by inserting these constants:

$$C = 2P\Delta t / (205^2 - 185^2)$$

$$C = 2P\Delta t / (7,800)$$

It should be noted that the series combination C1, C2 (Figure 2) requires each capacitor to be twice the calculated value, but the required voltage rating is reduced to 200 V.

Allowable ripple voltage on the bus (or ripple current in the capacitors) may define the capacitance requirement. Consideration should be given to converter ripple rejection and resulting output ripple voltage. The ripple rejection (R) of many Vicor converters is specified as a function of the input / output voltage ratio:

$$R = 30 + 20\log(V_{IN} / V_{OUT}) \quad (7)$$

For example, a converter whose output is 48 V and nominal input is 300 V will provide about 46 dB ripple rejection, i.e., 10 V p-p of input ripple will produce 20m V p-p of output ripple. (See Figure 9.) Equation 6 is again used to determine the required capacitance. In this case, V_1 and V_2 are the instantaneous values of bus voltage at the peaks and valleys (Figure 8) of the ripple, respectively. The capacitors must hold up the bus voltage for the time interval (Δt) between peaks of the rectified line as given by:

$$\Delta t = (\pi - \theta) / 2\pi f \quad (8)$$

where f is the line frequency and θ is the rectifier conduction angle.

The approximate conduction angle is given by:

$$\theta = \text{Cos}^{-1}V_2 / V_1 \quad (9)$$

Another consideration in hold up capacitor selection is their ripple current rating. The capacitors' rating must be higher than the maximum operating ripple current. The approximate operating ripple current (rms) is given by:

$$I_{RMS} = 2P / V_{ac} \quad (10)$$

where P is the operating power level and V_{ac} is the operating line voltage.

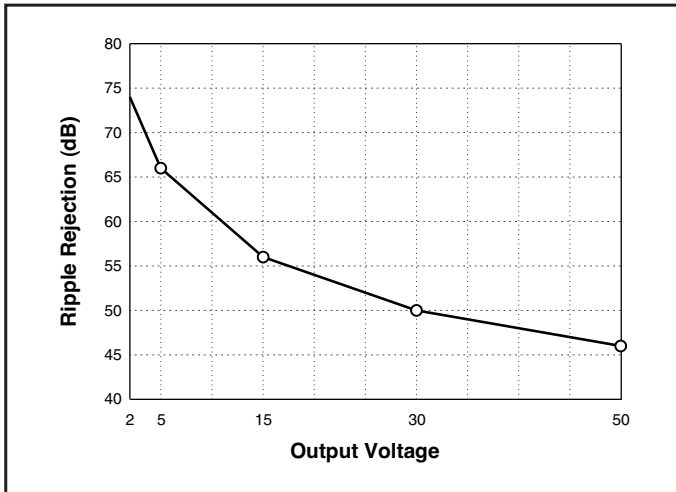

Figure 9. Converter ripple rejection vs. output voltage

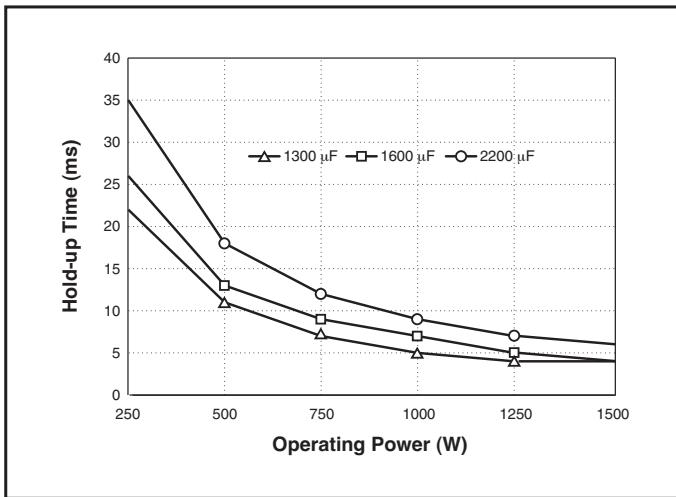

Figure 10. Hold up time vs. operating power and total bus capacitance, series combination of C1, C2

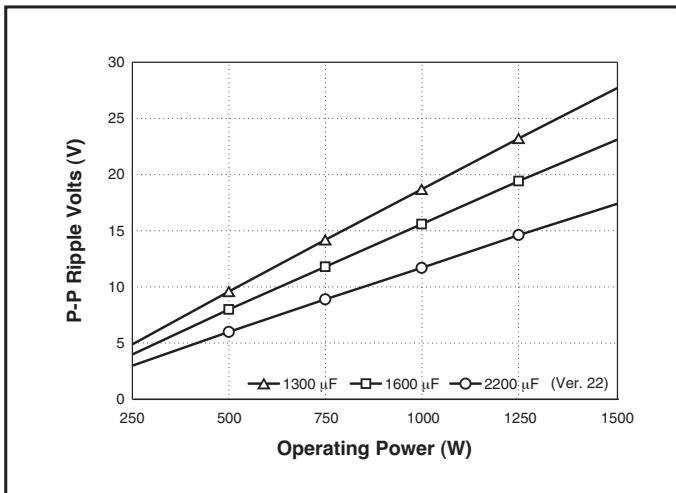

Figure 11. Ripple voltage vs. operating power and bus capacitance, series combination of C1, C2

Calculated values of bus capacitance for various hold up time, ride-through time, and ripple voltage requirements are given as a function of operating power level in Figures 10 and 11, respectively.

From the curves shown in Figure 10, the minimum desired total hold up capacitance is 1300 μF. For extra hold up a 1800 μF value can be used. This would also serve to reduce the ripple voltage at the converter input from ~20 Vp-p to ~15 Vp-p.

CONCLUSION

Design of 1,000 W power supply with the need for AC-DC rectification and DC-DC conversion impose a number of considerations. They include the desirability of autoranging to accommodate a wide range of input source voltages (to meet both domestic and international applications), protection from transients, and meeting agency requirements for noise. Additional design considerations, such as efficiency, thermal management, inrush current, and hold up time also need to be addressed.

The design example of Part 1 demonstrates that a high-power, high-efficiency power supply is readily achieved with a minimum of design effort by using off-the-shelf modular components. The field-proven modular power components offer high power density, efficiency, and overall performance, and are agency approved to worldwide standards.

In contrast, Part 2 shows that, in fact, the design of 1,000 W power supply requires a detailed understanding of a number of significant issues and a substantial level of design expertise. These underlying issues have already been addressed and, for the most part, incorporated into the design of modular power components and accessories.

For more information or to discuss your specific application requirements, please contact Vicor Applications Engineering at 1-800-927-9474.

¹ Calculators for thermal impedance as well as use of thermal equations in typical examples are available on the Vicor website (vicorpower.com).