

Material Composition Survey and Response Manual

December 15, 2006 Third Edition

(Data Format Ver. 3.21 compliant)

Japan Green Procurement Survey Standardization Initiative



Revision History:

January 6, 2006: First Edition – Newly created upon the introduction of the JIG

May 26, 2006: Second Edition

Revised content:

- (1) Exhibit 2: Five items added to intended use classification (Pb-R-10, 11, 12, 13, 14).
- (2) Exhibit 6: In accordance with the revisions to Exhibit 2, the data format has been updated to Ver. 3.10.

December 15, 2006: Third Edition

Revised content:

- (1) Indication of required data entry fields
- (2) Exhibit 2: Ten items added to intended use classification (Cd-R-3, Cr-R-2, Pb-R-15-22).
- (3) Exhibit 6: In accordance with the revisions to Exhibit 2 and change of the limitation in the number of text entry, the data format has been updated to Ver. 3.21.

Table of Contents

Introduction.....	P.3
1. Purpose.....	P.3
2. Scope of Application.....	P.4
3. Definition of Terms.....	P.4
4. Response Format.....	P.5
5. Survey Items.....	P.5
6. Response Methods and Survey Response Format (Data Format).....	P.11
7. Formats for Handwritten Response.....	P.11
8. Operation Flow.....	P.11
9. Supplementary.....	P.12
10. Attachments	
Annex A. Survey Substance List (Level A JIG 101).....	P.12
Annex B. Survey Substance List (Level B JIG 101).....	P.12
Exhibit 1. Flow Chart for Content Flag by Threshold Level.....	P.13
Exhibit 2. Intended Use Classification List (Level A: Four Heavy Metals).....	P.14
Exhibit 3. Intended Use Classification List (Level A: Others & Level B).....	P.15
Exhibit 4. Examples of Application Areas.....	P.16
Exhibit 5. JIG Detailed Chemical Lists (with Metal Conversion Factor).....	P.19
Exhibit 6. Survey Response Format (Data Format).....	P.28
Exhibit 7. Format 1 (Standard Type) for Handwritten Response.....	P.30
Exhibit 8. Format 2 (Detailed Type) for Handwritten Response.....	P.32

Introduction

Since its establishment in January 2001, the Japan Green Procurement Survey Standardization Initiative (hereinafter abbreviated as “JGPSSI”) has conducted investigations in order to create a reliable, efficient survey system by standardizing the survey regarding the material composition of electrical and electronic equipment. In July 2003 the JGPSSI issued the survey guidelines that define the list of substances covered by the standardized survey and the survey response format in an effort to promote green procurement survey standardization.

On the other hand, with a view to establish global standards, the JGPSSI has tirelessly worked in partnership with the Electronic Industries Alliance (EIA) and the European Information and Communications Technology Industry Association (EICTA) to develop standardized guidelines. As a result, the Joint Industry Guide (JIG) was successfully issued in May 2005. The official English name of these guidelines is the “Joint Industry Guide (JIG) for Material Composition Declaration for Electronic Products.”

The objective of the JIG is to define chemical substances in products for material composition declaration and declaration standards. This serves as a useful tool for both suppliers and customers as it facilitates a consistent and efficient survey process between the two parties.

The JGPSSI has adopted the JIG as its guidelines and proposes the survey and response format in accordance with the JIG.

1. Purpose

This survey and response manual defines the essence of the survey of material composition and its response methods based on the JIG survey and response format.

The survey is designed for a requester to receive a response from the primary suppliers. As shown in the figure below, it is on the premise that each requester conducts a similar survey by going back along the supply chain and that the information on material composition of products is accurately communicated from upstream suppliers (material manufacturers) to the downstream supplier (set manufacturers).

For the principles of survey and response, see “Guidelines for the Management of Chemical Substances in Products” issued by the JGPSSI.

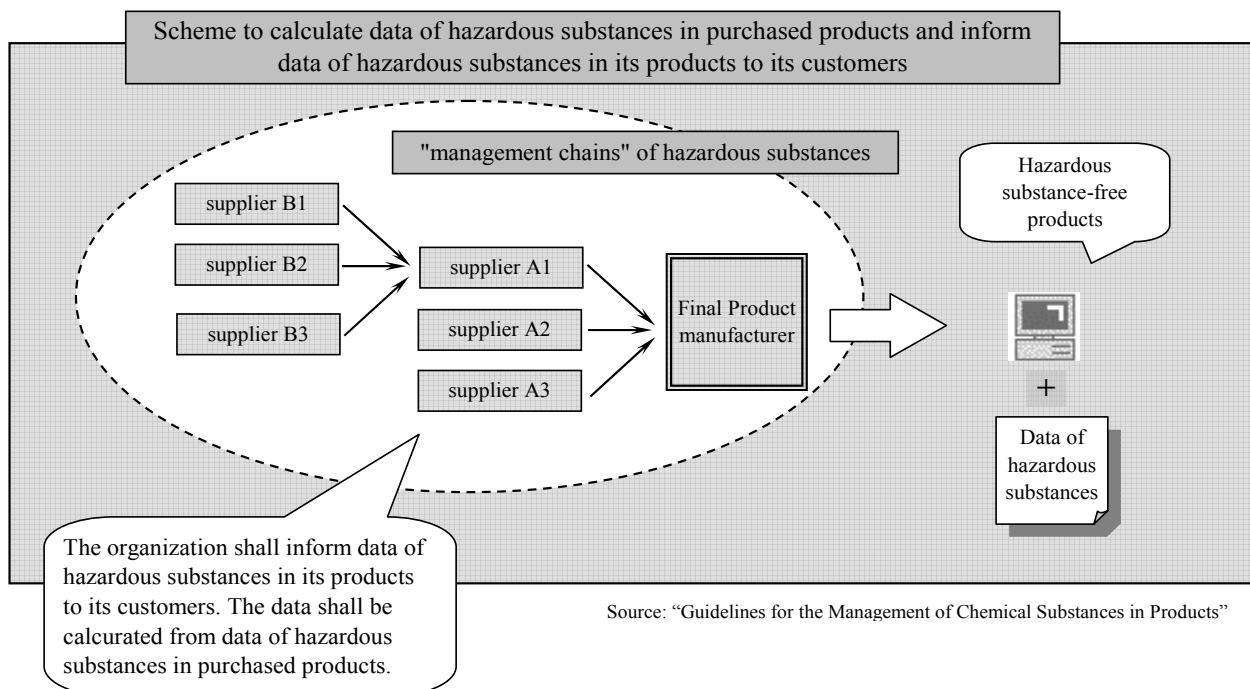

For the principles of survey and response, see “Guidelines for the Management of Chemical Substances in Products” issued by the JGPSSI.

This survey is intended for companies to manage material composition of products and does not serve the following purposes:

- (1) Proof of non-inclusion of certain chemical substances, assurance for compliance with applicable laws and regulations, and analysis requirements for assurance.
- (2) Interpretation of laws and regulations.
- (3) Provision of information to end-users upon making purchase decisions, etc.

2. Scope of Application

The survey established based on this manual is conducted on products, subparts and materials that consist of electrical and electronic equipment (including accessories). This does not apply to the following materials:

- (1) Packing materials used by a respondent to transport and store the product sold to the requester.
- (2) Indirect components and sub-materials used in the manufacturing process that do not comprise products/subparts.

3. Definition of Terms

- (1) Product
The item that the respondent is supplying (e.g. assembly, subassembly, component, raw material). A product may include product families if the products within those families perform the same function and have consistent material declarations.
- (2) Subpart
A sub-unit of product.
- (3) Material/Substance category
A generic term for surveyed chemical substances and their compounds. See Annex A (Level A) and Annex B (Level B).
- (4) Intentionally added
The state in which chemical substances are added in order to add a certain function to the product or subpart.
- (5) Threshold level
Concentration level which defines the limit above which the presence of a substance or material in a product or subpart must be declared based on the requirements of this guide.
A threshold level consists of two indicators: either “intentionally added” or numerical value (xxx ppm).
- (6) Impurity
Substance contained in a natural material that cannot be completely removed using industrial technology during the industrial refining process or a substance produced during a synthetic reaction process that cannot be completely removed using industrial technology. If a substance is used for the purpose of changing material properties, it should be indicated as “intentionally added.”
- (7) Recycled materials
Although there is no absolute definition of “recycling,” it is generally used to mean the “reuse or recycling of natural resources and waste” and “recycled materials” refer to materials that are to be reused or recycled.
Recycled materials are classified into “closed recycled materials” whose identity and chemical substances and other materials intentionally added to them are known and “open recycled materials” obtained from the market whose identity and inclusion of chemical substances are unknown.
- (8) Material contamination
A substance mixed in the material during the manufacturing process. Although contamination at less than the threshold level is tolerated, it is desirable to reduce it.
- (9) Application area
An area among the constituent components of subparts that contains surveyed chemical substances.
- (10) Purpose of use/intended use
Performance and functions intended to be enhanced by adding chemical substances to a product or subpart.

4. Response Format

There are two types of response formats depending on the response method: Format 1(Standard Type) and Format 2 (Detailed Type).

Format 1 (Standard Type) can be used for surveying materials, subparts, units, and products. The amount of surveyed chemical substances in products should be reported as total content.

* The JGPSSI recommends Format 1 (Standard Type).

Format 2 (Detailed Type) is designed for a survey targeted at materials and subparts. The amount of surveyed chemical substances in products should be reported for each application area they are contained. (Application area could be added up to 50 lines per part. If additional lines exceed 50, then use Format 1 (Standard Type)).

5. Survey Items

Items marked with * are those which are listed in the data field of JIG Annex C.

(1) Requester information

Respondents should not enter or make any changes to these items.

1) Reference number

Used by a requester to manage a survey by survey file, and is entered by the requester.

2) Requester's date of data entry

Enter the date of survey request by the requester.

3) Company name

Information on the requester.

4) DUNS number

Information on the requester.

(Note) DUNS number is a nine-digit company identification code issued by D&B.

5) Division name

Information on the requester.

6) Contact name

Information on the requester.

7) Telephone number (contact information)

Information on the requester.

8) Fax number

Information on the requester.

9) E-mail address

Information on the requester.

10) Requester's management items 1-3

Additional information on requester should be entered here. These items are used based on the requester's settings. Do not use these items for any other purposes. (Ex: section code, factory code)

(2) Respondent information

1) Respondent's date of data entry*

Enter the date of response. This field is required.

2) Company name*

Enter respondent's company name. This field is required.

If the respondent is a trading company, enter the information as a trading company instead of a manufacturer.

- 3) DUNS number: DUNS*
Leave it blank if it is unknown.
- 4) Address*
Input the respondent's address.
- 5) Division name
Enter respondent's division name.
- 6) Contact name*
Enter the name of the person in charge of reporting the survey data. This field is required.
Follow the requester's instructions if any.
- 7) Telephone number This field is required.
Enter the telephone number of the person indicated in item 6) or the person in charge of inquiries regarding the survey data. Follow requester's instructions if any.
- 8) Fax number
Enter the fax number of the person indicated in item 6) or the person in charge of inquiries regarding the survey data. Follow requester's instructions if any.
- 9) E-mail address*
Enter the e-mail address of the person indicated in item 6) or the person in charge of inquiries regarding the survey data. Follow requester's instructions if any.
- 10) Requester's management items 4-6
These items are set and used by the requester to manage the information on the respondent. Do not use these items for any other purposes. (Ex: supplier's name, supplier's code)
- 11) Additional information regarding survey response*
This includes overall comments on survey responses (and is entered by the respondent).

(3) Product/subpart/material information

- 1) Product/subpart number of requester* This field is required (only when there is no data in 3) Material identification information below).
The product/subpart management number used by the requester. In principle, it is entered by the requester.
- 2) Product/subpart/material name of requester
The product/subpart/material name the requester uses for the surveyed items. In principle, it is entered by the requester.
- 3) Material identification information
This item is used for materials to be surveyed by the requester when the product/subpart number listed in the above item 1) is not available. It is used when the requester provides the information for identifying materials to be surveyed by respondents. Based on this information, respondents can identify materials to be surveyed. In principle, it is entered by the requester.
 - 3)-1 Material grade number
The grade number identifying materials should be entered here. It is mainly used for resins and related materials.
 - 3)-2 Metal/JIS symbols
Metal symbols identifying metals or metal symbols specified by JIS should be entered here. These symbols are used primarily for metal materials.
 - 3)-3 Coloring number
The coloring number identifies the color of a material. This number is equivalent to a number managed by the material manufacturer or the colorant company. It is used primarily for resins and related materials.

- 3)-4 Thickness (mm)
This information identifies the thickness of a material. The unit is measured in mm. It is mainly used for flat materials (e.g. metal steel plates, sheet materials).
- 3)-5 Color
This is used when the coloring number in the above item 3)-3 is not available and the information on material color can be identified by letters.
- 3)-6 Diameter (mm)
This information identifies the diameter of a material. The unit is measured in mm. It is primarily used for cylindrical materials.
- 4) Requester's items 1-3
In principle, these items are entered by the requester to identify and manage the surveyed items.
(Note) This is the data field used for data management. Do not use it for individual survey.
Respondents should not enter these items.
- 5) Manufacturer name
Enter the manufacturer's name of the surveyed items. This field is required.
- 6) Respondent's product/subpart/material number* This field is required.
This number identifies respondent's product/subpart/material. In principle, it is entered by the respondent.
- 7) Respondent's product/subpart/material name*
A product provided or to be provided by the respondent. In principle, it is entered by the respondent.
- 8) Respondent's items 1-3
Respondent's items 1-3 are used by the respondent (respondent's memo).
- 9) Data version
Enter the management number that identifies the version of the survey response data used by the respondent. Keep it blank if it is not applicable.
- 10) Revision date
Enter the date when you finalize the responded data or the data of the relevant version.
- 11) Survey unit This field is required.
Choose the unit of the surveyed item when reporting its content. If the survey unit is set by the requester, please follow the requester's instructions.
e.g.) In the case of a subpart, "quantity" is used in principle. For raw materials, choose the most appropriate unit from "kg," "cm2," "m2," "m3," "m," "liter," or "g."
- 12) Survey unit mass (g/survey unit)* This field is required.
Enter the total mass per surveyed unit chosen in item 11).
e.g.) If the survey unit is "quantity" → Mass per surveyed item
If the survey unit is "kg" → Mass per 1kg of surveyed item = 1000g
- 13) Overall content flag This field is required.
Input Y when one or more content flag out of 24 substance categories is Y. Input N when all of content flags are N.

(4) Material/substance information

(Note): Please note that Format 1 (Standard Type) and Format 2 (Detailed Type) share some items that can be answered in the same way and others that should be answered in different ways.
Although breakdown substances are not meant to be surveyed, check whether the substance group to be surveyed is contained using the JIG Detailed Chemical List (Exhibit 4).

Items marked with* in the material/substance information are those which are listed in the data field of JIG Annex C.

Material/Substance Information	Format 1 (Standard Type)	Format 2 (Detailed Type)
<p>1) Content flag by threshold level * (Y: Yes, N: No)</p> <p>Required for Level A and B both.</p>		<p>Answer Y or N whether a material/substance category exceeding the threshold level is contained in the product. (See Exhibit 1 “Flow Chart for Content Flag by Threshold Level.”) The threshold level is set in both Annexes A and B for each chemical substance category. Annex A: “Intentionally added” or “xxx ppm in a numerical value or intentionally added” Annex B: “1000ppm” (content rate against the mass of the surveyed item)</p> <p><u>Material/substance category in Annex A. (Level A):</u></p> <p><u>1. In the case of a substance category in which the threshold level is set in a numerical value</u></p> <p>(1) Intentionally added: Regarded as contained (Select Y). (2) Not intentionally added but the content in a homogeneous material is greater than the threshold level due to other reasons (Note 1): Regarded as contained (Select Y). (3) Not intentionally added but the content in a homogeneous material is equal to or less than the threshold level due to other reasons (Note 1): Regarded as not contained (Select N).</p> <p>(Note 1) “Other reasons” refer to cases where Level A materials/substances are not intentionally added but where they derived from impurities in natural resources, residuals of manufacturing processes, contamination or use of recycled materials.</p> <ul style="list-style-type: none"> - In the case of “intentionally added,” enter the necessary information in columns 2)-5) below regardless of the content value. - In the case of “not intentionally added but the content rate in a homogeneous material is greater than the threshold level value due to other reasons,” enter the necessary information in columns 2)-5) below. <div style="border: 1px solid black; padding: 5px; margin: 10px 0;"> <p>Even if the content rate is equal to or less than the threshold level, complete these columns if the item clearly contains Level A substances. The purpose of this is to maintain a smooth information flow among the supply chain, which allows us to avoid the need of a resurvey.</p> </div> <div style="border: 1px solid black; padding: 5px; margin: 10px 0;"> <p>The threshold of cadmium defined in the RoHS Directive is 100ppm. If the content rate of cadmium in metals such as brass and zinc alloy is equal to or less than 100ppm, it can be indicated so in 5) “Additional information on material composition of products” column. This avoids the need of a resurvey to achieve compliance with the RoHS Directive.</p> </div> <p><u>2. In the case of a substance category in which the threshold level is not set in a numerical value</u></p> <ul style="list-style-type: none"> - Intentionally added: Regarded as contained (Select Y). - Not intentionally added: Regarded as not contained (Select N). <ul style="list-style-type: none"> - In the case of “intentionally added,” enter the necessary information in columns 2)-5) below regardless of the content value. - In the case of “not intentionally added,” it is not required to report the content value but voluntary reporting is welcomed. If this is the case, enter the necessary information in columns 2)-5) below. <p><u>Material/substance category in Annex B. (Level B):</u></p> <p>(1) If the content rate in product/subpart mass is greater than the threshold level: Regarded as contained. (Select Y). (2) If the content in product/subpart mass is equal to or less than the threshold level: Regarded as not contained. (Select N).</p> <ul style="list-style-type: none"> - If the content rate is greater than the threshold level, enter the necessary information in columns 2)-5) below. <div style="border: 1px solid black; padding: 5px; margin: 10px 0;"> <p>In the case of Level B substance category, the threshold level denominator is per subpart and even if the content rate per material is greater than 1000ppm, it may be equal to or less than 1000ppm if the content rate is based on per subpart. If the item clearly contains Level B substances, answer all columns in the same manner as selecting Y. The purpose of this is to maintain a smooth information flow among the supply chain, which allows us to avoid the need of a resurvey.</p> </div>

<p>1) Content flag by threshold level * (Y: Yes, N: No)</p> <p>(Continued)</p>	<p>Note): When reporting polyvinyl chloride (PVC) in Annex B, answer only whether it exceeds the threshold or not (Y/N). There is no need for reporting the content amount.</p>	
<p>2) Content (mg)*</p> <p>If content flag is Y, required for both Levels A and B.</p> <p>(Except PVC)</p>	<p>Format 1 (Standard Type)</p> <p>(3) Enter in mg and two significant digits (round the third digit) the <u>total content</u> of chemical substances contained per survey unit as set by item 11).</p> <p>- The known maximum content should be entered, in principle. - The metal compound content should be converted to the metal element content contained in compounds instead of the amount of contained compounds. (See Exhibit 4 “Metal Conversion Factor”).</p>	<p>Format 2 (Detailed Type)</p> <p>(3) Enter in mg and two significant digits (round the third digit) the <u>content</u> of chemical substances <u>per application area</u> per survey unit as set by item 11).</p> <p>Note): If chemical substances are contained in several application areas, add a line and enter the content per application area on each line.</p>
<p>3) Intended use classification, intended use, application areas*</p> <p>If content flag is Y, required for both Levels A and B.</p>	<p>Format 1 (Standard Type)</p> <p><u>Enter “*” in applicable items of the “intended use classification” column. If chemical substances are contained in several application areas, enter “*” in all applicable items of the “Intended use classification” column.</u> (See Exhibit 2 and Exhibit 3)</p> <p>When appropriate intent use classification is not listed, select other intended use such as Cd-J-0, then input the details at 5. (Additional information on material composition of products).</p> <p>- Briefly explain the intentions of using chemical substances in the “intended use” column. Example 1) Stabilizer, plasticizer, colorant, flame retardant, anti-rust agent, soldering Example 2) Main constituent, to increase thermostability, to enhance electric properties, to improve mechanical properties</p> <p>- An application area refers to an area among the constituent components of subparts that contains surveyed chemical substances. The name of an application area should be a generic name that is used in specifications and drawings or used by vendors.</p> <p>If the same chemical substance is contained in several application areas, enter major application areas only. If this is the case, indicate “etc.” at the end.</p> <p>- If the surveyed item is a single electronic subpart or other product, the application area should be indicated in the block diagram, material composition list, etc. of this subpart. (See Exhibit 4)</p> <p>Examples 1)-3) are shown below.</p> <p>Format 1 (Standard Type)</p> <p>Example 1) Ceramic materials and internal and external electrode materials in the laminated ceramic capacitor</p> <p>Example 2) Lead wire, electrolytic solution, sealant and electrode foil in the electrolytic capacitor</p> <p>Example 3) Rubber contact point, spring and plastic cover in the switch</p> <p>- If the surveyed item is a device/equipment or electronic assembly subpart, the application area should be indicated in the block diagram, subparts list, etc. of this device or subpart.</p> <p>e.g.) Laminated ceramic capacitor, electrolytic capacitor, printed circuit board, assembling solder</p>	<p>Format 2 (Detailed Type)</p> <p><u>Select an applicable “intended use classification” per application area.</u> (See Exhibit 2 and Exhibit 3)</p> <p>Note): Indicate the application area by showing the homogeneous materials.</p>

	Format 1 (Standard Type)	Format 2 (Detailed Type)
<p>4) Content rate (ppm)*</p> <p>- For both Formats 1 (Standard Type) and 2 (Detailed Type), reporting of only the content rate of Level A substances is required.</p>	<p>Enter the content rate (ppm) in a homogeneous material found in the area containing chemical substances for both Levels A and B.</p> <p>Note): Be aware that the calculation criteria for obtaining Level B substance content rate differ from those for determining the content flag (Y/N) by threshold level. For example, the content flag for some Level B substances may be N even if the content rate is 5000 ppm. For level B substances, reporting of content rate is not required.</p> <p>Note): If the same intended use classification applies to several application areas, enter the <u>maximum value</u>.</p>	<p>Note): If chemical substances are contained in several application areas, add a line and enter the content per application area on each line.</p>
<p>5) Additional information on material composition of products*</p>	<p>Enter additional information on material composition of products if any.</p> <p>e.g.)</p> <ul style="list-style-type: none"> - CAS No. and ISO No. of materials/substances - Alternative plans, reduction plans - Information on radioactivity must be reported. For example, radioactivity isotope name and code, max activity level (MBq), typical activity level (MBq). 	

6. Response Methods and Survey Response Format (Data Format)

The JGPSSI has established rules and requirements for arranging data and other information when answering a green procurement survey, and has developed a survey response format (data format, see Exhibit 6). In principle, all survey responses should be exchanged via electronic data (JGP1 or JGP2 file) based on JGPSSI's survey response format (data format). We also provide free software containing two types of survey response tools that help respondents create JGP1 or JGP2 file in accordance with our survey response format (data format). It is acceptable to reply to a survey by creating JGP1 or JGP2 file without using these survey response tools.

Please see "Survey Response Tool Ver.3 Operation Manual" for how to create response data using these survey response tools.

7. Formats for Handwritten Response

As explained in section 6 above, while in principle the survey response presupposes the exchange of JGP1 or JGP2 files, the JGPSSI also provides formats for handwritten response (see Exhibits 7, 8). These formats are an alternative for those who are unable to utilize the electronic formats (JGP1 or JGP2). Exhibits 7 or 8 may be copied and used when making a handwritten response.

For handwritten response, Format 1 (Standard Type) and Format 2 (Detailed Type) are available. Circle the applicable content flag (Y/N), and in each column of the "Contained substances – Detailed information" section, fill out the information regarding intended use classification, intended use, application areas, content rate and additional information regarding the material composition of products.

For how to use and fill out these formats, please follow the instructions in this manual. Note that the formats for handwritten response are only provided in PDF form as shown in this manual's exhibits. Please do not change the survey items.

8. Operation Flow

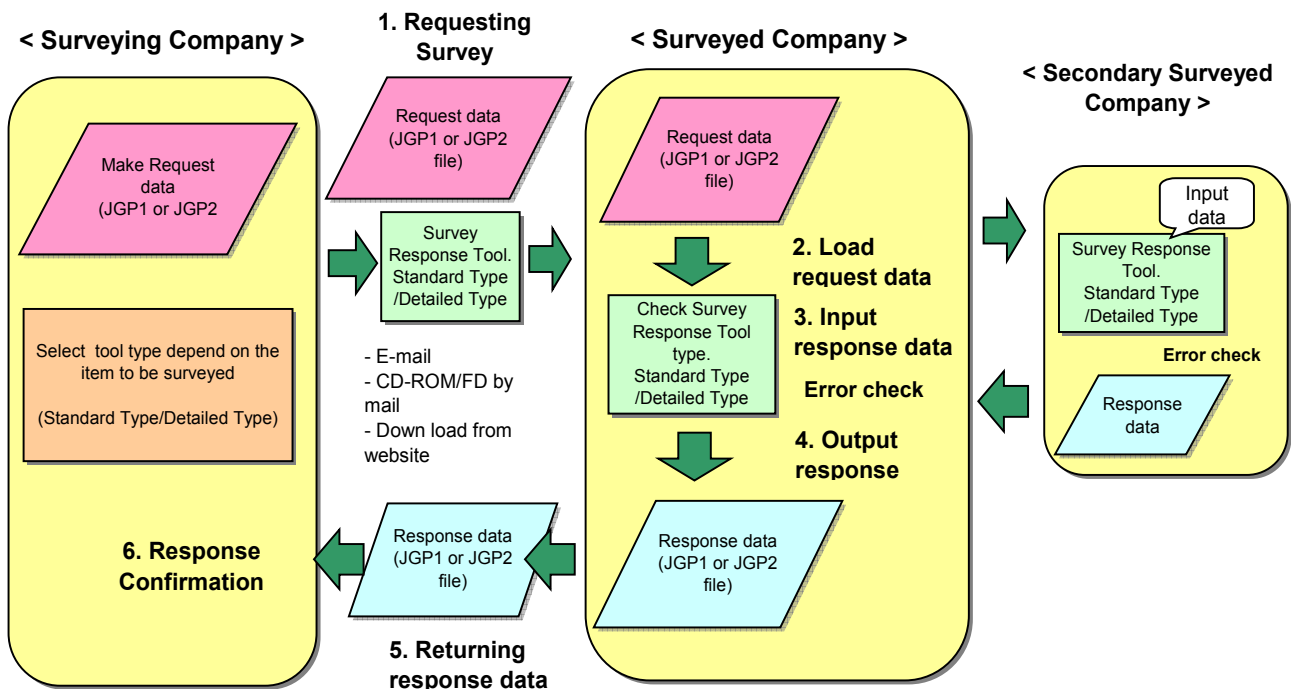

Note: Preparing response data without using the survey tool is permitted.

9. Supplementary

- JIG Annex C: The “Additional information on product/subpart” column in the data field group is not used in the JGPSSI survey and response format.

10. Attachments

Annex A: Survey Substance List (Level A JIG 101)

Classification No.(JGPSSI)	Material/Substance Category	Threshold level
C01	Asbestos	Intentionally added
C02	Certain Azocolourants and Azodyes	Intentionally added (see Directive 76/769/EEC for applicability)
A05	Cadmium /Cadmium Compounds	75 ppm or Intentionally added
A07	Hexavalent Chromium/Hexavalent Chromium Compounds	1000 ppm or Intentionally added
A09	Lead/Lead Compounds	1000 ppm or Intentionally added 300 ppm (PVC cables only)
A10	Mercury/Mercury Compounds	1000 ppm or Intentionally added
C04	Ozone Depleting Substances (CFCs, HCFCs, HBFCs, carbon tetrachloride, etc.)	Class I: Intentionally added Class II. HCFCs: 1000 ppm
B02	Polybrominated Biphenyls (PBBs)	1000 ppm or Intentionally added
B03	Polybrominated Diphenylethers (PBDEs)	1000 ppm or Intentionally added
B05	Polychlorinated Biphenyls (PCBs)	Intentionally added
B06	Polychlorinated Naphthalenes (more than 3 chlorine atoms)	Intentionally added
C06	Radioactive Substances	Intentionally added
B09	Certain Shortchain Chlorinated Paraffins (See Exhibit 5 in this manual)	Intentionally added
A18	Tributyl Tin (TBT) and Triphenyl Tin (TPT)	Intentionally added
A17	Tributyl Tin Oxide (TBTO)	Intentionally added

Annex B: Survey Substance List (Level B JIG 101)

Classification No.(JGPSSI)	Material/Substance Category	Threshold level
A01	Antimony/Antimony Compounds	1000ppm
A02	Arsenic/Arsenic Compounds	1000ppm
A03	Beryllium/Beryllium Compounds	1000ppm
A04	Bismuth/ Bismuth Compounds	1000ppm
B08	Brominated Flame Retardants (other than PBBs or PBDEs)	1000ppm
A11	Nickel (external applications only)	1000ppm
C05	Certain Phthalates (See Exhibit 5 in this manual)	1000ppm
A13	Selenium/Selenium Compounds	1000ppm
B07	Polyvinyl Chloride (PVC) (Disclosure is limited to "is present"/"is not present" in amounts that exceed threshold)	1000ppm

Exhibit 1. Flow Chart for Content Flag by threshold level

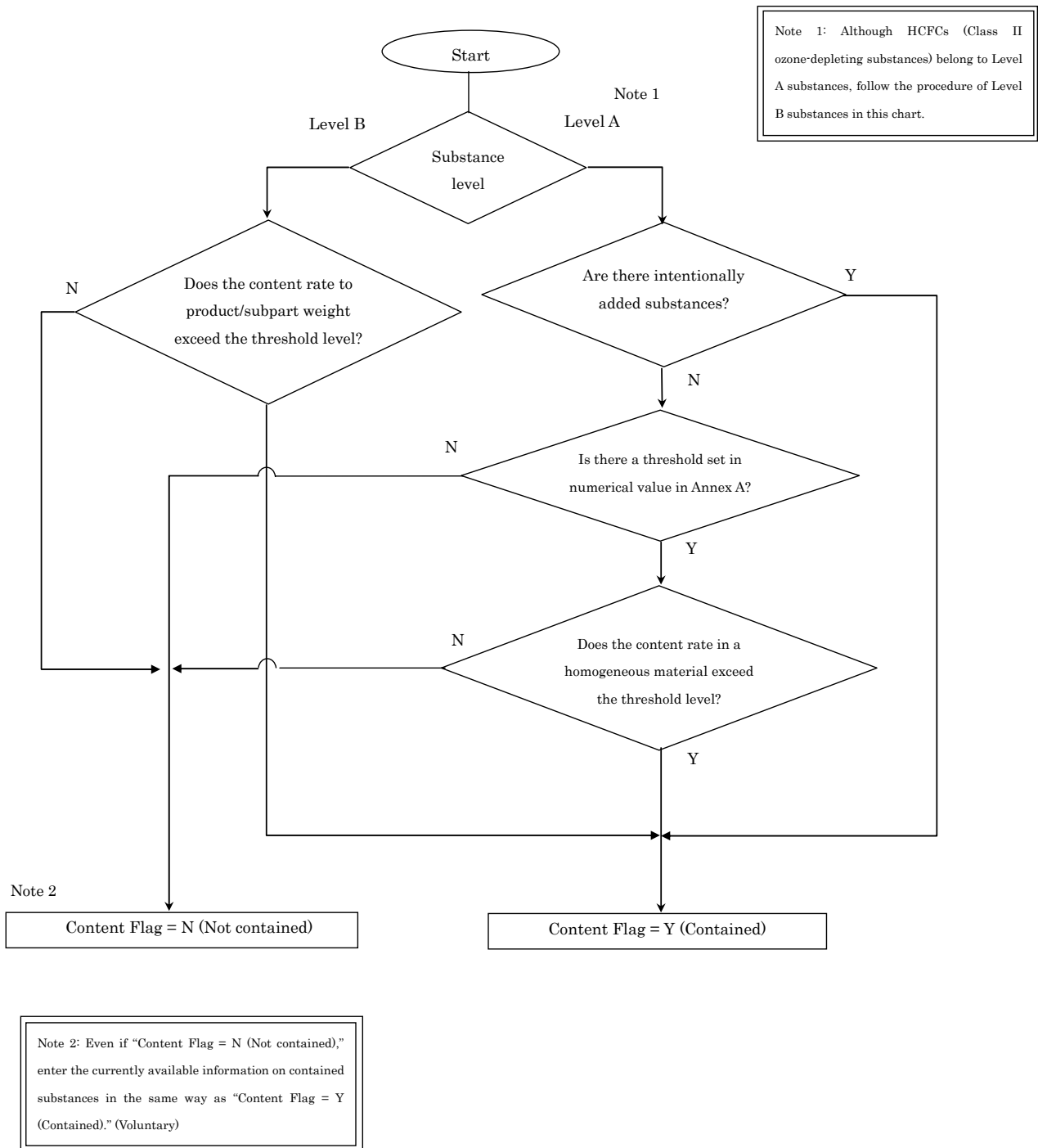

Exhibit 2. Intended use classification List (Four Heavy Metals)

Surveyed Chemical Substance	Relevant Regulations		Code	Intended use classification
	RoHS	ELV		
Cadmium	---	---	Cd-J-99	Containing cadmium above 75ppm : Impurities/recycled materials/contamination
	---	---	Cd-J-0	Other intended use containing cadmium above 75ppm (Explain details in another column)
	0	---	Cd-R-0	Other intended use containing 75ppm or less of cadmium (Explain details in another column)
	0		Cd-R-1	Electric point and plating excluding uses banned by the amended EURO Directive 76/769/EEC *91/338/EEC*
	0		Cd-R-2	Optical glass, filter glass
	0		Cd-R-3	Cadmium in printing inks for the application of enamels on borosilicate glass.
		0	Cd-E-1	Thick film pastes
		0	Cd-E-2	Batteries for electric vehicles
		0	Cd-E-3	Optical components on glass used for Driver Assistance Systems
		0	Cd-RE-98	Containing 75ppm or less of cadmium : Impurities/recycled materials/contamination
Hexavalent chromium	---	---	Cr-J-99	Containing hexavalent chromium above 1000ppm : Impurities/recycled materials/contamination
	---	---	Cr-J-0	Other intended use containing hexavalent chromium above 1000ppm (Explain details in another column)
	0	---	Cr-R-0	Other intended use containing 1000ppm or less of hexavalent chromium (Explain details in another column)
	0		Cr-R-1	For the prevention of corrosion of carbon steel cooling system in absorption refrigerators
	0		Cr-R-2	Hexavalent chromium in corrosion preventive coatings of unpainted metal sheetings and fasteners used for corrosion protection and Electromagnetic Interference Shielding in equipment falling under category three of Directive 2002/96/EC (IT and telecommunications equipment). Exemption granted until 1 July 2007.
		0	Cr-E-1	Anti-corrosion coatings
		0	Cr-E-2	Corrosion preventive coating related to bolt and nut assemblies for chassis applications
		0	Cr-E-3	(Absorption) refrigerators in motor caravans
		0	Cr-RE-98	Containing 1000ppm or less of hexavalent chromium : Impurities/recycled materials/contamination
	Lead	---	---	Pb-J-99
---		---	Pb-J-1	Containing lead above 300ppm , for use in vinyl chloride wires
---		---	Pb-J-0	Other intended use containing lead above 1000ppm (Explain details in another column)
0		---	Pb-R-0	Other intended use containing 1000ppm or less of lead (Explain details in another column)
0		0	Pb-RE-1	Glass used in CRT, electronic parts, and fluorescent tubes
0		0	Pb-RE-2	Electronic ceramic parts
0		0	Pb-RE-3	Steel materials containing less than 0.35% lead by weight (including zinc plating, free-machining steel)
0		0	Pb-RE-4	Copper alloy containing 4% or less of lead by weight (e.g. brass, phosphor bronze)
0			Pb-R-1	Aluminum materials containing 0.4% or less of lead by weight
0			Pb-R-2	High-melting point solder (lead alloy containing above 85% of lead by weight)
0			Pb-R-3	Soldering for servers, storage and storage array systems, and network infrastructure equipment for switching, signaling, transmission and network management for telecommunication
0			Pb-R-4	Compliant pins/connectors
0			Pb-R-5	Coating material for thermal conduction module C-rings
0			Pb-R-6	Optical glass, filter glass
0			Pb-R-7	Solder consisting of more than two types of elements for connecting microprocessor pins and packages containing less than 85wt% and more than 80wt% of lead
0			Pb-R-8	Solder for connecting semiconductor dies and carriers in flip chip IC packages
0			Pb-R-9	Lead-bronze bearing shells and bushes
0			Pb-R-10	Lead in linear incandescent lamps with silicate coated tubes.
0			Pb-R-11	Lead halide as radiant agent in High Intensity Discharge(HID) lamps used for professional reprography applications.
0			Pb-R-12	Lead as activator in the fluorescent powder (1% lead by weight or less) of discharge lamps when used as sun tanning lamps containing phosphors such as BSP (BaSi2O5.Pb) as well as when used as specialty lamps for diazo-printing reprography, lithography, insect traps, photochemical and curing processes containing phosphors such as SMS ((Sr, Ba)2MgSi2O7.Pb).
0			Pb-R-13	Lead with PbBiSn-Hg and PbInSn-Hg in specific compositions as main amalgam and with PbSn-Hg as auxiliary amalgam in very compact Energy Saving lamps (ESL).
0			Pb-R-14	Lead oxide in glass used for bonding front and rear substrates of flat fluorescent lamps used for Liquid Crystal Displays (LCD).
0			Pb-R-15	Lead in printing inks for the application of enamels on borosilicate glass.
0			Pb-R-16	Lead as impurity in RIG (rare earth iron garnet) Faraday rotators used for fibre optic communications systems.
0			Pb-R-17	Lead in finishes of fine pitch components other than connectors with a pitch of 0.65 mm or less with NiFe lead frames and lead in finishes of fine pitch components other than connectors with a pitch of 0.65 mm or less with copper lead-frames.
0			Pb-R-18	Lead in solders for the soldering to machined through hole discoidal and planar array ceramic multilayer capacitors.
0			Pb-R-19	Lead oxide in plasma display panels (PDP) and surface conduction electron emitter displays (SED) used in structural elements; notably in the front and rear glass dielectric layer, the bus electrode, the black stripe, the address electrode, the barrier ribs, the seal frit and frit ring as well as in print pastes.
0			Pb-R-20	Lead oxide in the glass envelope of Black Light Blue (BLB) lamps.
0			Pb-R-21	Lead alloys as solder for transducers used in high-powered (designated to operate for several hours at acoustic power levels of 125 dB SPL and above) loudspeakers.
0			Pb-R-22	Lead bound in crystal glass as defined in Annex I (Categories 1,2,3 and 4) of Council Directive 69/493/EEC.
		0	Pb-E-1	Aluminum for machining purposes (0.4<Pb≤1.5wt%)
		0	Pb-E-2	Aluminum for mechanical processing (Pb≤0.4wt%)
		0	Pb-E-3	bearing shells and bushes (alloy)
	0	Pb-E-4	Batteries	
	0	Pb-E-5	Vibration dampers	
	0	Pb-E-6	Vulcanising agents and stabilisers for elastomers in fluid handling and powertrain applications containing up to 0.5% lead by weight	
	0	Pb-E-7	Bonding agents for elastomers in powertrain applications containing up to 0.5% lead by weight	
	0	Pb-E-8	Solder for electronic boards and other electric parts	
	0	Pb-E-9	Copper in friction materials of brake linings containing more than 0.4% lead by weight	
	0	Pb-E-10	Valve seats	
	0	Pb-E-11	Pyrotechnic initiators	
	0	Pb-RE-98	Containing 1000ppm or less of lead : Impurities/recycled materials/contamination	
Mercury	---	---	Hg-J-99	Containing 1000ppm or more of mercury: Impurities/recycled materials/contamination
	---	---	Hg-J-0	Other intended use containing 1000ppm or more of mercury (Explain details in another column)
	0	---	Hg-R-0	Other intended use containing less than 1000ppm of mercury (Explain details in another column)
	0		Hg-R-1	Mercury in compact fluorescent lamps not exceeding 5mg per lamp
	0		Hg-R-2	Mercury in straight fluorescent lamps for general purposes not exceeding each threshold
	0		Hg-R-3	Straight fluorescent lamps for special purposes
	0		Hg-R-4	Other lamps
		0	Hg-E-1	Discharge lamps, instrument panel displays
	0	Hg-RE-98	Containing 1000ppm or less of mercury : Impurities/recycled materials/contamination	

* Middle letter code represents following:

R: EU/RoHS
E: EU/ELV
J: JGPGSSI

Exhibit 3. Intended use classification List (Level A : Others)

Surveyed Chemical Substance	Relevant Regulations		Code	Intended use classification
	RoHS	ELV		
Tributyl Tin Oxide (TBTO)	---	---	A17-J-1	For wet areas (Used in the kitchen or bathroom)
	---	---	A17-J-2	Printing ink, antiseptic, mildew proof agent, underwater paint, etc.
	---	---	A17-J-0	Other
Tributyl Tins & Triphenyl Tins	---	---	A18-J-1	For wet areas (Used in the kitchen or bathroom)
	---	---	A18-J-2	Printing ink, antiseptic, mildew proof agent, underwater paint, etc.
	---	---	A18-J-0	Other
Polybrominated Biphenyls (PBBs)	---	---	B02-J-99	Containing PBB above 1000ppm : Impurities/recycled materials/contamination
	---	---	B02-J-0	Other intended use containing PBB above 1000ppm (Explain details in another column)
	O		B02-R-0	Other intended use containing 1000ppm or less of PBB (Explain details in another column)
	O		B02-R-98	Containing less than 1000ppm of PBB: Impurities/recycled materials/contamination
Polybrominated Diphenyl ethers (PBDEs)	---	---	B03-J-99	Containing 1000ppm or more of PBDE: Impurities/recycled materials/contamination
	---	---	B03-J-0	Containing 1000ppm or more of PBDE, other intended use (Explain details in another column)
	O		B03-R-0	Other intended use containing 1000ppm or less of PBDE (Explain details in another column)
	O		B03-R-1	DecaBDE in polymeric applications
	O		B03-R-98	Containing less than 1000ppm of PBDE: Impurities/recycled materials/contamination
Polychlorinated Biphenyls (PCBs)	---	---	B05-J-0	All
Polychloronaphthalenes (Cl ³)	---	---	B06-J-0	All
Short Chain Chlorinated Paraffins	---	---	B09-J-0	All
Asbestos	---	---	C01-J-0	All
Azo Colorants	---	---	C02-J-1	Leather and textile products that come in continuous contact with human body
	---	---	C02-J-0	Other
Ozone Depleting Substances	---	---	C04-J-99	Impurities/recycled materials/contamination containing Class II ozone depleting substances or HCFCs above 1000ppm
	---	---	C04-J-0	All Class I substances (Explain details in another column)
			C04-J-98	Impurities/recycled materials/contamination containing 1000ppm or less of Class II ozone depleting substances or HCFCs
Radioactive Substances	---	---	C06-J-0	All

* Middle letter code represents following:
R: EU/RoHS
J: JGPSSI

Intended use classification List (Level B)

Surveyed Chemical Substance	Code	Intended use classification
Antimony and Antimony Compounds	Sb-J-0	All
Arsenic and Arsenic Compounds	As-J-0	All
Beryllium and Beryllium Compounds	Be-J-0	All
Bismuth and Bismuth Compounds	Bi-J-0	All
Nickel	Ni-J-0	All
Selenium and Selenium Compounds	Se-J-0	All
Vinyl Chloride Polymer (PVC)	B07-J-0	All
Brominated Flame Retardants	B08-J-0	All
Phthalates	C05-J-0	All

* Middle letter code represents following:
J: JGPSSI

Exhibit 4. Examples of Application Areas

The following are example names of application areas that serve as references when completing the “application area” column of the survey.

Note: These examples do not represent all the application areas.

If using Format 2, enter the name of the application area so that the homogeneous material is clearly stated.

E.g. lead terminal plating (see Component Part Example 5).

[Component Part Example 1] Aluminum electrolytic capacitor

Component parts: Sleeve, Case, Internal Element, Electrolytic Solution, Lead Terminal

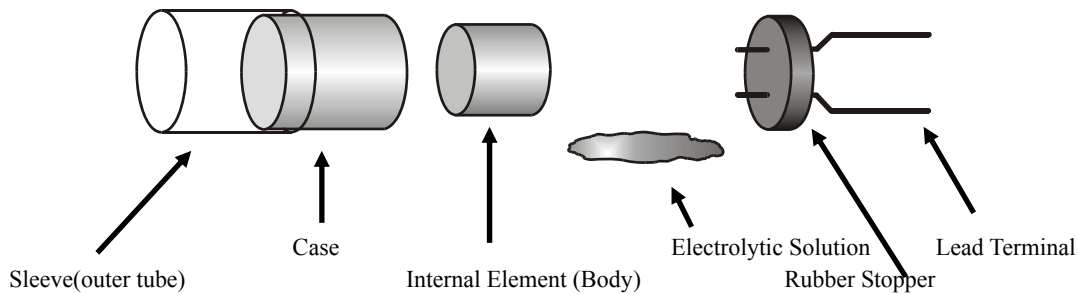

[Component Part Example 2] Connectors

Component parts: Housing and contacts

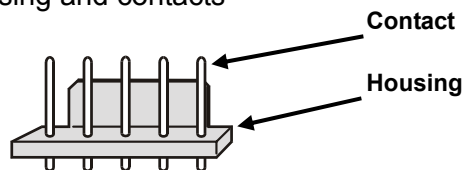

[Component Part Example 3] Switches, relays, and other parts with mechanical components

Component parts: Part case (molded plastic etc.), metal components (lever, frame, terminals, etc.), moving part (contact points, etc.)

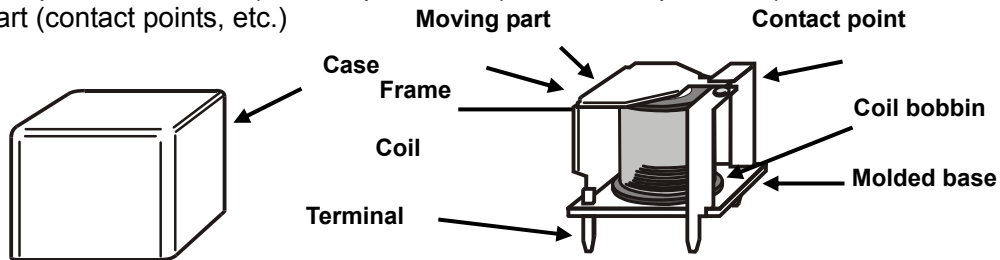

* Please pay particular attention to special metals (alloys) used for plastic flame retardants, and electrical characteristics and lubrication of contact points.

[Component Part Example 4] Surface-mounted chip parts

Component parts: Terminal and main body

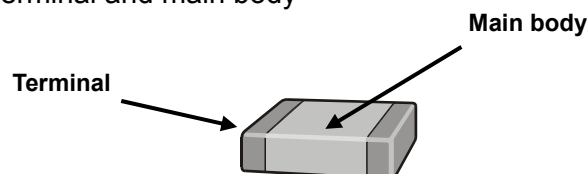

* The main body of the part is made of multiple materials and the substance concerned is present, break it down.
e.g.) Part (main body) → ceramic and internal electrode

[Component Part Example 5] Semiconductor devices

Component parts: Lead terminal (lead frame, etc.), package main body (molded plastic, etc.), and device chip

Outward appearance:

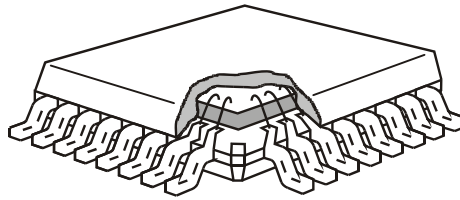

Cross section:

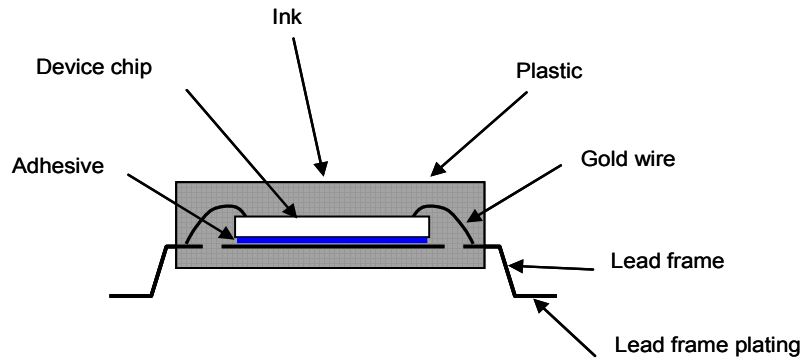

- * Please pay particular attention to any flame retardants in the package plastic, and the lead material and treatment
- * Make the response concerning the device chip as best you can

[Component Part Example 6] Transformers and inductors

Component parts: Core, coil, bobbin, lead wire, insulator, case frame, etc.

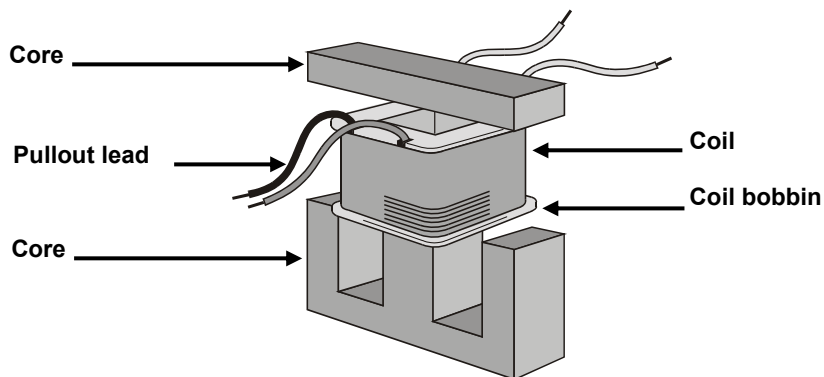

- * Pay particular attention to flame retardants in plastic materials or insulating parts, impregnant in the coil, PVCs or flame retardants in the lead wire.

[Component Part Example 7] DC motors

Component parts: Part case (molded plastic, etc.), metal parts (shaft, rotor core, terminal, frame, etc.) brush, magnet, coil, and other

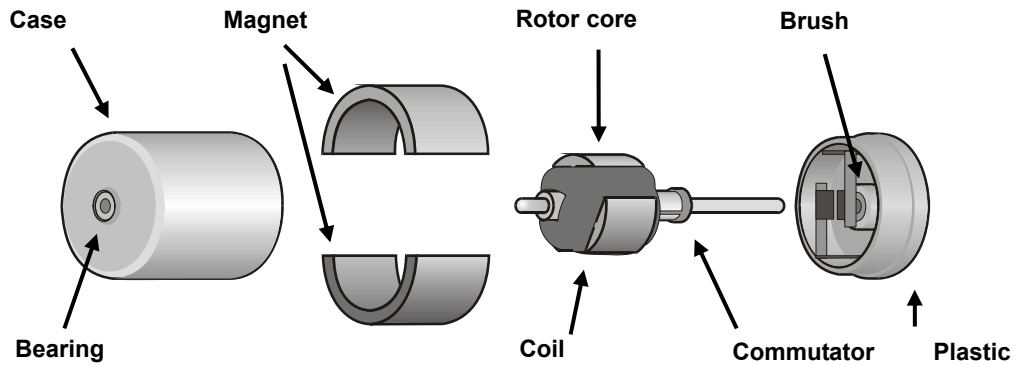

- * Pay particular attention to special metals (alloys) used for flame retardants in plastic, and electrical characteristics and lubrication in commutators, as well as grease in bearings.
- * Calculate the amount contained per part from the amounts contained in each of the part components, when the substance is contained in lead wire and electronic circuits.

[Component Part Example 8] Electrical cable (power cord)

Component parts: Conductor, plating, insulator (interior coating), and jacket (exterior coating)

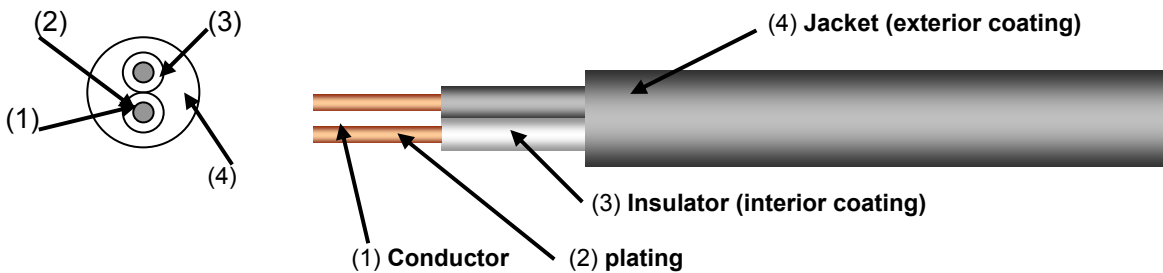

Exhibit 5. JIG Detailed Chemical lists (with metal conversion factor)

Classification	JGPSSI Classification No.	Substance group	Substance name	Metal Conversion Factor	CAS No.	
Level A						
	C01	Table A : Asbestos	Asbestos	-	1332-21-4	
			Actinolite	-	77536-66-4	
			Amosite (Grunerite)	-	12172-73-5	
			Anthophyllite	-	77536-67-5	
			Chrysotile	-	12001-29-5	
			Crocidolite	-	12001-28-4	
			Tremolite	-	77536-68-6	
	C02	Table B : Azo colorants (specific amines)	biphenyl-4-ylamine	-	92-67-1	
			Benzidine	-	92-87-5	
			4-chloro-o-toluidine	-	95-69-2	
			2-naphthylamine	-	91-59-8	
			o-aminoazotoluene	-	97-56-3	
			5-nitro-o-toluidine	-	99-55-8	
			4-chloroaniline	-	106-47-8	
			4-methoxy-m-phenylenediamine	-	615-05-4	
			4,4'-methylenedianiline	-	101-77-9	
			3,3'-dichlorobenzidine	-	91-94-1	
			3,3'-dimethoxybenzidine	-	119-90-4	
			3,3'-dimethylbenzidine	-	119-93-7	
			4,4'-methylenedi-o-toluidine	-	838-88-0	
			6-methoxy-m-toluidine	-	120-71-8	
			4,4'-methylene-bis(2-chloroaniline)	-	101-14-4	
			4,4'-oxydianiline	-	101-80-4	
			4,4'-thiodianiline	-	139-65-1	
			o-toluidine	-	95-53-4	
			4-methyl-m-phenylenediamine	-	95-80-7	
			2,4,5-trimethylaniline	-	137-17-7	
	o-anisidine	-	90-04-0			
	4-amino azobenzene	-	60-09-03			
	Metal compounds	A05	Table C : Cadmium / Cadmium Compounds	Cadmium	1.000	7440-43-9
				Cadmium oxide	0.875	1306-19-0
				Cadmium sulfide	0.778	1306-23-6
				Cadmium chloride	0.613	10108-64-2
Cadmium sulfate				0.539	10124-36-4	
Other cadmium compounds				-	-	
A07				Table D : Hexavalent Chromium / Hexavalent Chromium Compounds	Chromium (VI) oxide	0.520
		Barium chromate	0.205		10294-40-3	
		Calcium chromate	0.333		13765-19-0	
		Chromium trioxide	0.520		1333-82-0	
		Lead (II) chromate	0.161		7758-97-6	
		Sodium chromate	0.321		7775-11-3	
		Sodium dichromate	0.397		10588-01-9	
		Strontium chromate	0.255		7789-06-2	
		Potassium dichromate	0.353		7778-50-9	
		Potassium chromate	0.268		7789-00-6	
		Zinc chromate	0.287		13530-65-9	
		Other hexavalent chromium compounds	-		-	

Classification	JGPSSI Classification No.	Substance Group	Substance Name	Metal Conversion Factor	CAS No.
Metal compounds	A09	Table E: Lead/Lead Compounds	Lead	1.000	7439-92-1
			Lead(II) sulfate	0.683	7446-14-2
			Lead(II) carbonate	0.775	598-63-0
			Lead hydroxidcarbonate	0.801	1319-46-6
			Lead acetate	0.637	301-04-2
			Lead (II) acetate, trihydrate	0.546	6080-56-4
			Lead phosphate	0.766	7446-27-7
			Lead selenide	0.724	12069-00-0
			Lead (IV) oxide	0.866	1309-60-0
			Lead (II,IV) oxide	0.907	1314-41-6
			Lead (II) sulfide	0.866	1314-87-0
			Lead (II) oxide	0.928	1317-36-8
			Lead(II) carbonate basic	0.801	1319-46-6
			Lead hydroxidcarbonate	0.801	1344-36-1
			Lead(II) phosphate	0.766	7446-27-7
			Lead(II) chromate	0.641	7758-97-6
			Lead(II) titanate	0.686	12060-00-3
			Lead sulfate,sulphuric acid, lead salt	1.000	15739-80-7
			Lead sulphate,tribasic	0.850	12202-17-4
			Lead stearate	0.268	1072-35-1
	Other lead compounds	-	-		
	A10	Table F: Mercury/Mercury Compounds	Mercury	1.000	7439-97-6
			Mercuric chloride	-	33631-63-9
			Mercury (II) chloride	0.739	7487-94-7
			Mercuric sulfate	0.676	7783-35-9
			Mercuric nitrate	0.618	10045-94-0
			Mercuric (II) oxide	0.926	21908-53-2
			Mercuric sulfide	0.862	1344-48-5
			Other mercury compounds	-	-
	C04	Table G: Ozone Depleting Substances /Isomers	Trichlorofluoromethane	-	75-69-4
			Dichlorodifluoromethane (CFC12)	-	75-71-8
			Chlorotrifluoromethane (CFC 13)	-	75-72-9
			Pentachlorofluoroethane (CFC 111)	-	354-56-3
			Tetrachlorodifluoroethane (CFC 112)	-	76-12-0
			Trichlorotrifluoroethane (CFC 113)	-	354-58-5
			1,1,2 Trichloro-1,2,2 trifluoroethane	-	76-13-1
			Dichlorotetrafluoroethane (CFC 114)	-	76-14-2
			Monochloropentafluoroethane (CFC 115)	-	76-15-3
			Heptachlorofluoropropane (CFC 211)	-	422-78-6
Hexachlorodifluoropropane (CFC 212)			-	135401-87-5	
			-	3182-26-1	
Pentachlorotrifluoropropane (CFC 213)			-	165977	
			-	134237-31-3	
Tetrachlorotetrafluoropropane (CFC 214)			-	29255-31-0	
1,1,1,3-Tetrachlorotetrafluoropropane			-	2268-46-4	
Trichloropentafluoropropane (CFC 215)			-	1599-41-3	
1,1,1-Trichloropentafluoropropane			-	4259-43-2	
1,2,3-Trichloropentafluoropropane			-	76-17-5	
Dichlorohexafluoropropane (CFC 216)			-	661-97-2	
Monochloroheptafluoropropane (CFC 217)	-	422-86-6			

Classification	JGPSSI Classification No.	Substance Group	Substance Name	Metal Conversion Factor	CAS No.
			Bromochlorodifluoromethane (Halon 1211)	-	353-59-3
			Bromotrifluoromethane (Halon 1301)	-	75-63-8
			Dibromotetrafluoroethane (Halon 2402)	-	124-73-2
			Carbon Tetrachloride (Tetrachloromethane)	-	56-23-5
			1,1,1, - Trichloroethane (methyl chloroform) and its isomers except 1,1,2-trichloroethane	-	71-55-6
			Bromomethane (Methyl Bromide)	-	74-83-9
			Bromodifluoromethane and isomers (HBFC's)	-	1511-62-2
		Table H: Hydrochlorofluorocarbons / Isomer	Dichlorofluoromethane (HCFC 21)	-	75-43-4
			Chlorodifluoromethane (HCFC 22)	-	75-45-6
			Chlorofluoromethane (HCFC 31)	-	593-70-4
			Tetrachlorofluoroethane (HCFC 121)	-	134237-32-4
			1,1,1,2-tetrachloro-2-fluoroethane (HCFC 121a)	-	354-11-0
			1,1,2,2-tetrachloro-1-fluoroethane	-	354-14-3
			Trichlorodifluoroethane (HCFC 122)	-	41834-16-6
			1,2,2-trichloro-1,1-difluoroethane	-	354-21-2
			Dichlorotrifluoroethane(HCFC 123)	-	34077-87-7
			Dichloro-1,1,2-trifluoroethane	-	90454-18-5
			2,2-dichloro-1,1,1-trifluoroethane	-	306-83-2
			1,2-dichloro-1,1,2-trifluoroethane (HCFC-123a)	-	354-23-4
			1,1-dichloro-1,2,2-trifluoroethane (HCFC-123b)	-	812-04-4
			2,2-dichloro-1,1,2-trifluoroethane (HCFC-123b)	-	812-04-4
			Chlorotetrafluoroethane (HCFC 124)	-	63938-10-3
			2-chloro-1,1,1,2-tetrafluoroethane	-	2837-89-0
			1-chloro-1,1,2,2-tetrafluoroethane (HCFC 124a)	-	354-25-6
			Trichlorofluoroethane (HCFC 131)	-	27154-33-2;(134237-34-6)
			1-Fluoro-1,2,2-trichloroethane	-	359-28-4
			1,1,1-trichloro-2-fluoroethane (HCFC131b)	-	811-95-0
			Dichlorodifluoroethane (HCFC 132)	-	25915-78-0
			1,2-dichloro-1,1-difluoroethane (HCFC 132b)	-	1649-08-7
			1,1-dichloro-1,2-difluoroethane (HFCF 132c)	-	1842-05-3
			1,1-dichloro-2,2-difluoroethane	-	471-43-2
			1,2-dichloro-1,2-difluoroethane	-	431-06-1
			Chlorotrifluoroethane (HCFC 133)	-	1330-45-6
			1-chloro-1,2,2-trifluoroethane	-	1330-45-6
			2-chloro-1,1,1-trifluoroethane (HCFC-133a)	-	75-88-7
		Dichlorofluoroethane(HCFC 141)	-	1717-00-6; (25167-88-8)	
		1,1-dichloro-1-fluoroethane (HCFC-141b)	-	1717-00-6	
		1,2-dichloro-1-fluoroethane	-	430-57-9	
		Chlorodifluoroethane (HCFC 142)	-	25497-29-4	
		1-chloro-1,1-difluoroethane (HCFC142b)	-	75-68-3	
		1-chloro-1,2-difluoroethane (HCFC142a)	-	25497-29-4	
		Hexachlorofluoropropane (HCFC 221)	-	134237-35-7	

Classification	JGPSSI Classification No.	Substance Group	Substance Name	Metal Conversion Factor	CAS No.
			Pentachlorodifluoropropane (HCFC 222)	-	134237-36-8
			Tetrachlorotrifluoropropane (HCFC 223)	-	134237-37-9
			Trichlorotetrafluoropropane (HCFC 224)	-	134237-38-0
			Dichloropentafluoropropane, (Ethyne, fluoro-) (HCFC 225)	-	127564-92-5; (2713-09-9)
			2,2-Dichloro-1,1,1,3,3-pentafluoropropane(HCFC 225aa)	-	128903-21-9
			2,3-Dichloro-1,1,1,2,3-pentafluoropropane (HCFC 225ba)	-	422-48-0
			1,2-Dichloro-1,1,2,3,3-pentafluoropropane (HCFC 225bb)	-	422-44-6
			3,3-Dichloro-1,1,1,2,2-pentafluoropropane (HCFC 225ca)	-	422-56-0
			1,3-Dichloro-1,1,2,2,3-pentafluoropropane (HCFC 225cb)	-	507-55-1
			1,1-Dichloro-1,2,2,3,3-pentafluoropropane(HCFC 225cc)	-	13474-88-9
			1,2-Dichloro-1,1,3,3,3-pentafluoropropane (HCFC 225da)	-	431-86-7
			1,3-Dichloro-1,1,2,3,3-pentafluoropropane (HCFC 225ea)	-	136013-79-1
			1,1-Dichloro-1,2,3,3,3-pentafluoropropane(HCFC 225eb)	-	111512-56-2
			Chlorohexafluoropropane (HCFC 226)	-	134308-72-8
			Pentachlorofluoropropane (HCFC 231)	-	134190-48-0
			Tetrachlorodifluoropropane (HCFC 232)	-	134237-39-1
			Trichlorotrifluoropropane (HCFC 233)	-	134237-40-4
			1,1,1-Trichloro-3,3,3-trifluoropropane	-	7125-83-9
			Dichlorotetrafluoropropane (HCFC 234)	-	127564-83-4
			Chloropentafluoropropane (HCFC 235)	-	134237-41-5
			1-Chloro-1,1,3,3,3-pentafluoropropane	-	460-92-4
			Tetrachlorofluoropropane (HCFC 241)	-	134190-49-1
			Trichlorodifluoropropane (HCFC 242)	-	134237-42-6
			Dichlorotrifluoropropane (HCFC 243)	-	134237-43-7
			1,1-dichloro-1,2,2-trifluoropropane	-	7125-99-7
			2,3-dichloro-1,1,1-trifluoropropane	-	338-75-0
			3,3-Dichloro-1,1,1-trifluoropropane	-	460-69-5
			Chlorotetrafluoropropane (HCFC 244)	-	134190-50-4
			3-chloro-1,1,2,2-tetrafluoropropane	-	679-85-6
			Trichlorofluoropropane (HCFC 251)	-	134190-51-5
			1,1,3-trichloro-1-fluoropropane	-	818-99-5
			Dichlorodifluoropropane (HCFC 252)	-	134190-52-6
			Chlorotrifluoropropane (HCFC 253)	-	134237-44-8
			3-chloro-1,1,1-trifluoropropane (HCFC 253fb)	-	460-35-5
			Dichlorofluoropropane (HCFC 261)	-	134237-45-9
			1,1-dichloro-1-fluoropropane	-	7799-56-6

Classification	JGPSSI Classification No.	Substance Group	Substance Name	Metal Conversion Factor	CAS No.
			Chlorodifluoropropane (HCFC 262)	-	134190-53-7
			2-chloro-1,3-difluoropropane	-	102738-79-4
			Chlorofluoropropane (HCFC 271)	-	134190-54-8
			2-chloro-2-fluoropropane	-	420-44-0
	B02 B03	Table I: Polybrominated Biphenyls/Polybrominated Diphenylethers	Bromobiphenyl and its ethers	-	2052-07-5 (2-Bromobiphenyl) 2113-57-7 (3-Bromobiphenyl) 92-66-0 (4-Bromobiphenyl) 101-55-3(ethers)
			Decabromobiphenyl and its ethers	-	13654-09-6 1163-19-5(ethers)
			Dibromobiphenyl and its ethers	-	92-86-4 2050-47-7(ethers)
			Heptabromobiphenylether	-	68928-80-3
			Hexabromobiphenyl and its ethers	-	59080-40-9 36355-01-8 (hexabromo-1,1.-biphenyl) 67774-32-7 (Firemaster FF-1) 36483-60-0(ethers)
			Nonabromobiphenylether	-	63936-56-1
			Octabromobiphenyl and its ethers	-	61288-13-9 32536-52-0(ethers)
			Pentabromobidphenyl ether (note: Commercially available PeBDPO is a complex reaction mixture containing a variety of brominated diphenyloxides.	-	32534-81-9
			Polybrominated Biphenyls	-	59536-65-1
			Tetrabromobiphenyl and its ethers	-	40088-45-7 40088-47-9 (ethers)
			Tribromobiphenyl ether	-	49690-94-0
	B05	Table J: Polychlorinated Biphenyls (PCBs)	Polychlorinated Biphenyls	-	1336-36-3
			Aroclor	-	12767-79-2
			Chlorodiphenyl (Aroclor 1260)	-	11096-82-5
			Kanechlor 500	-	27323-18-8
			Aroclor 1254	-	11097-69-1
			Terphenyls	-	26140-60-3
	B06	Table K: Polychlorinated Naphthalenes	Polychlorinated Naphthalenes	-	70776-03-3
			Other polychlorinated Naphthalenes	-	-
	C06	Table L: Radioactive Substances	Uranium	-	-
			Plutonium	-	-
			Radon	-	-
			Americium	-	-
			Thorium	-	-
			Cesium	-	7440-46-2
			Strontium	-	7440-24-6
			Other radioactive substances	-	-

Classification	JGPSSI Classification No.	Substance Group	Substance Name	Metal Conversion Factor	CAS No.	
	B09	Table M: Short Chain Chlorinated paraffins	Chlorinated paraffins (C10-13) [1]	-	85535-84-8	
			Other Short Chain Chlorinated Paraffins	-	-	
	A17	Table N: Tributyl Tin Oxide	Bis(tri-n-butyltin) oxide	-	56-35-9	
	A18	Table O: Tributyl Tin / Triphenyl Tin	Bis(tri-n-butyltin) oxide	-	56-35-9	
			Triphenyltin N,N'-dimethyldithiocarbamate	-	1803-12-9	
			Triphenyltin fluoride	-	379-52-2	
			Triphenyltin acetate	-	900-95-8	
			Triphenyltin chloride	-	639-58-7	
			Triphenyltin hydroxide	-	76-87-9	
			Triphenyltin fatty acid salts (C=9-11)	-	47672-31-1	
			Triphenyltin chloroacetate	-	7094-94-2	
			Tributyltin methacrylate	-	2155-70-6	
			Bis(tributyltin) fumarate	-	6454-35-9	
			Tributyltin fluoride	-	1983-10-4	
			Bis(tributyltin) 2,3-dibromosuccinate	-	31732-71-5	
			Tributyltin acetate	-	56-36-0	
			Tributyltin laurate	-	3090-36-6	
			Bis(tributyltin) phthalate	-	4782-29-0	
			Copolymer of alkyl acrylate, methyl methacrylate and tributyltin methacrylate(alkyl; C=8)	-	-	
			Tributyltin sulfamate	-	6517-25-5	
			Bis(tributyltin) maleate	-	14275-57-1	
			Tributyltin chloride	-	1461-22-9	
			Mixture of tributyltin cyclopentanecarboxylate and its analogs (Tributyltin naphthenate)	-	-	
	Mixture of tributyltin 1,2,3,4,4a, 4b, 5,6,10,10a-decahydro-7-isopropyl-1, 4a-dimethyl-1-phenanthlenecarboxylate and its analogs (Tributyltin rosin salt)	-	-			
	Other Tributyl Tins & Triphenyl Tins	-	-			
	Level B					
	Metal compounds	A01	Table P: Antimony / Antimony Compounds	Antimony (metallic)	1.000	7440-36-0
Antimony trioxide				0.835	1309-64-4	
Antimony pentoxide				0.753	1314-60-9	
Antimony trichloride				0.534	10025-91-9	
Sodium antimonate				0.632	15432-85-6	
Other antimony compounds				-	-	
A02		Table Q: Arsenic / Arsenic Compounds	Arsenic	1.000	7440-38-2	
			Gallium arsenide	0.518	1303-00-0	
			Calcium arsenate	0.419	7778-44-1	
			Calcium arsenite	0.409	27152-57-4	
			Arsenic pentoxide	0.652	1303-28-2	
			Arsenic trioxide	0.757	1327-53-3	
			Potassium arsenite	0.513	10124-50-2	
			Potassium arsenate	0.416	7784-41-0	
			Lead arsenate	0.167	3687-31-8	
			Other arsenic compounds	-	-	

Classification	JGPSSI Classification No.	Substance Group	Substance Name	Metal Conversion Factor	CAS No.
Metal compounds	A03	Table R : Beryllium / Beryllium Compounds	Beryllium	1.000	7440-41-7
			Beryllium-aluminum alloy	-	12770-50-2
			Beryllium chloride	0.113	7787-47-5
			Beryllium fluoride	0.192	7787-49-7
			Beryllium hydroxide	0.210	13327-32-7
			Beryllium oxide	0.360	1304-56-9
			Beryllium phosphate	0.145	13598-15-7
			Beryllium sulfate	0.086	13510-49-1
			Beryllium sulfate tetrahydrate	0.051	7787-56-6
			Beryl ore	0.050	1302-52-9
			Other beryllium compounds	-	-
	A04	Table S : Bismuth / Bismuth Compounds	Bismuth	1.000	7440-69-9
			Bismuth trioxide	0.897	1304-76-3
			Bismuth nitrate	0.529	10361-44-1
			Other bismuth compounds	-	-
	B08	Table T : Brominated flame retardant (other than PBBs, PBDEs)	Brominated flame retardant which comes under notation of ISO 1043-4 code number FR(14)[Aliphatic/alicyclic brominated compounds]	-	-
			Brominated flame retardant which comes under notation of ISO 1043-4 code number FR(15)[Aliphatic/alicyclic brominated compounds in combination with antimony compounds]	-	-
			Brominated flame retardant which comes under notation of ISO 1043-4 code number FR(16)[Aromatic brominated compounds excluding brominated diphenyl ether and biphenyls]	-	-
			Brominated flame retardant which comes under notation of ISO 1043-4 code number FR(17)[Aromatic brominated compounds excluding brominated diphenyl ether and biphenyls] in combination with antimony compounds]	-	-
Brominated flame retardant which comes under notation of ISO 1043-4 code number FR(22)[Aliphatic/alicyclic chlorinated and brominated compounds]			-	-	
Brominated flame retardant which comes under notation of ISO 1043-4 code number FR(42)[Brominated organic phosphorus compounds]			-	-	
Poly(2,6-dibromo-phenylene oxide)			-	69882-11-7	
Tetra-decabromo-diphenoxy-benzene			-	58965-66-5	
1,2-Bis(2,4,6-tribromo-phenoxy) ethane			-	37853-59-1	
3,5,3',5'-Tetrabromo-bisphenol A (TBBA)			-	79-94-7	
TBBA, unspecified			-	30496-13-0	
TBBA-epichlorhydrin oligomer			-	40039-93-8	
TBBA-TBBA-diglycidyl-ether oligomer			-	70682-74-5	

Classification	JGPSSI Classification No.	Substance Group	Substance Name	Metal Conversion Factor	CAS No.
			TBBA carbonate oligomer	-	28906-13-0
			TBBA carbonate oligomer, phenoxy end capped	-	94344-64-2
			TBBA carbonate oligomer, 2,4,6-tribromo-phenol terminated	-	71342-77-3
			TBBA-bisphenol A-phosgene polymer	-	32844-27-2
			Brominated epoxy resin end-capped with tribromophenol	-	139638-58-7
			Brominated epoxy resin end-capped with tribromophenol	-	135229-48-0
			TBBA-(2,3-dibromo-propyl-ether)	-	21850-44-2
			TBBA bis-(2-hydroxy-ethyl-ether)	-	4162-45-2
			TBBA-bis-(allyl-ether)	-	25327-89-3
			TBBA-dimethyl-ether	-	37853-61-5
			Tetrabromo-bisphenol S	-	39635-79-5
			TBBS-bis-(2,3-dibromo-propyl-ether)	-	42757-55-1
			2,4-Dibromo-phenol	-	615-58-7
			2,4,6-tribromo-phenol	-	118-79-6
			Pentabromo-phenol	-	608-71-9
			2,4,6-Tribromo-phenyl-allyl-ether	-	3278-89-5
			Tribromo-phenyl-allyl-ether, unspecified	-	26762-91-4
			Bis(methyl)tetrabromo-phthalate	-	55481-60-2
			Bis(2-ethylhexyl)tetrabromo-phthalate	-	26040-51-7
			2-Hydroxy-propyl-2-(2-hydroxy-ethoxy)-ethyl-TBP	-	20566-35-2
			TBPA, glycol-and propylene-oxide esters	-	75790-69-1
			N,N'-Ethylene -bis-(tetrabromo-phthalimide)	-	32588-76-4
			Ethylene-bis(5,6-dibromo-norbornane-2,3-dicarboximide)	-	52907-07-0
			2,3-Dibromo-2-butene-1,4-diol	-	487270
			Dibromo-neopentyl-glycol	-	3296-90-0
			Dibromo-propanol	-	96-13-9
			Tribromo-neopentyl-alcohol	-	36483-57-5
			Poly tribromo-styrene	-	57137-10-7
			Tribromo-styrene	-	61368-34-1
			Dibromo-styrene grafted PP	-	171091-06-8
			Poly-dibromo-styrene	-	31780-26-4
			Bromo-/Chloro-paraffins	-	68955-41-9
			Bromo-/Chloro-alpha-olefin	-	82600-56-4
			Vinylbromide	-	593-60-2
			Tris-(2,3-dibromo-propyl)-isocyanurate	-	52434-90-9
			Tris(2,4-Dibromo-phenyl) phosphate	-	49690-63-3
			Tris(tribromo-neopentyl) phosphate	-	19186-97-1
			Chlorinated and brominated phosphate ester	-	125997-20-8
			Pentabromo-toluene	-	87-83-2
			Pentabromo-benzyl bromide	-	38521-51-6
			1,3-Butadiene homopolymer,brominated	-	68441-46-3

Classification	JGPSSI Classification No.	Substance Group	Substance Name	Metal Conversion Factor	CAS No.
			Pentabromo-benzyl-acrylate, monomer	-	59447-55-1
			Pentabromo-benzyl-acrylate, polymer	-	59447-57-3
			Decabromo-diphenyl-ethane	-	84852-53-9
			Tribromo-bisphenyl-maleinimide	-	59789-51-4
			Brominated trimethylphenyl-lindane	-	59789-51-4
			Other Brominated Flame Retardants	-	-
			Hexabromo-cyclo-dodecane (HBCD), unspecified	-	3194-55-6
			Tetrabromo-chyclo-octane	-	31454-48-5
			1,2-Dibromo-4-(1,2 dibromo-methyl)-cyclo-hexane	-	3322-93-8
			TBPA Na salt	-	25357-79-3
			Tetrabromo phthalic-anhydride	-	632-79-1
Metal compounds	A11	Table U:Nickel	Nickel	1.000	7440-02-0
	C05	Table V:Phthalates	Bis (2-ethylhexyl) phthalate (DEHP)	-	117-81-7
			Dibutylphthalate (DBP)	-	84-74-2
			Bis(2-methoxyethyl) phthalate (DBP)	-	117-82-8
Metal compounds	A13	Table W:Selenium/ Selenium Compounds	Selenium	1.000	7782-49-2
			Hydrogen selenide	0.975	2148909
			Sodium selenide	0.632	1313-85-5
			Selenium dioxide	0.712	2025852
			Sodium selenate	-	10112-94-4
			Dimethyl selenide	0.724	593-79-3
			Selenium oxide	-	12640-89-0
			Other selenium compounds	-	-
	B07	Table X:Polyvinyl Chloride	Polyvinyl chloride (PVC)	-	9002-86-2

Exhibit 6. Survey and Response Format (Data Format)

Output file (JGP file) Specifications

1 Line code

Basic information line 1	Line code 100
Basic information line 2	Line code 110
Basic information line 3	Line code 120
Part unit line	Line code 200
Substance groups unit line	Line code 300
Substance unit line	Line code 400
Material unit line	Line code 500
Intended use/Application unit line	Line code 600

Setting up eight lines above-mentioned lines, the line code is described at the head of line.
The relationship of the data are assigned by the order of the lines.

2 Composition of JGP file Ver.3.00 for chemical substances

- The basic information lines 1,2 and 3 should be described in one line for one file.
- Two or more parts can be existed in one line.
- Two or more substance groups can be related to one part.
- Two or more intended use/application can be related to one substance group.
- The substance group of a part is described in a substance group unit line located after a part unit line.
- The intended use/application related to one substance group is described in intended use/application line located after a substance group line.
- TAB is used to separate data in each line.

Image of JGP file

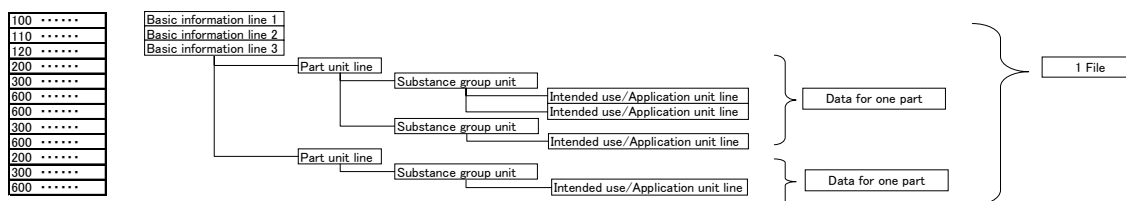

Revision History:

Sep.28.2005: (New release)
 May.16.2006: (Revised intended use classification master)
 Dec.25.2006: (Revised intended use classification master and changed number of input character restriction.)

*2 Do not use for Ver3.00 →
 Modified or added in Ver3.00 →
 Modified or added in Ver3.21 →

Basic information line 1

Data order	1	2	3	4	5	6	7	8	9	10
Content	Line code	Language flag	format version *7	Reference No.	Date of entry	Parts mass unit *2	Substance mass unit *2	Tool name	Respondent's date of data entry	Response type
Byte	3	1	5 and below	30 and below	10	1	1	40 and below	10	1
Remarks	100	0 : Japanese 1 : English	3.10		YYYY/MM/DD	1 :mg 2 :g 3 :kg 4 :t	1 :mg 2 :g 3 :kg 4 :t		YYYY/MM/DD	0 : Standard type 1 : Detailed type

*7 When the intended use application list is updated, raise the number of the first decimal place. Raise the number of the second decimal place for other change.

Basic information line 2

Data order	1	2	3	4	5	6	7	8	9	10
Content	Line code	Requester Division Name (English)	Requester Contact Name (English)	Requester Telephone No.	Requester Fax No.	Requester Email Address	Requester's management items 1	Requester's management items 2	Requester's management items 3	Respondent Company Name (English)
Byte	3	200 and below	100 and below	100 and below	100 and below	100 and below	80 and below	80 and below	80 and below	200 and below
Remarks	110									
	11	12	13	14	15	16	17	18	19	20
	Respondent Address (English)	Respondent Division Name (English)	Respondent Contact Name (English)	Respondent Telephone No.	Respondent Fax No.	Respondent Email Address	Requester's management items 4	Requester's management items 5	Requester's management items 6	Requester's Company Name (English)
	200 and below	200 and below	100 and below	100 and below	100 and below	100 and below	80 and below	80 and below	80 and below	200 and below
	21	22	23							
	Requester DUNS Number	Respondent DUNS Number	Additional information regarding survey responses (English)							
	9	9	200 and below							

Basic information line 3

Data order	1	2	3	4	5	6	7	8	9
Content	Line code	Requester Division Name (Japanese)	Requester Contact Name (Japanese)	Respondent Company Name (Japanese)	Respondent Address (Japanese)	Respondent Division Name (Japanese)	Respondent Contact Name (Japanese)	Requester's Company Name (Japanese)	Additional information regarding survey responses (Japanese)
Byte	3	200 and below	40 and below	200 and below	200 and below	200 and below	40 and below	200 and below	200 and below
Remarks	120								

Part unit line

Data order	1	2	3	4	5	6	7	8	9	10
Content	Line code	Product/subpart number of requester	Product / subpart/material name of requester	Requester's Item1	Requester's Item2	Requester's Item3	Manufacturer Name	Respondent's product/subpart's/material number	Respondent's Item1	Respondent's Item2
Byte	3	200 and below	160 and below	40 and below	40 and below	40 and below	200 and below	200 and below	200 and below	200 and below
Remarks	200									
	11	12	13	14	15	16	17	18	19	20
	Respondent's Item3	Surveying Unit	Survey Unit Mass (g/unit)	Use of ozone-depleting substances *2	List A substances contained *2	Column 7 *2	Column 8	Column 9 *2	Column 10 *2	Column 11 *2
	200 and below	20 and below	20 and below	1	1	80 and below	80 and below	80 and below	80 and below	80 and below
				0: No 1: Yes	0: No 1: Yes					
	21	22	23	24	25	26	27	28	29	30
	Column 12 *2	Data Version	Revision Date	Material Grade No.	Metal Type·JIS symbols	Coloring No.	Thickness(mm)	Color	Diameter(mm)	Respondent's product/subparts
	80 and below	40 and below	10	60 and below	60 and below	40 and below	10 and below	60 and below	10 and below	160 and below
			YYYY/MM/DD							
	31									
	Overall Content Flag									
	1									
	0 : N *3 1 : Y									

*3 Input Y, when more than one content flag is Y. Input N when all of content flags are N. However, even one blank (null) in any content flag, makes this column blank (null).

Substance group unit line

Data order	1	2	3	4	5	6	7	8	9	10
Content	Line code	Classification No.	Total sum *2	Total Content (mg)	Application area *2	Purpose of use *2	Column 13 *2	Column 14 *2	Column 15 *2	Content Flag by Threshold Level
Byte	3	3	20 and below	20 and below	80 and below	80 and below	80 and below	80 and below	80 and below	1
Remarks	300									0 : N 1 : Y
	11									
	Additional information on material composition of products *4									
	80 and below									

*4 Use this column to input data at every substance group, when use standard type.

Intended use/Application unit line

Data order	1	2	3	4	5	6	7
Content	Line code	Intended use classification code	Purpose of use/Intended use	Application area	Content (mg)	Maximum content rate (ppm) *5	Additional information on material composition of products *6
Byte	3	12 and below	80 and below	80 and below	20 and below	20 and below	80 and below
Remarks	600						

*5 Maximum content rate (ppm) for Standard type. Content rate (ppm) for Detailed type.

*6 Use this column to input data at every intended use application, when use Detailed type.

Exhibit 7. JGPSSI Format 1 (Standard Type) for Handwritten Response

Requester & Respondent Information

Requester Information	Reference Number	
	Date of Data Entry	
	Company Name	
	DUNS Number	
	Division Name	
	Contact Name	
	Telephone Number	
	Fax Number	
	Email Address	

Respondent Information	Respondent's date of data	
	Company Name	
	DUNS Number	
	Division Name	
	Address	
	Contact Name	
	Telephone Number	
	Fax Number	
	Email Address	
	Additional information regarding survey responses	

Parts Information

Parts Number	Parts Name	Manufacturer Name	Type	Data Version	Revision Date	Surveying Unit	Survey Unit Mass	Overall Content Flag
							(g)	

Contained substance information - Content Flag / Total Content *1 by Threshold Level

Level	Classification No.	Substance Groups	*1 Content		Total Content (mg)
Level A	A05	Cadmium and Cadmium Compounds	Y	N	
	A07	Hexavalent Chromium Compounds	Y	N	
	A09	Lead and Lead Compounds	Y	N	
	A10	Mercury and Mercury Compounds	Y	N	
	A17	Tributyl Tin Oxide (TBTO)	Y	N	
	A18	Tributyl Tins & Triphenyl Tins	Y	N	
	B02	Polybrominated Biphenyls (PBBs)	Y	N	
	B03	Polybrominated Diphenyl ethers (PBDEs)	Y	N	
	B05	Polychlorinated Biphenyls (PCBs)	Y	N	
	B06	Polychloronaphthalenes (Cl ³)	Y	N	
	B09	Short Chain Chlorinated Paraffins	Y	N	
	C01	Asbestos	Y	N	
	C02	Azo Colorants	Y	N	
	C04	Ozone Depleting Substances	Y	N	
	C06	Radioactive Substances	Y	N	

Level	Classification No.	Substance Groups	*1 Content Flag		Total Content (mg)
Level B	A01	Antimony and Antimony Compounds	Y	N	
	A02	Arsenic and Arsenic Compounds	Y	N	
	A03	Beryllium and Beryllium Compounds	Y	N	
	A04	Bismuth and Bismuth Compounds	Y	N	
	A11	Nickel	Y	N	
	A13	Selenium and Selenium Compounds	Y	N	
	B07	Vinyl Chloride Polymer (PVC)	Y	N	
	B08	Brominated Flame Retardants	Y	N	
C05	Phthalates	Y	N		

Please follow instructions in the Survey and Response Manual to fill each columns.

Contained substances - Detailed information

Classification No.	Intended Use Classification Code	Purpose of Use/Intended Use	Application area	Maximum Content Rate (ppm)	Additional information on material composition of products
Level A (Continues to next page)	A05				
	A07				
	A09				
	A10				
	A17				
	A18				
	B02				
	B03				

Exhibit 7. (cont'd) **JGPSSI Format 1 (Standard Type) for Handwritten Response**

Classification No.	Intended Use Classification Code	Purpose of Use/Intended Use	Application area	Maximum Content Rate (ppm)	Additional information on material composition of products
Level A (continued)	B05				
	B06				
	B09				
	C01				
	C02				
	C04				
	C06				
Level B	A01				
	A02				
	A03				
	A04				
	A11				
	A13				
	B07				
	B08				
	C05				

