

**VICOR CONFIDENTIAL**

THIS DOCUMENT AND THE DATA DISCLOSED HEREIN OR HEREWITH IS NOT TO BE REPRODUCED, USED, OR DISCLOSED IN WHOLE OR IN PART TO ANYONE WITHOUT PERMISSION OF VICOR CORP.

REV.	DESCRIPTION	DATE	APVD
1	RELEASED PER E053460	LEK 12/08/05	RT
2	REVISED PER E063752	PEI 03/29/06	RT
3	REVISED PER E063923	GCK 5/25/06	RT

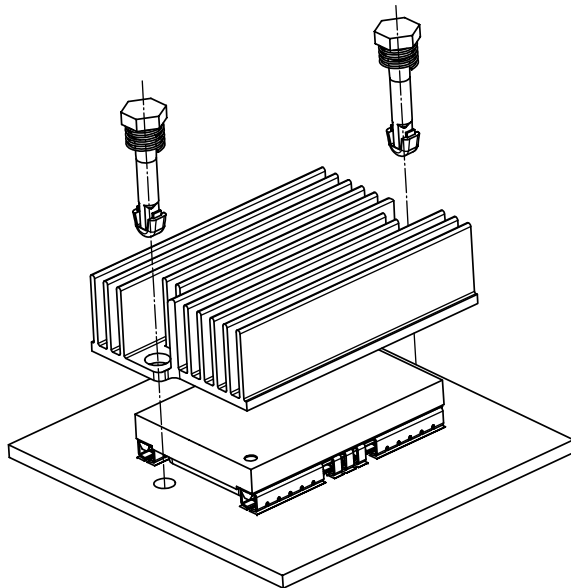

**X-FLOW (XF)**  
(HEAT SINK ONLY SHOWN)

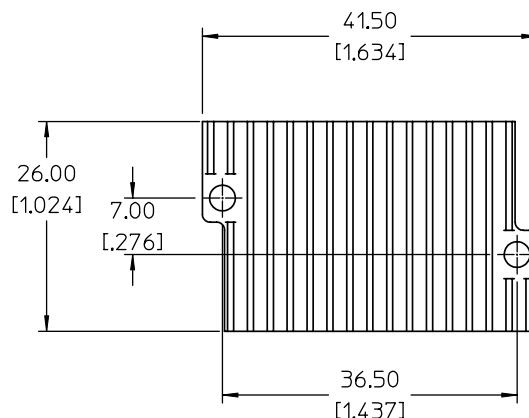

**LONGITUDINAL FLOW (LF)**  
(HEAT SINK ONLY SHOWN)

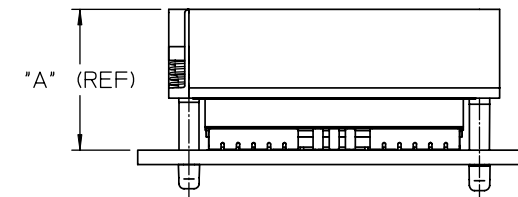
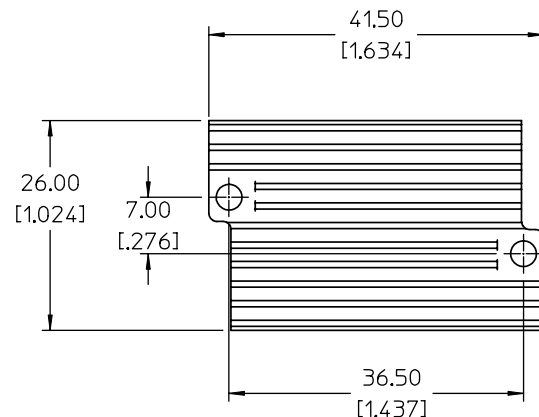

**J-LEAD MOUNT**

**PUSH-PIN FOR VI-CHIP HEATSINK CHART**

PUSH-PINS W/ SPRINGS (100/BAG)	COLOR	PCB THK NOMINAL RANGE	PCB THK MINIMUM	PCB THK MAXIMUM
32434	WHITE	1.30 TO 1.75 MM [.051" TO [.069"]	1.168 MM [.046"]	1.956 MM [.077"]
32435	BLACK	1.78 TO 2.64 MM [.070" TO [.104"]	1.600 MM [.063"]	2.921 MM [.115"]
32436	BLUE	2.67 TO 3.35 MM [.105" TO [.132"]	2.388 MM [.094"]	3.706 MM [.146"]
32437	GRAY	3.38 TO 3.96 MM [.133" TO [.156"]	3.048 MM [.120"]	4.369 MM [.172"]

**HEATSINK CHART**

HEAT SINK HEIGHT	XF P/N	XF "A" DIM	LF P/N	LF "A" DIM
11MM	32438	17.83/[.702]	32440	17.83/[.702]
6.3MM	32439	13.13/[.517]	32441	13.13/[.517]

**NOTES:**

- FOR PCB LAYOUT SEE VICOR APPLICATION DRAWING 29806 FOR J-LEAD MOUNT V\**I* CHIP.
- PUSH-PIN INSTALLATION:  
TO MINIMIZE STRESS IN THE VIC-TO-PCB SOLDER CONNECTIONS, PRESS THE PUSH-PINS THROUGH THE HOLES ON THE HEATSINK PRIOR TO INSTALLATION ON THE VIC.

THEN PLACE THE HEATSINK ASSEMBLY ON THE SURFACE OF THE VIC, AND PRESS THE PUSH-PINS THROUGH THE HOLES ON THE PCB. IT IS CRITICAL TO SUPPORT THE UNDERSIDE OF THE PCB AT EACH HOLE LOCATION TO AVOID FLEXING THE PCB DURING PUSH -PIN INSTALLATION.

CARE SHOULD ALSO BE TAKEN TO AVOID FULLY COMPRESSING THE PUSH-PIN SPRINGS DURING INSTALLATION AS THIS WOULD EXPOSE THE VIC TO FORCES GREATER THAN THE RECOMMENDED LIMIT OF 3LBF (13.3N) PER PUSH-PIN.

- DIMENSIONS ARE IN MM  
[INCH]

DRAWN BY <b>D.CYNAR</b>		DATE <b>7/27/05</b>			
UNLESS OTHERWISE SPECIFIED DIMENSIONS ARE MM (INCH) TOLERANCES ARE: DECIMALS ANGLES .XX* ±0.25 (.01) ±1° .XXX* 0.127 (.005)					
THIRD ANGLE PROJECTION		SIZE C	FSCM NO. 67131	DWG NO. 30553	REV 3
DO NOT SCALE DRAWING		SCALE 2:1	SHEET 1 OF 1		