

Power Supply Design Considerations For High di/dt Loads

June 11th, 2002

Bob Pauplis, Presenter

Senior Applications Engineer

Vicor Corporation



Overview of Presentation

- Dynamic loads: definition and examples
- Components of the transient response
- Contributing factors to the transient response
- Designing a power system to minimize transient excursion
- Designing an application to minimize parasitics
- Selecting a power converter with an optimal dynamic response
- Questions and Answers

Power Conversion Overview

Generic DC-DC Converter

Power Conversion Module

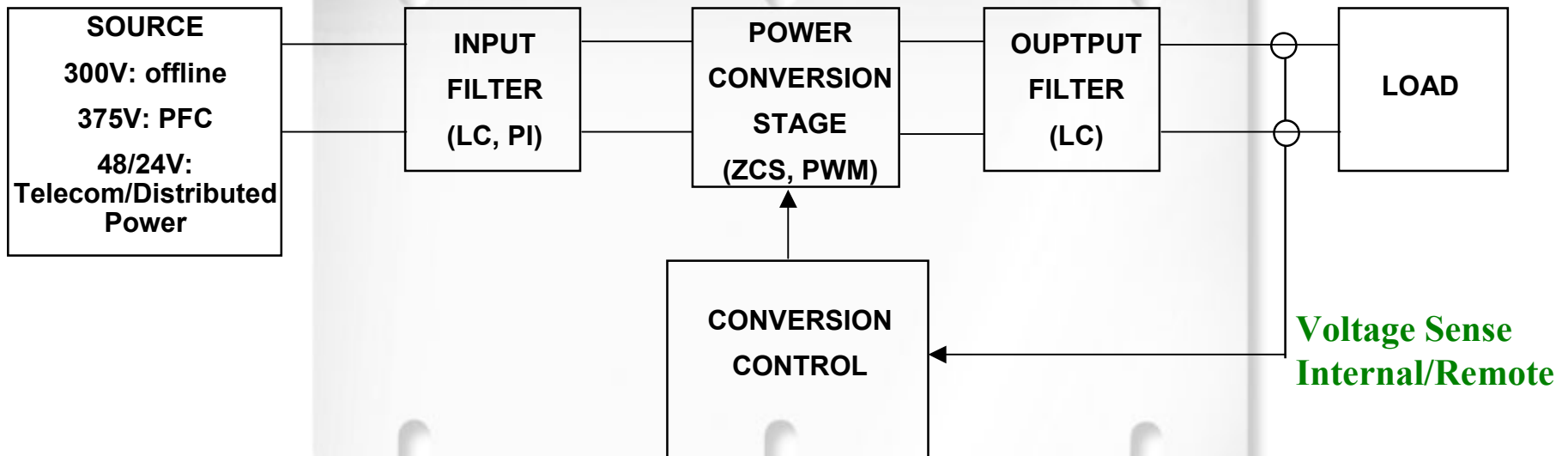

Dynamic Load: What Is It?

Any device connected to the output of a power source that draws varying current is a dynamic load.

Types of Loads

- Resistive (switched heaters, lighting)
- Complex (motors, power amplifiers, electronic circuitry)
- Negative Impedance (DC-DC power supplies)

Load Characteristics

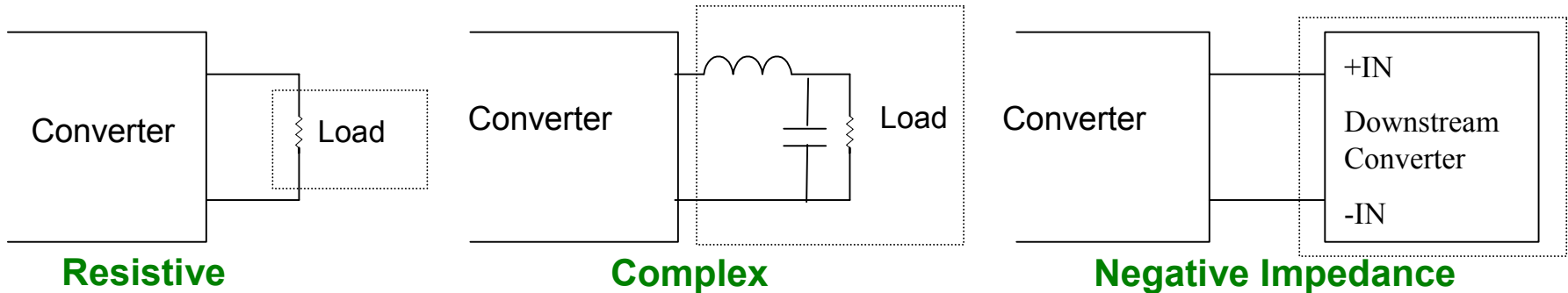

- **Combinations of different load types can yield an infinite range of load characteristics**

Load Type	Affects control loop response	Affects transient response
Resistive	No	No
Complex	Yes	Yes
Negative Impedance	Possibly	Possibly

Transient Response: What Is It?

The output voltage excursion in response to a change in load is defined as the converter's load transient response.

- Differs depending on whether the load is increasing or decreasing and on the rate of change
- May not be detectable for certain dynamic loads
- Basic form and attributes independent of converter topology

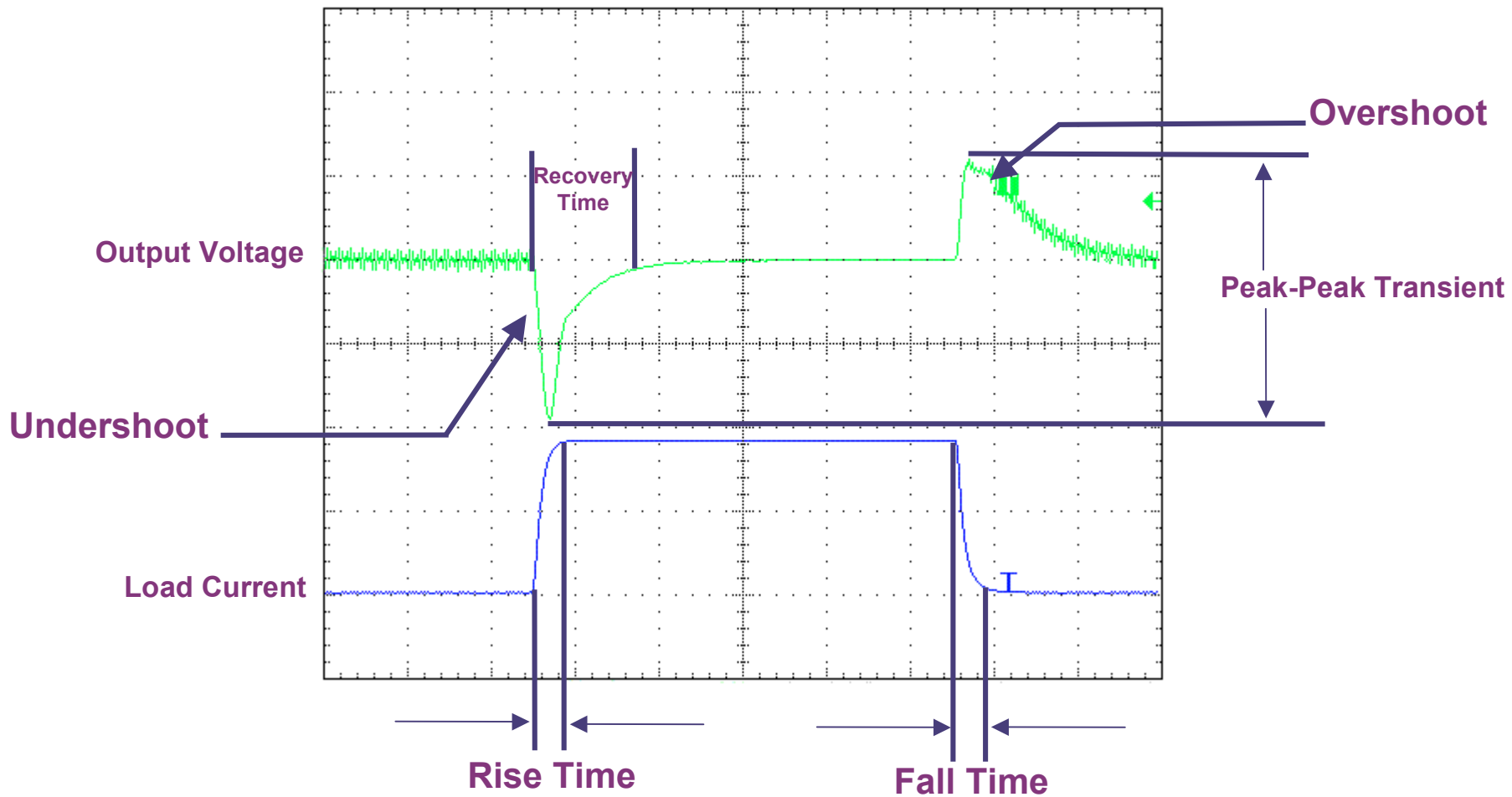

Transient: Definition of Terms

- **Overshoot:** Voltage excursion in response to a negative going change in output current
- **Undershoot:** Voltage excursion in response to a positive going change in output current
- **Peak-peak transient:** Total voltage excursion in response to a change in output current followed by a return to the original current level
- **Recovery time:** Time required for overshoot or undershoot to fall within 1% of the steady state value
- **Rise/Fall time:** Time required for the load to transition between two values of current
- **Slew rate (di/dt):** Change in output current divided by rise/fall time

What Affects Transient Response?

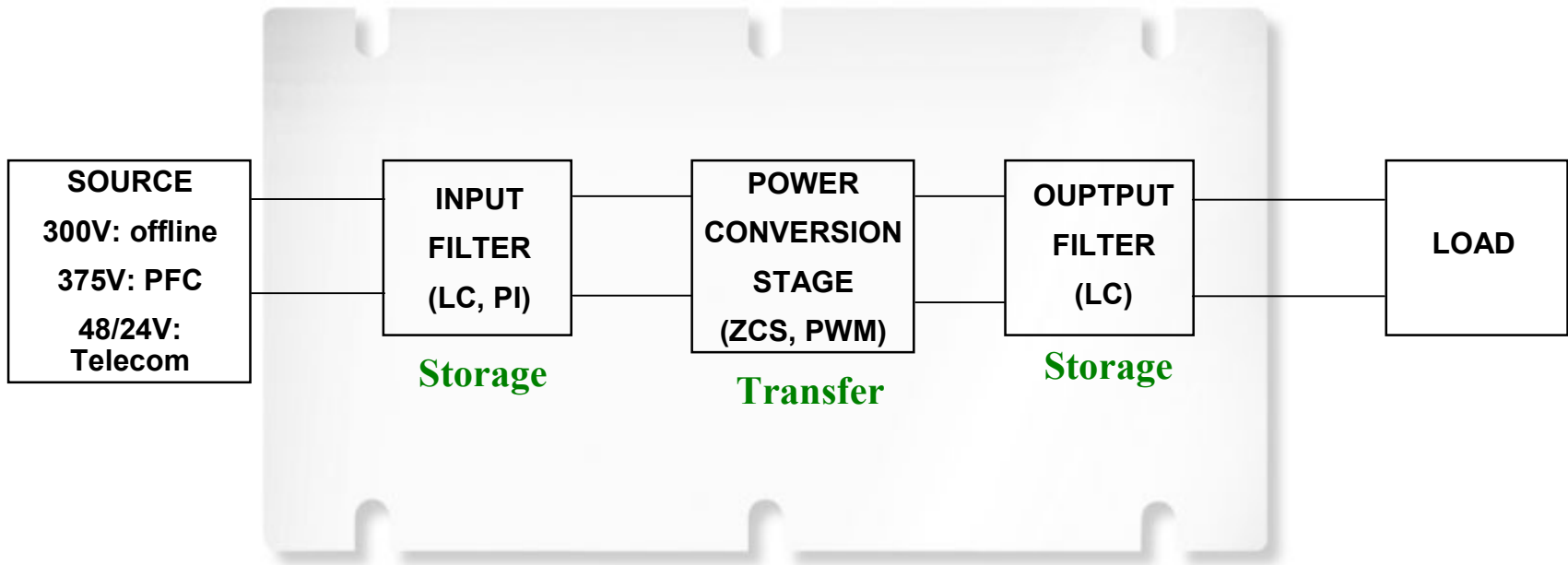

- Energy flows from input to output of a converter, with each stage of the converter either storing or transferring energy
- The magnitude of the transient response is primarily affected by how quickly this energy flow can be increased or decreased

In Other Words...

It's a Bucket Brigade

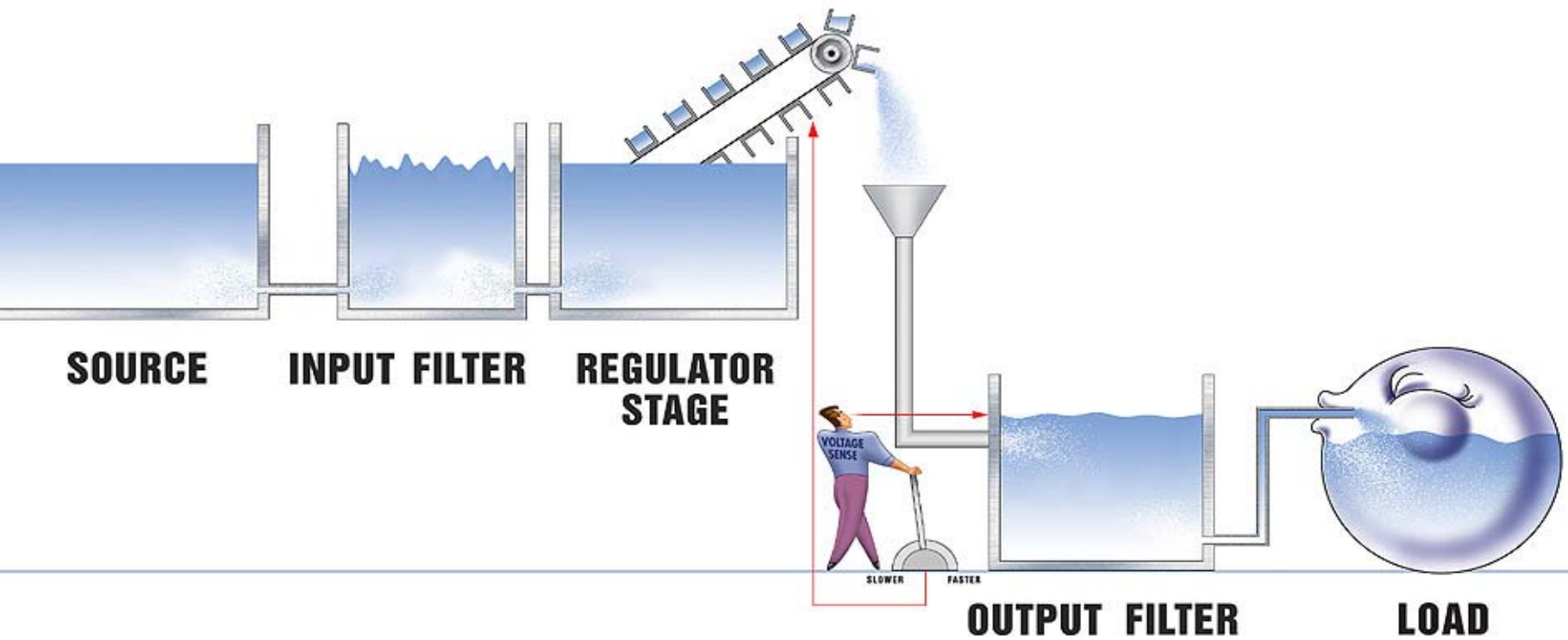

Why Is a Fast Response Important?

■ Protection of applications

- Voltage stresses from overshoots
- Functionality of application
- Disruption of sensitive equipment
- Introduction of noise

■ Protection of power system

- Minimize stress on output stage
- Minimize stress on input stage

Why Is a Fast Response Important? (Continued)

- **IC's and computing applications:** minimize voltage stresses, errors
- **Telecom and communications:** minimize noise
- **Test and measurement:** minimize impact on sensitive equipment
- **Military:** performance and ruggedness of application
- **Medical:** Performance and noise management

It's All About The Power...

Instantaneous Power: $P_{inst}(t) = v(t) \cdot i(t)$

Average Power:
$$P_{avg} = \frac{V_{out}}{T} \int_0^T i(t) dt$$

- Transient response affects instantaneous power
- A power converter is capable of delivering a constant average power per unit time (T) corresponding to the converter's bandwidth

It's All About The Power...

Perfect Converter

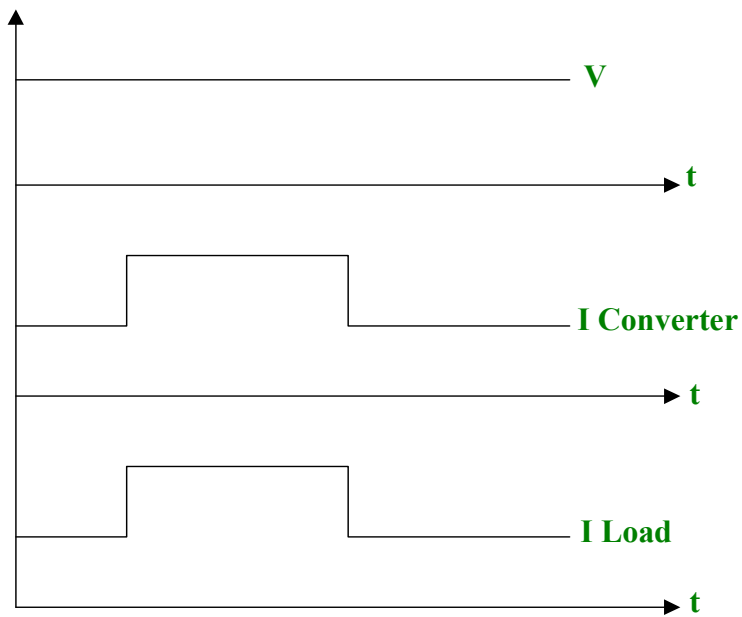

Real Converter

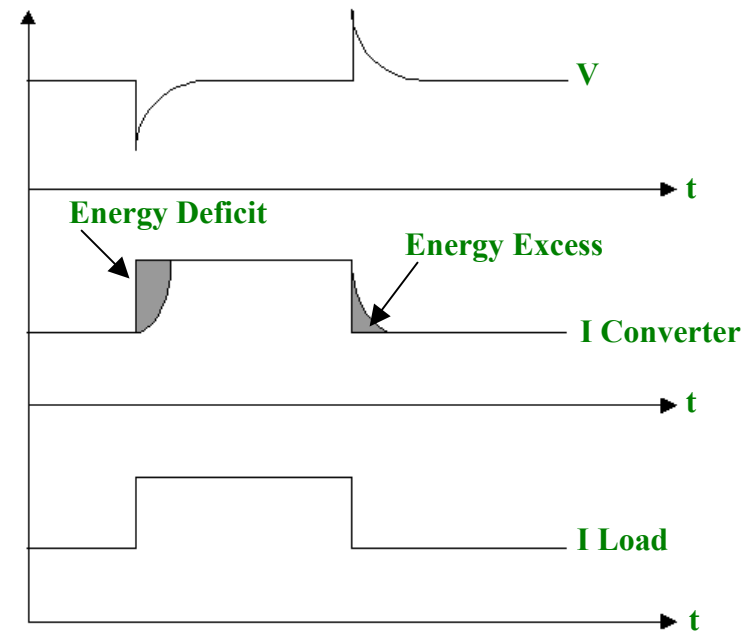

Dissecting The Transient Response

Q: What portion of the power converter impacts the voltage excursion?

A: All stages of power conversions affect the overall transient response.

Q: What portion of the power converter most often takes the blame for a poor transient response?

Dissecting The Transient Response

A: The last one in line...the output filter.

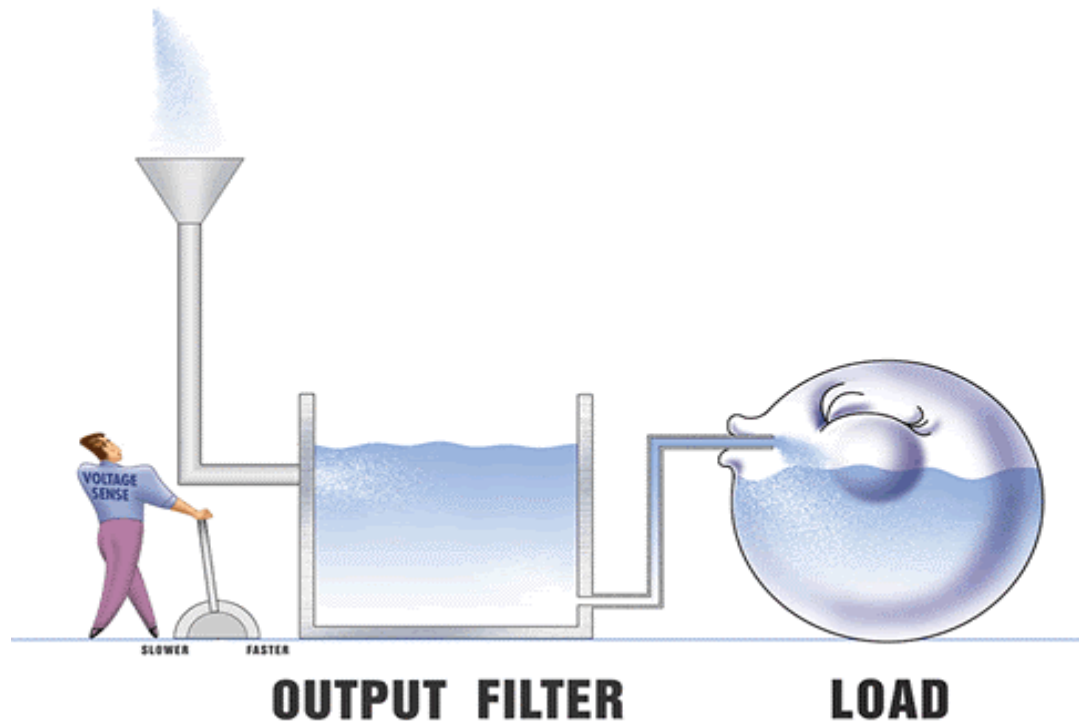

How does the output filter actually contribute?

Contributing Factors: Output Filter

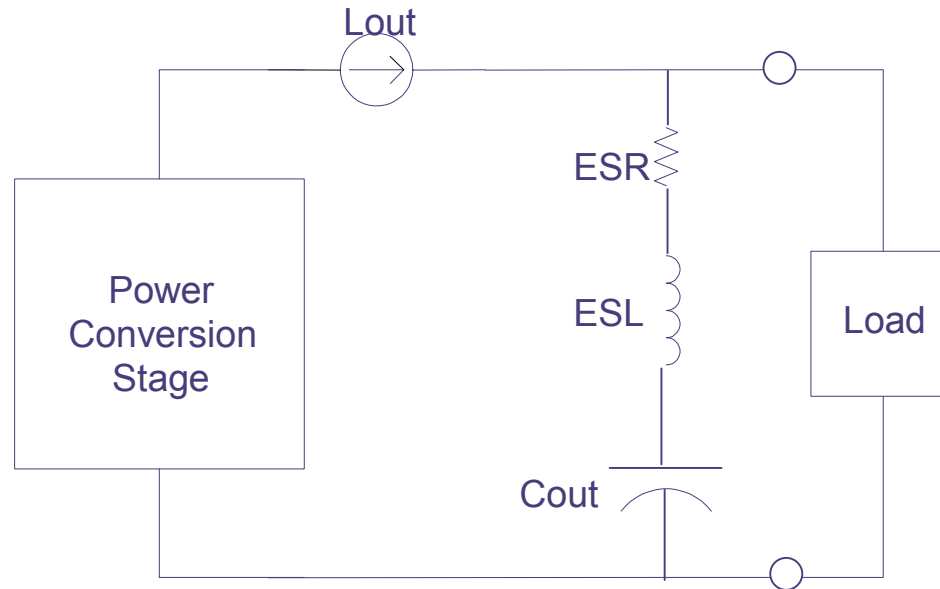

- Output inductor functions as a current source providing all load current (prior to load step)
- Load voltage is equal to output voltage set by power conversion stage
- Inductor current cannot change instantaneously

Contributing Factors: Output Filter

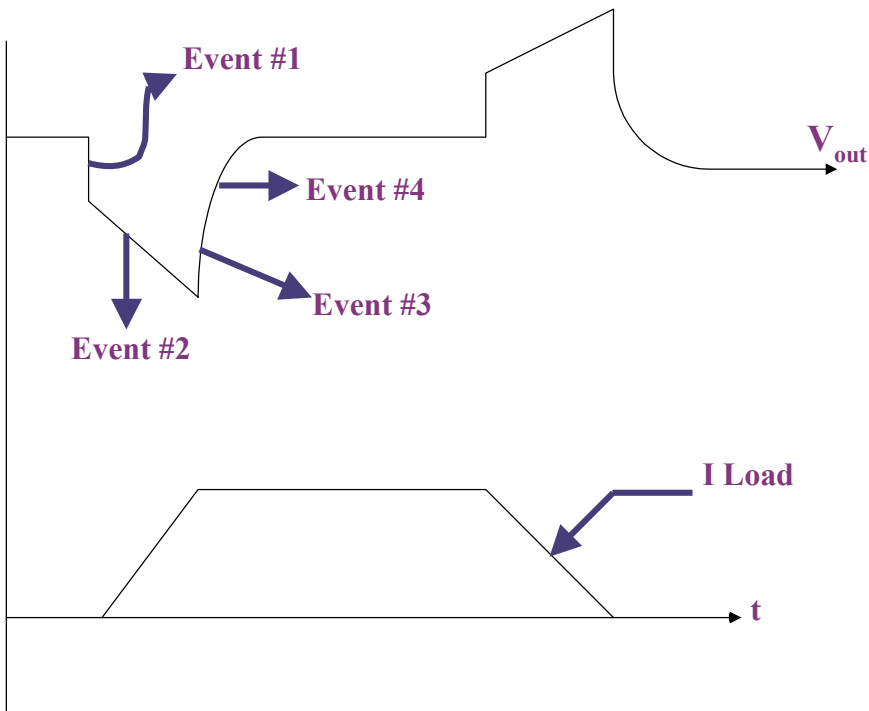

Note: Time scale and parasitic effects are amplified to illustrate contribution. Typically events 1-3 occur well outside of the bandwidth of the converter.

Event #1: ESL component.

Event #2: ESR component.

Event #3: ESL component diminished.

Event #4: CV^2 and loop recovery components.

Contributing Factors: Output C

Event #1:

Output L continues to supply original load current, as the control loop has not yet started to respond load change. All new load current comes from the output capacitor. As the ESL component is inductive, a voltage develops as shown. The magnitude of this voltage is given by:

$$V_{ESL}(t) = ESL \cdot \frac{di_{load}}{dt}$$

This voltage is proportional to the change in load current.



Contributing Factors: Output C

Event #2:

As the load current increases a voltage develops in proportion to the ESR of the output capacitance. This voltage is expressed as:

$$V_{ESR}(t) = ESR \cdot i_{load}(t)$$

and is proportional to the magnitude of the load current.

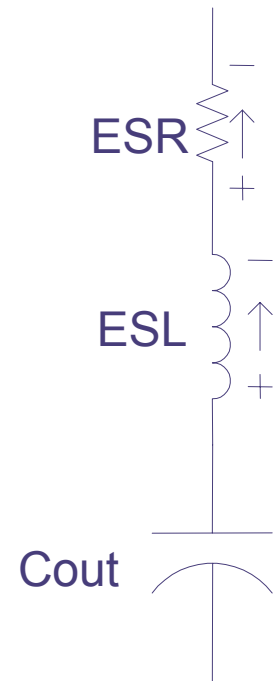

Contributing Factors: Output C

Event #3

Once the rate of change in load current (di/dt) goes to zero, the ESL contribution disappears, as the ESL contribution is only present during a changing current.



Contributing Factors: Output C

Event #4

The load current is now constant. The current through the output inductor is now increasing as the control loop is responding to the drop in output voltage.

As the power conversion rate increases, the current requirement from the output capacitor decreases, the ESR component diminishes. However, as current leaves the capacitor the voltage across the capacitor decreases. These can be expressed as the following:

$$V_{ESR}(t) = (I_{load} - i_{conv}(t)) \cdot ESR$$

$$\Delta V_{Cout}(t) = \frac{I_{load} \cdot t}{C_{out}} - \frac{1}{C_{out}} \int i_{conv}(t) dt$$



Output C: Putting It All Together

For a load step sufficiently outside of the converter's bandwidth, the output voltage can be expressed as the following:

Initial dynamic loading:
$$V_{out}(t) = V_{outinit} - ESL \cdot \frac{di_{load}}{dt} - ESR \cdot i_{load}(t)$$

Recovery:
$$V_{out}(t) = V_{outinit} - \frac{I_{load} \cdot t}{C_{out}} + \frac{1}{C_{out}} \int i_{conv}(t) dt$$

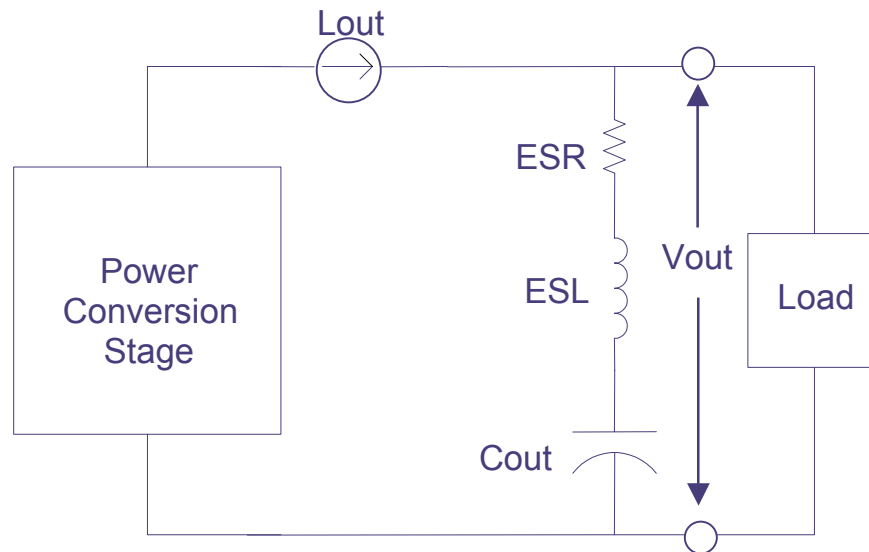

Output L: Contributing Factors

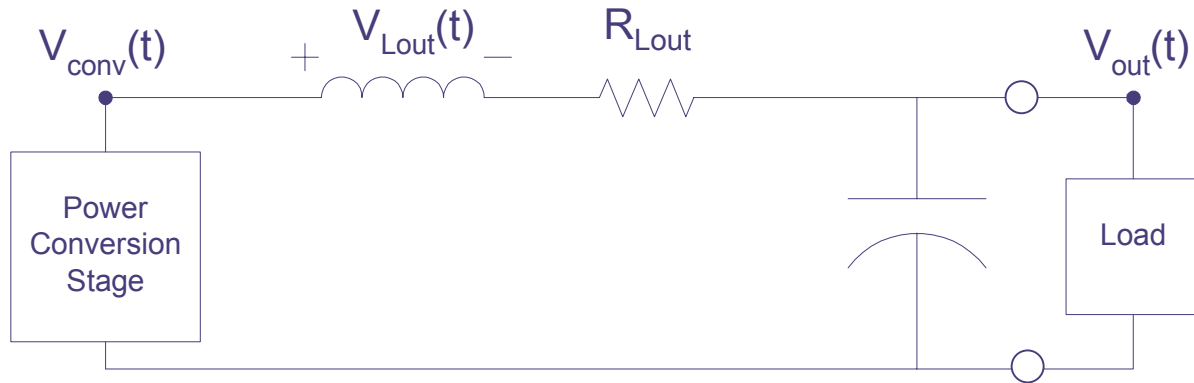

At any time, the voltage across the inductor is related to the current flowing through it is given by:

$$V_{Lout}(t) = L \cdot \frac{di_{Lout}}{dt}$$

Assuming R_{Lout} is negligible:

$$V_{Lout}(t) = V_{Conv}(t) - V_{Out}(t)$$

Output L: Contributing Factors

For any given converter, $V_{out}(t)$, is fixed. During a power conversion cycle, $V_{conv}(t)$ varies between close to 0 Volts and some maximum value. Neglecting incidental converter losses, this maximum value is defined as:

$$V_{Cmax} = V_{in} \cdot N$$

The above is for a typical PWM topology where V_{in} is the source voltage and N is the transformer turns ratio.

Output L: Contributing Factors

For a ZCS/ZVS topology:

$$V_{Cmax} = \frac{2 \cdot V_{in} \cdot M}{L_1}$$

This value is variable during the on time of the main (forward) switch. M represents a magnetic coupling term and L_1 represents the primary inductance of the main transformer.

Again, the higher $V_{conv}(t)$, the faster the output current will increase.

Contributing Factors: Output L

Another factor in determining rise rate of current through the output inductor is the inductance value. Consider the following equation again:

$$V_{Lout}(t) = L \cdot \frac{di_{Lout}}{dt}$$

For a fixed $V_{Lout}(t)$, a smaller value of L will yield a higher di/dt .

The inductance of the output L cannot, however, be arbitrarily reduced to increase output current slew rate.

- Since the output L in series with the output C performs a filtering function, a decrease in L will yield an increase in output ripple voltage, unless there is a resultant increase in operating frequency
- The output L appears in the control feedback loop for the power converter and any change affects the response of the loop

Converter-to-Load Parasitics

Recall the previous diagram:

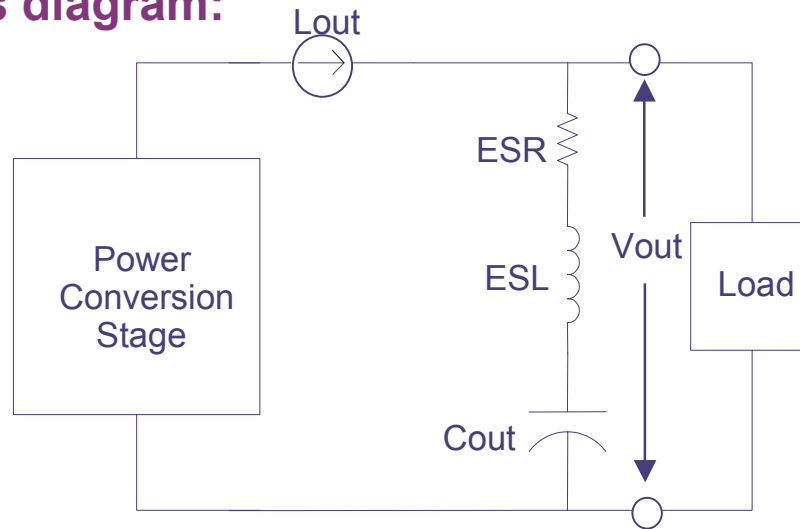

...And the previous expression for V_{out} :

$$V_{out}(t) = V_{outinit} - \frac{I_{load} \cdot t}{C_{out}} + \frac{1}{C_{out}} \int i_{conv}(t) dt$$

The above assumes a perfect connection between load and converter. Very rarely is this the case. A more realistic model would be the following...

Converter-to-Load Parasitics

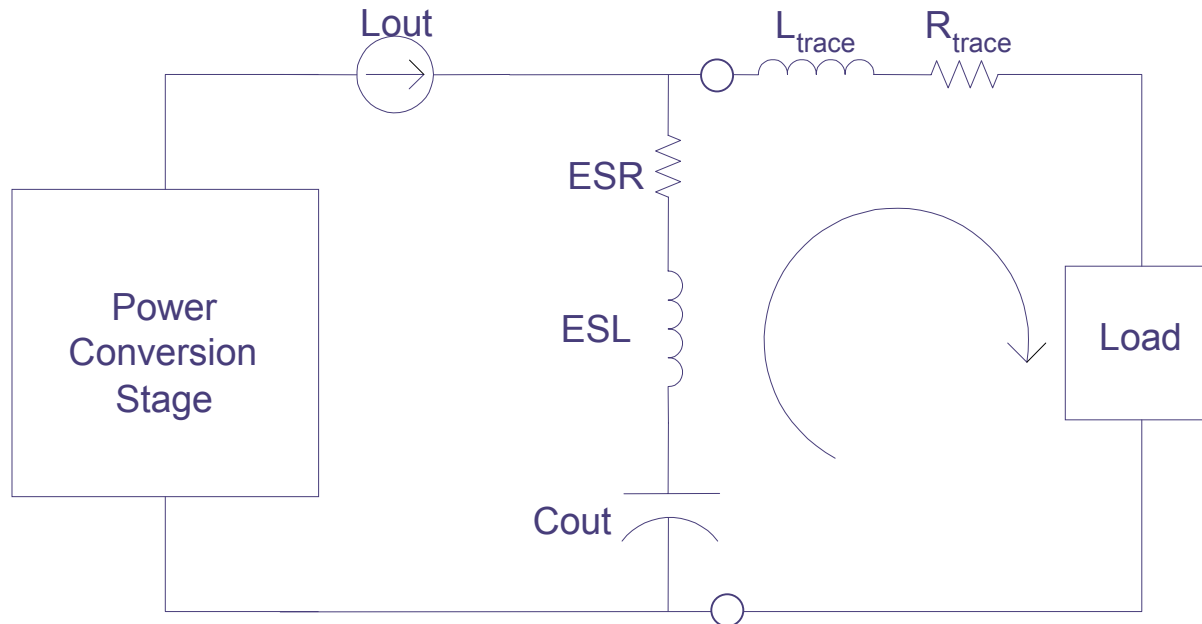

This is still only a first order model. Depending on the application and the magnitude of the di/dt , additional parasitics may come into play and affect the response.

Using KVL, new equations can be written that take into account load parasitics.

Converter-to-Load Parasitics (2)

Initial dynamic loading:

$$V_{Load}(t) = V_{outinit} - ESL \cdot \frac{di_{load}}{dt} - ESR \cdot i_{load}(t) - L_{trace} \cdot \frac{di_{load}}{dt} - R_{trace} \cdot i_{load}(t)$$

Recovery:

$$V_{Load}(t) = V_{outinit} - R_{trace} \cdot I_{load} - \frac{I_{load} \cdot t}{C_{out}} + \frac{1}{C_{out}} \int i_{conv}(t) dt$$

- Remote sensing at the load will compensate for R_{trace} during constant loading but not during dynamic loading if outside of the converter's bandwidth.
- Converter-Load parasitics can be worse than output filter parasitics

Converter-to-Load Parasitics (3)

What Are Some Of The Causes For These Parasitics?

Trace R

- Connections between converter and PCB (solder, socket, connector)
- PCB trace length (copper width and thickness)
- Wires or harnesses connecting converter to load

Trace L

- Loop area between + and - output tracks from converter to load
- Routing of PCB tracks through board
- Parasitic magnetic fields
- Effective loop area of wires or harnesses between converter and load



Concerns with Parasitics

- Parasitic inductance affects the feedback control loop of the converter (if voltage is sensed at the load). Since is parasitic, it is inherently difficult to quantify and could produce erratic results and converter instability.
- Parasitic resistance, for a high current, low voltage application could increase voltage deviation significantly as well as affect power output. For example, 70 Amps through 20 milliohms will have a drop of 1.4V.

Concerns With Parasitics

- Unpredictable elements of parasitic inductance on the output stage of a power converter create the possibility of resonance with load capacitance
- The Q of this parasitic L is defined as:

$$Q \equiv \frac{\omega \cdot L_{trace}}{R_{trace}}$$

Assuming a small parasitic resistance, any resonance would result in high amplitude noise. This would be a concern both for the stability of the converter and the end application.

Power Conversion Control Contributions

Bandwidth and AC gain are the primary factors in the determination of power conversion response.

Bandwidth

- Defines the maximum frequency at which the control loop has gain
- Typically below the converter's switching frequency to prevent stability issues
- Determines the maximum slew rate to which a control loop can respond

AC Gain

- Primarily determines the speed at which the control loop can respond to a perturbation occurring at a specific frequency
- Uniform gain across the bandwidth of the control loop is beneficial for transient response (mid-band gain)
- Gain should rolloff with a constant slope approaching the upper end of the converter's bandwidth (crossover frequency)

Control Loop Responses

Overdamped

- Indicative of a stable power converter
- Identified by a long settling time with absence of ringing

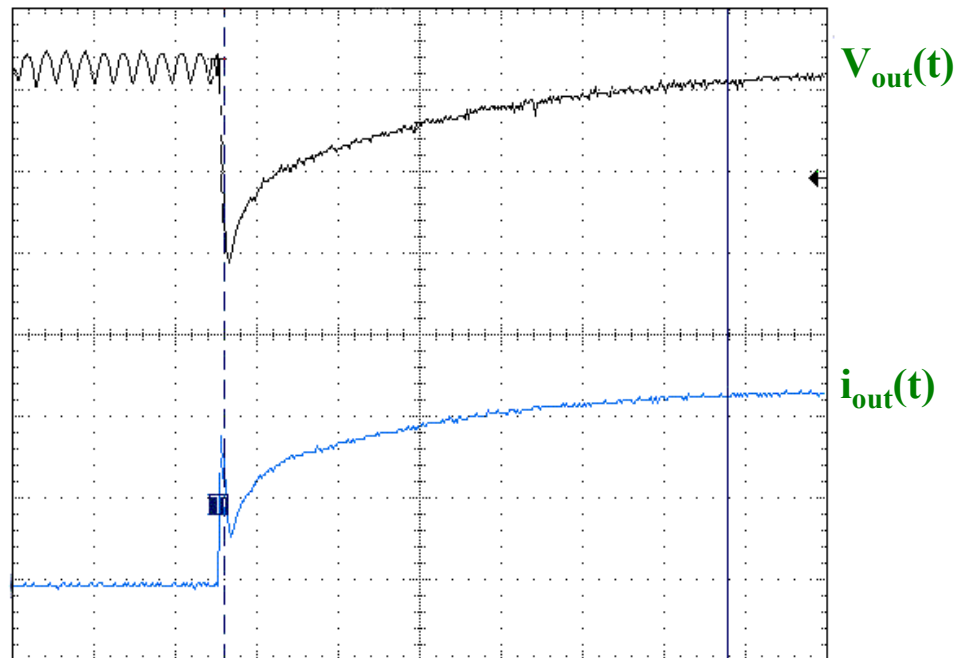

Control Loop Responses (2)

Underdamped Response

- Indicative of a gain/phase margin problem
- Represents an unstable response
- Control loop not optimized for the load

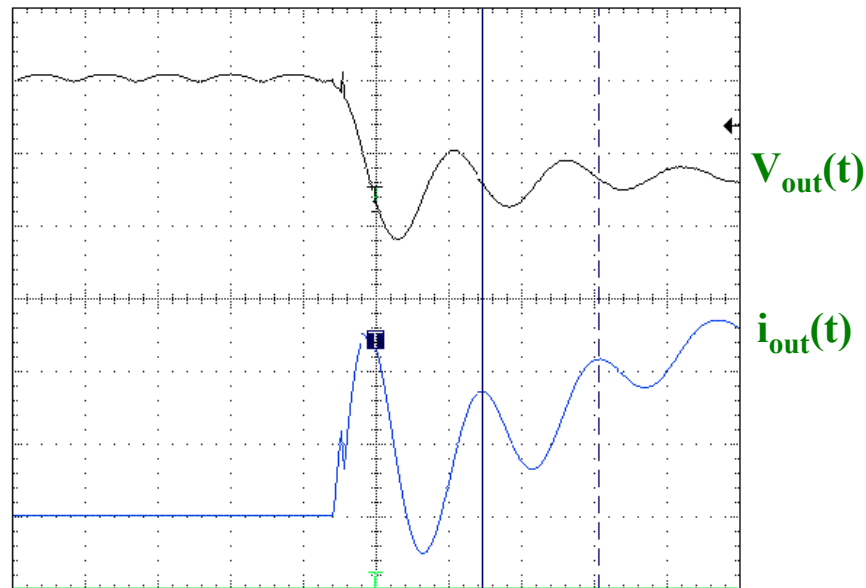

Control Loop Responses (3)

Overcorrection

- After initially recovering steady state value, voltage briefly continues further before settling
- Causes are similar to underdamped response
- Marginal stability with fast recovery time

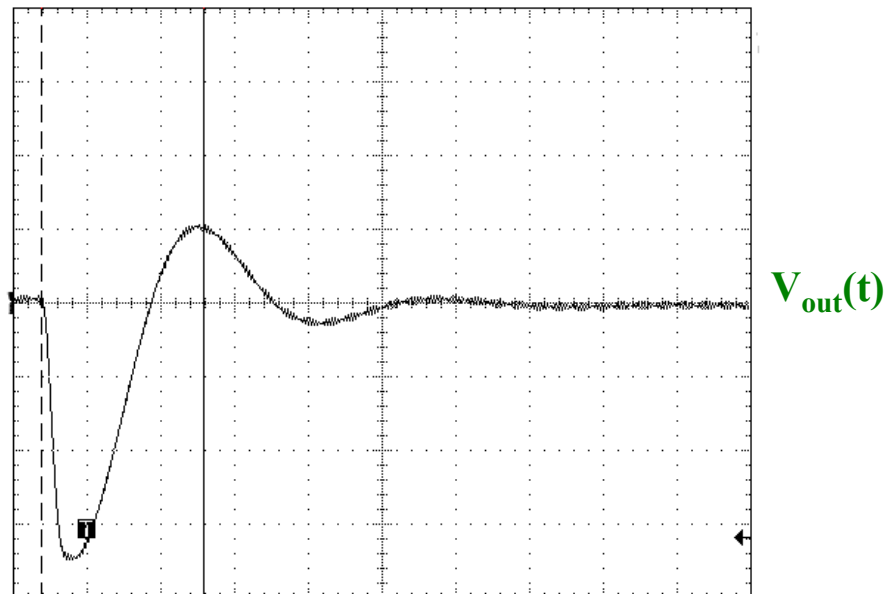



Source Impedance Contributions

- High source impedance lowers ability to rapidly supply power
- Control loop must compensate for changes in the source voltage while responding to varying load power requirements
- Control loop has finite response time
- Lower energy per conversion pulse



Optimizing The Transient Response

Power System Design

- Point-of-load capacitance
- Active transient attenuation
- Point-of-load conversion
- Single filter point-of-load capacitance

Power Converter Design Considerations

- Output filter design

Layout Considerations

- Minimizing trace inductance
- Minimizing trace resistance

Point-of-Load Capacitance

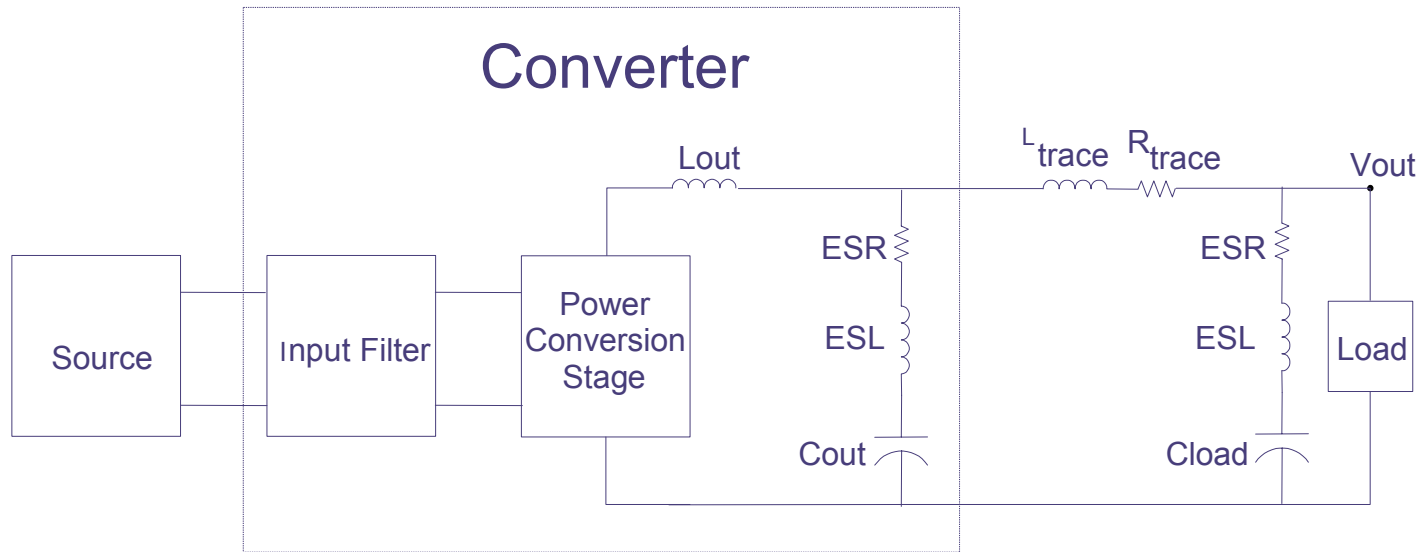

Advantages:

- Easy way to adapt standard converter for specific application
- Different capacitance can be used to adapt the same converter to a variety of loads

Point-of-Load Capacitance (2)

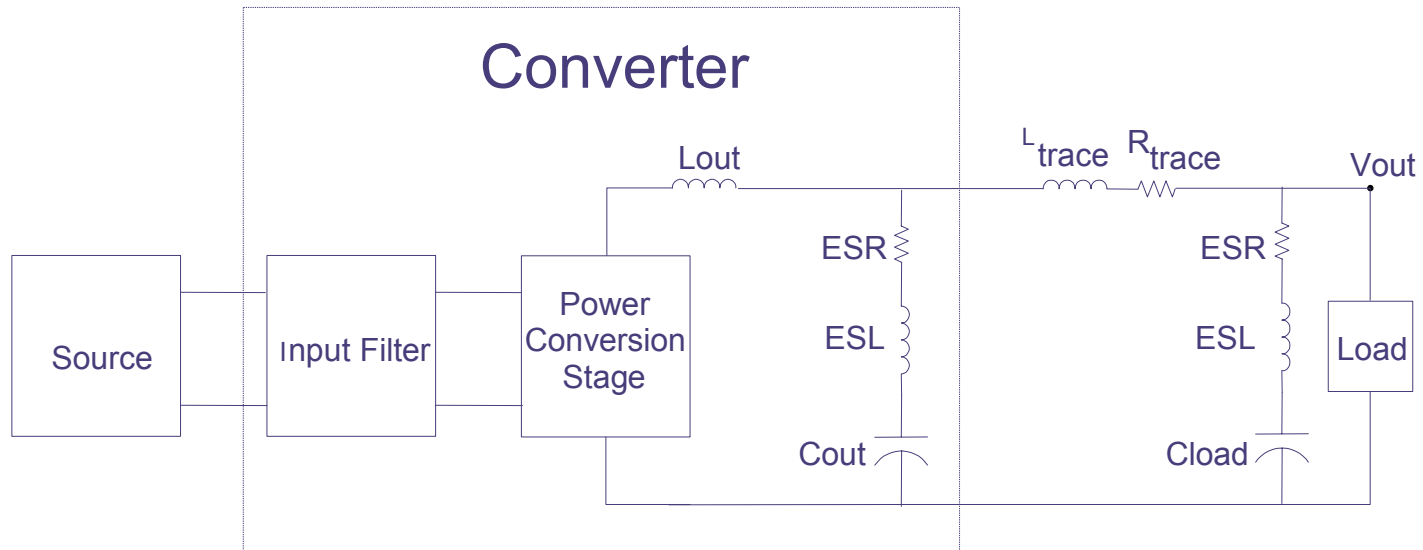

Disadvantages:

- Complex output filter (formed by load capacitance and parasitics) difficult to compensate control loop
- The shape and magnitude of transient response is modified
- Doesn't solve transient related issues with ESR and ESL of the capacitor, usually necessitating more than one capacitor and capacitor type, with associated cost and reliability concerns

Active Transient Attenuation

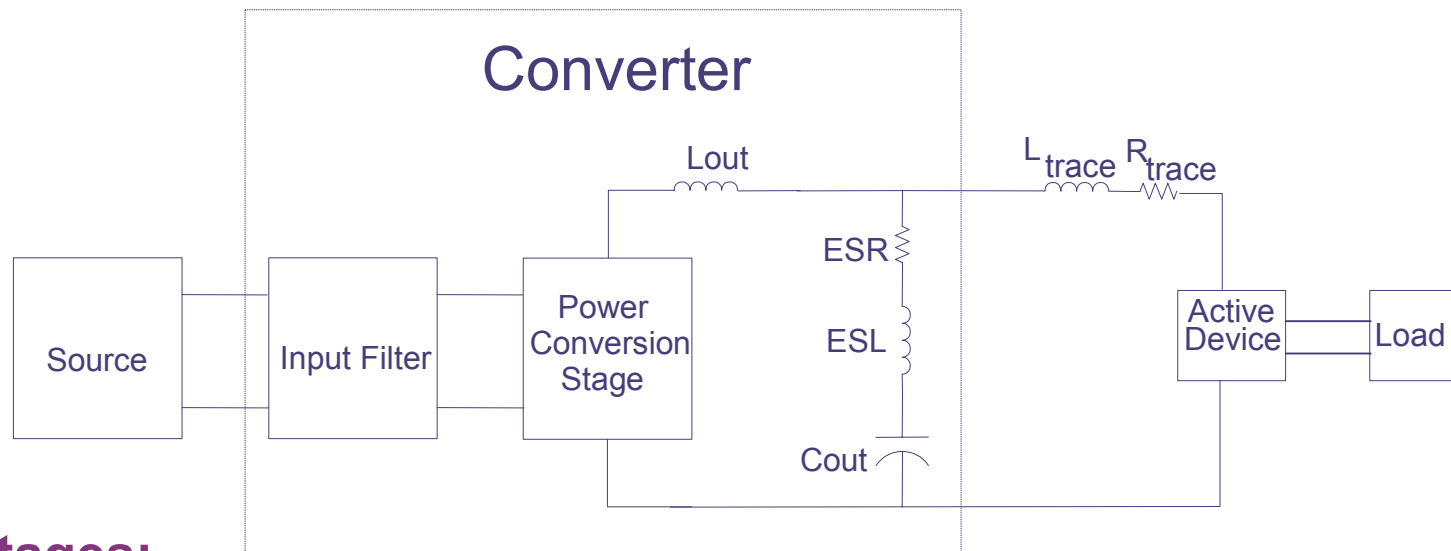

Advantages:

- Combination low pass filter and active series pass element provides transient attenuation
- Since the attenuation involves a low pass filter, there is an element of energy storage somewhat mitigating the effects of parasitics
- Allows for standardization of the power converter

Active Transient Attenuation (2)

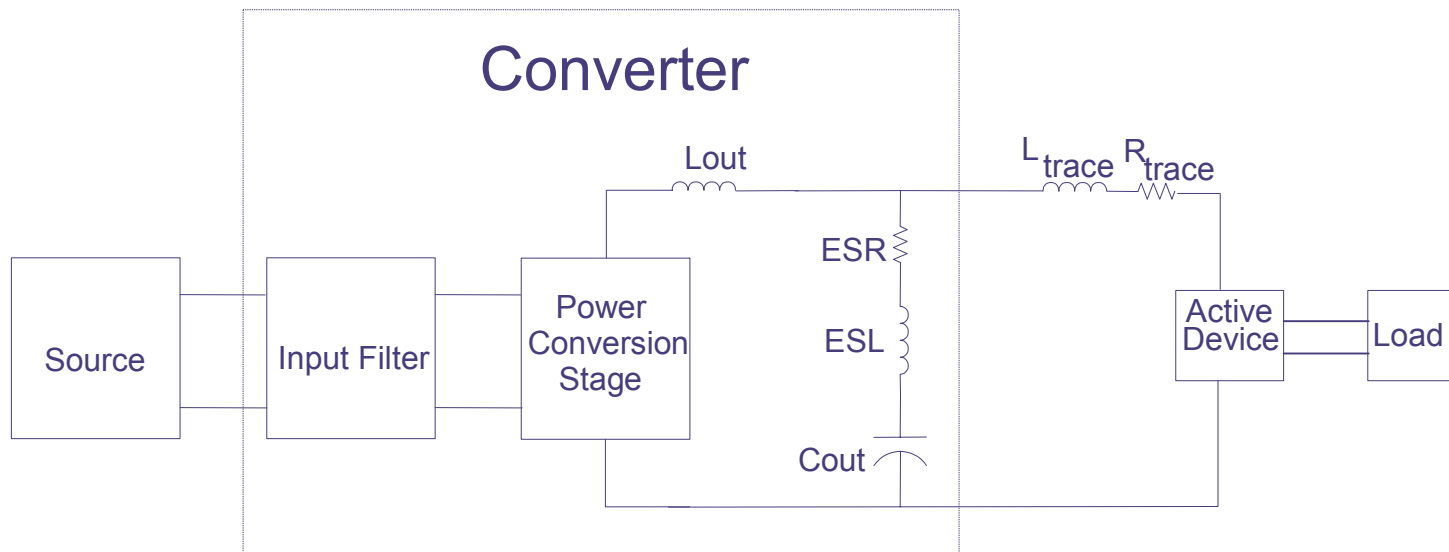

Disadvantages:

- Reduces system efficiency
- Does not eliminate all transient responses
- Adds additional components and complexity to the system

Point-of-Load Conversion

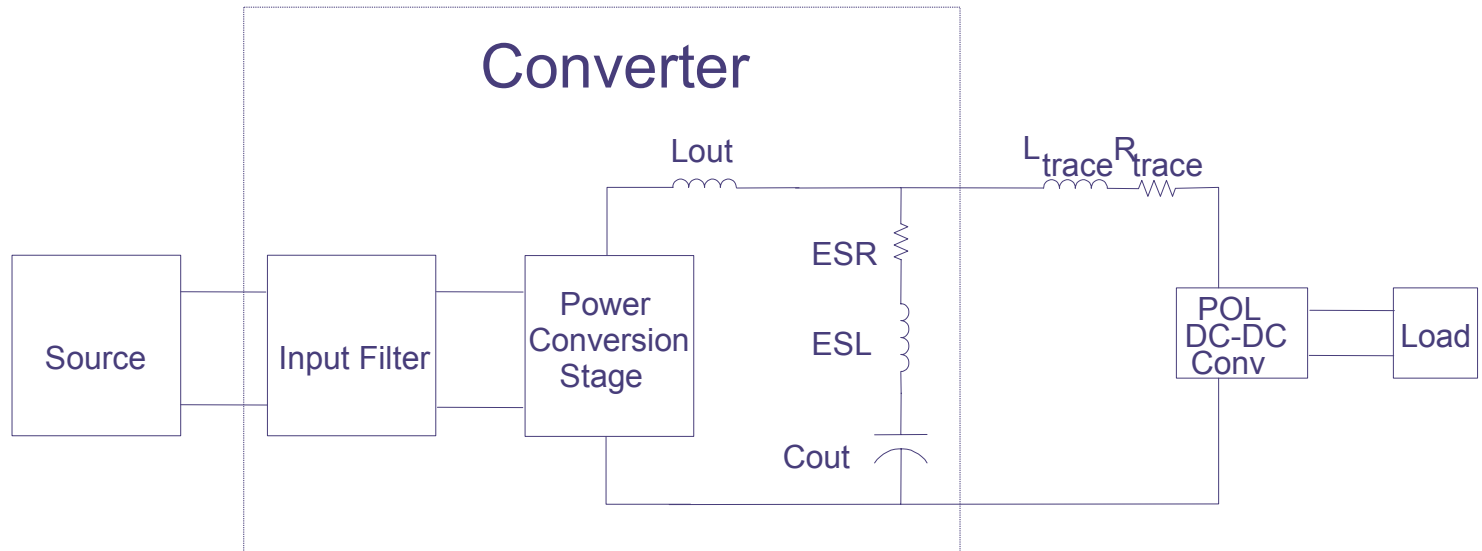

Advantages:

- Close coupling between converter and load
- Mitigates effects of parasitics
- POL converter can be small and high efficiency

Point-of-Load Conversion (2)

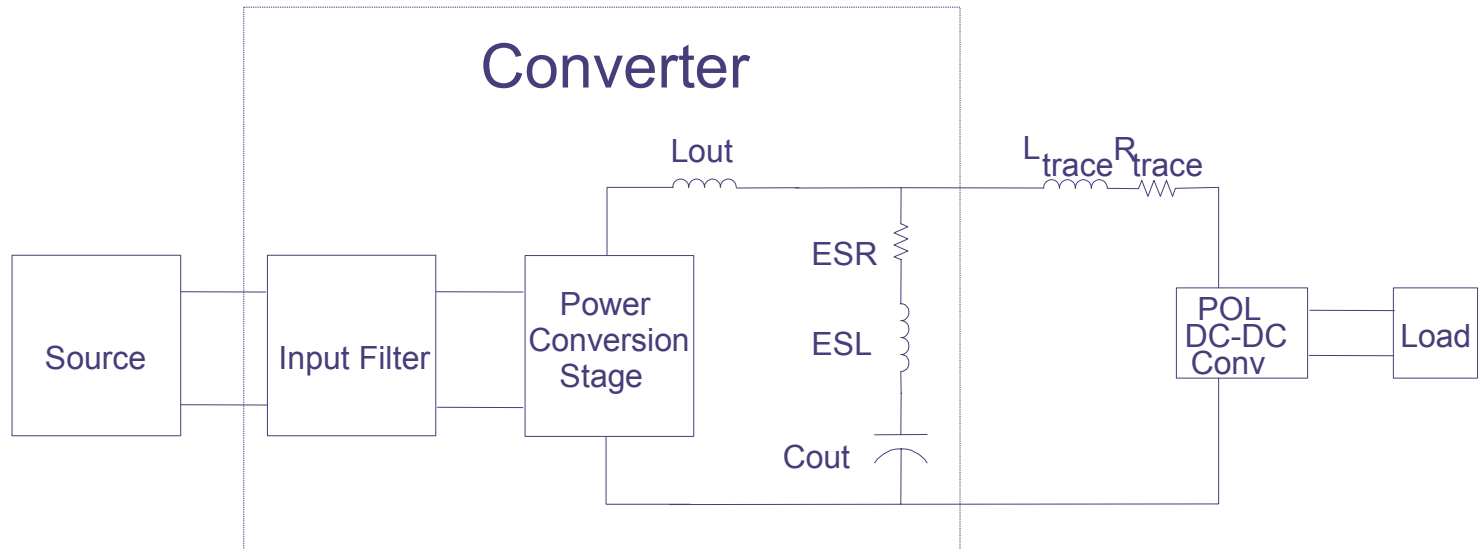

Disadvantages:

- Reduces system efficiency
- Has its own control loop and transient response issues
- Adds cost
- Adds additional component's and complexity

Single Filter, Point-of-Load Capacitance

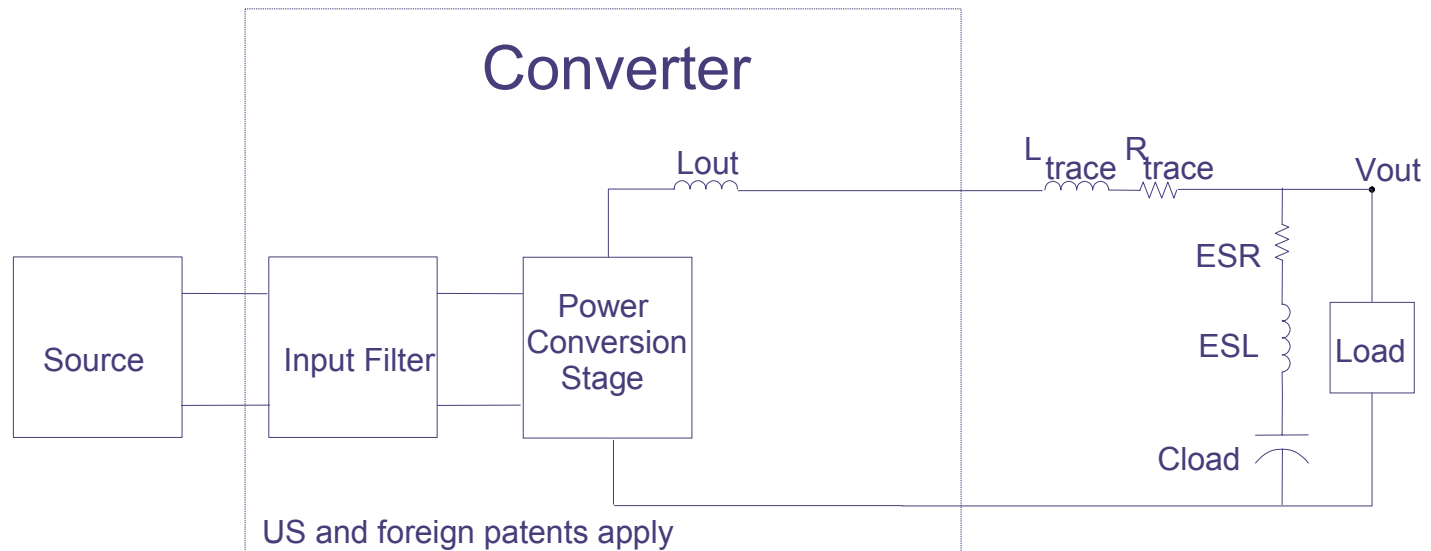

Advantages:

- Parasitic L and R are not only mitigated but consolidated and appear effectively as part of L_{out}
- Converter can be located remotely from load, freeing up real estate around load
- Cost effective
- Parts count kept to a minimum

Single Filter, Point-of-Load Capacitance(2)

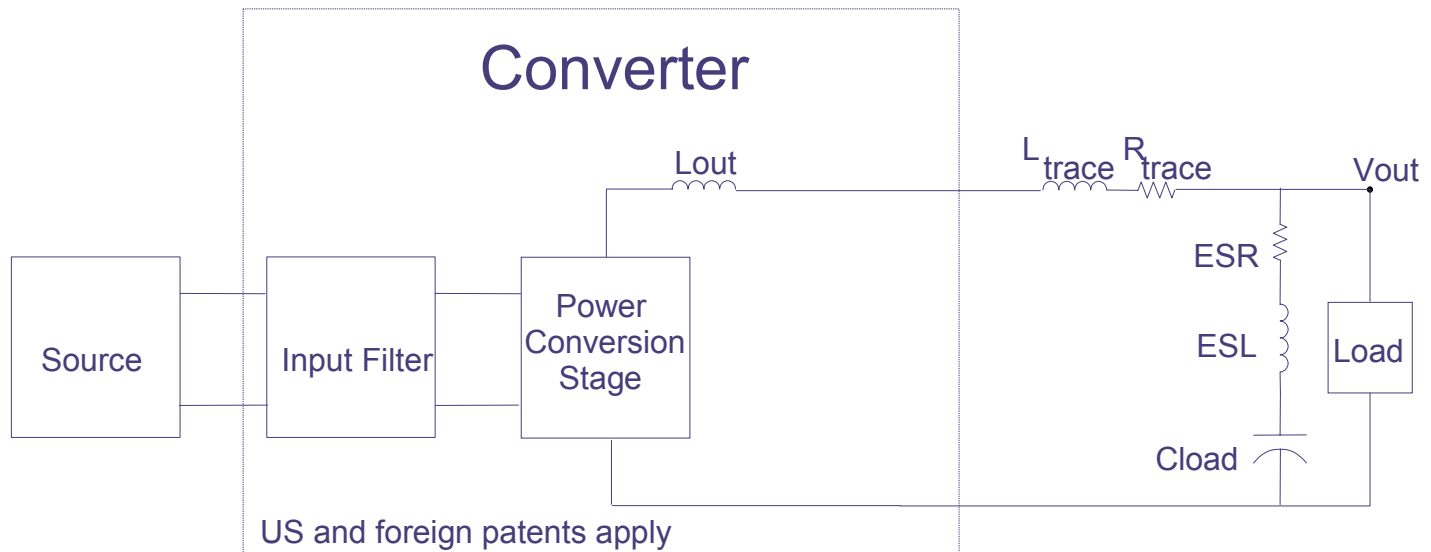

Disadvantages:

- Requires unique converter
- Doesn't eliminate transient effects due to ESR and ESL

Output Filter Design Considerations

Factors To Consider When Choosing Output Capacitors:

- **Ceramic:** Low ESR, low ESL, low capacitance per unit volume, low cost, loses capacitance as higher voltages are applied
- **Electrolytic:** High ESR, interconnect used creates high ESL, high capacitance per unit volume, moderate reliability, must make sure RMS currents do not exceed specifications
- **Film:** Low ESR, very low ESL, high voltage tolerance, low capacitance per unit volume
- **Tantalum:** Very low ESR, very low ESL, very high capacitance per unit volume, low voltage tolerance, low reliability, must make sure RMS currents are within specification, catastrophic failure mechanisms

Minimizing Trace R and L

Trace Resistance

- Use high grade copper and wide traces for +OUT and -OUT to load
- Minimize the distance between converter and load
- Minimize the number of connectors used between converter and load

Trace Inductance

- Keep the current loop (path from +OUT to load to -OUT) as small as possible
- Use twisted pair if wires are used in connecting converter to load
- Run + and - traces in separate planes on top of each other if PCB traces are used in connecting converter to load
- Run traces and/or wires such that they are routed away from magnetic fields and components

Choosing The Right Power Converter

Things To Consider When Evaluating a Converter

- Is the stated performance acceptable for my application?
- Do the stated test conditions of the converter match or exceed my load requirements?
- Is the converter capable of handling my dynamic load requirements?
- What additional components are necessary to meet my transient requirements?
- What size is the converter? Where will I need to mount the converter with respect to the load?
- What parasitics will I introduce by mounting the converter in a certain location? What tradeoffs do I sacrifice between real estate and parasitics?
- How will these parasitics affect the converter's performance?
- How will these parasitics affect the transient response?
- What solution will maximize performance, quality and reliability of the overall product?

Concluding Message...

One Size Does Not Fit All...

- Each application is unique
- Maximizing transient response requires customizing the power solution for specific loads
- Be sure to properly characterize the transient requirements of your load
- There are plenty of options and tradeoffs involved in designing to optimize transient response